



This is a digital copy of a book that was preserved for generations on library shelves before it was carefully scanned by Google as part of a project to make the world's books discoverable online.

It has survived long enough for the copyright to expire and the book to enter the public domain. A public domain book is one that was never subject to copyright or whose legal copyright term has expired. Whether a book is in the public domain may vary country to country. Public domain books are our gateways to the past, representing a wealth of history, culture and knowledge that's often difficult to discover.

Marks, notations and other marginalia present in the original volume will appear in this file - a reminder of this book's long journey from the publisher to a library and finally to you.

Usage guidelines

Google is proud to partner with libraries to digitize public domain materials and make them widely accessible. Public domain books belong to the public and we are merely their custodians. Nevertheless, this work is expensive, so in order to keep providing this resource, we have taken steps to prevent abuse by commercial parties, including placing technical restrictions on automated querying.

We also ask that you:

- + *Make non-commercial use of the files* We designed Google Book Search for use by individuals, and we request that you use these files for personal, non-commercial purposes.
- + *Refrain from automated querying* Do not send automated queries of any sort to Google's system: If you are conducting research on machine translation, optical character recognition or other areas where access to a large amount of text is helpful, please contact us. We encourage the use of public domain materials for these purposes and may be able to help.
- + *Maintain attribution* The Google "watermark" you see on each file is essential for informing people about this project and helping them find additional materials through Google Book Search. Please do not remove it.
- + *Keep it legal* Whatever your use, remember that you are responsible for ensuring that what you are doing is legal. Do not assume that just because we believe a book is in the public domain for users in the United States, that the work is also in the public domain for users in other countries. Whether a book is still in copyright varies from country to country, and we can't offer guidance on whether any specific use of any specific book is allowed. Please do not assume that a book's appearance in Google Book Search means it can be used in any manner anywhere in the world. Copyright infringement liability can be quite severe.

About Google Book Search

Google's mission is to organize the world's information and to make it universally accessible and useful. Google Book Search helps readers discover the world's books while helping authors and publishers reach new audiences. You can search through the full text of this book on the web at <http://books.google.com/>

A 772,180

PROPERTY OF
*University of
Michigan
Libraries*

1817

ARTES SCIENTIA VERIT



R. L. Shepherd
Assistant Editor
ELECTRICAL WORLD

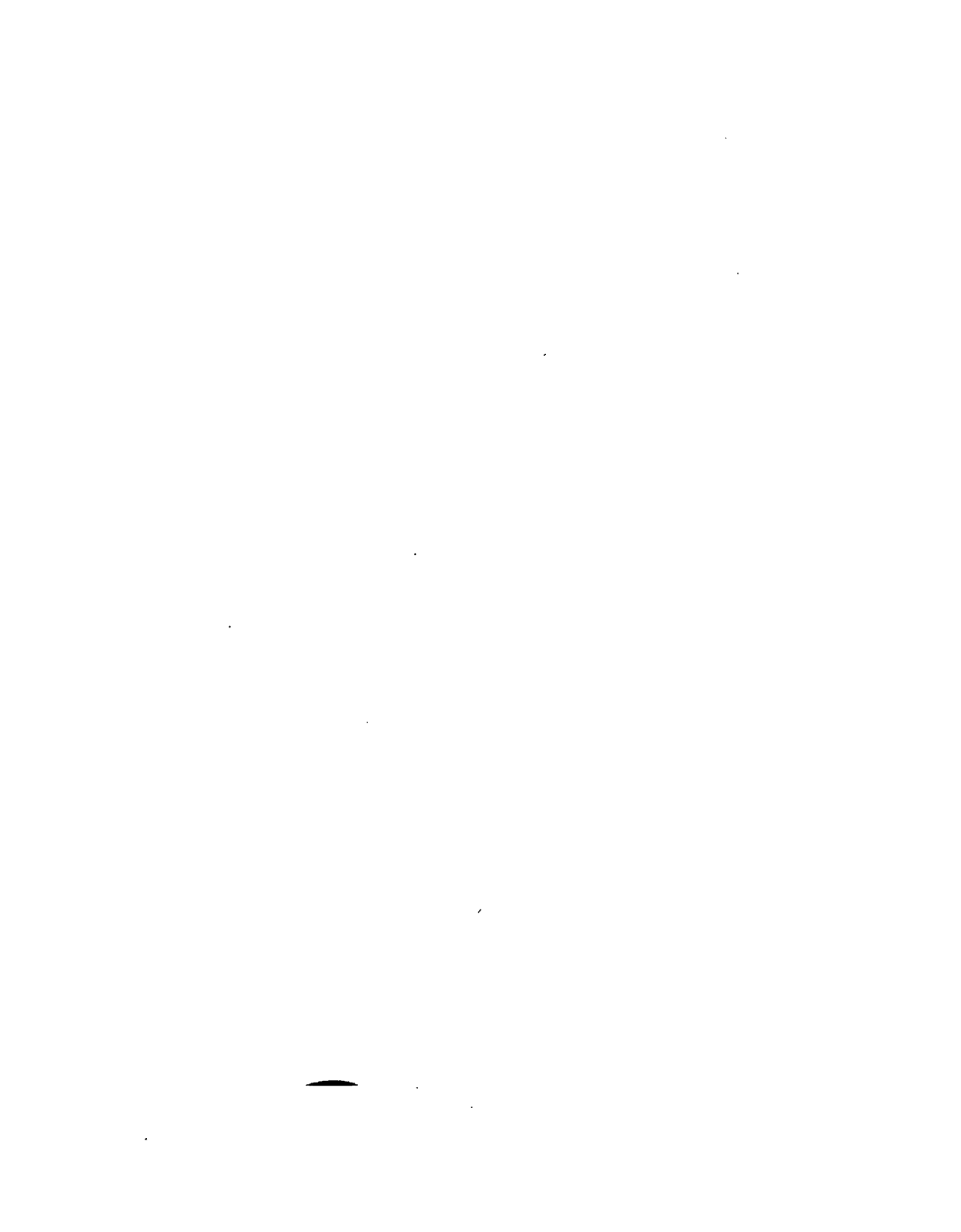

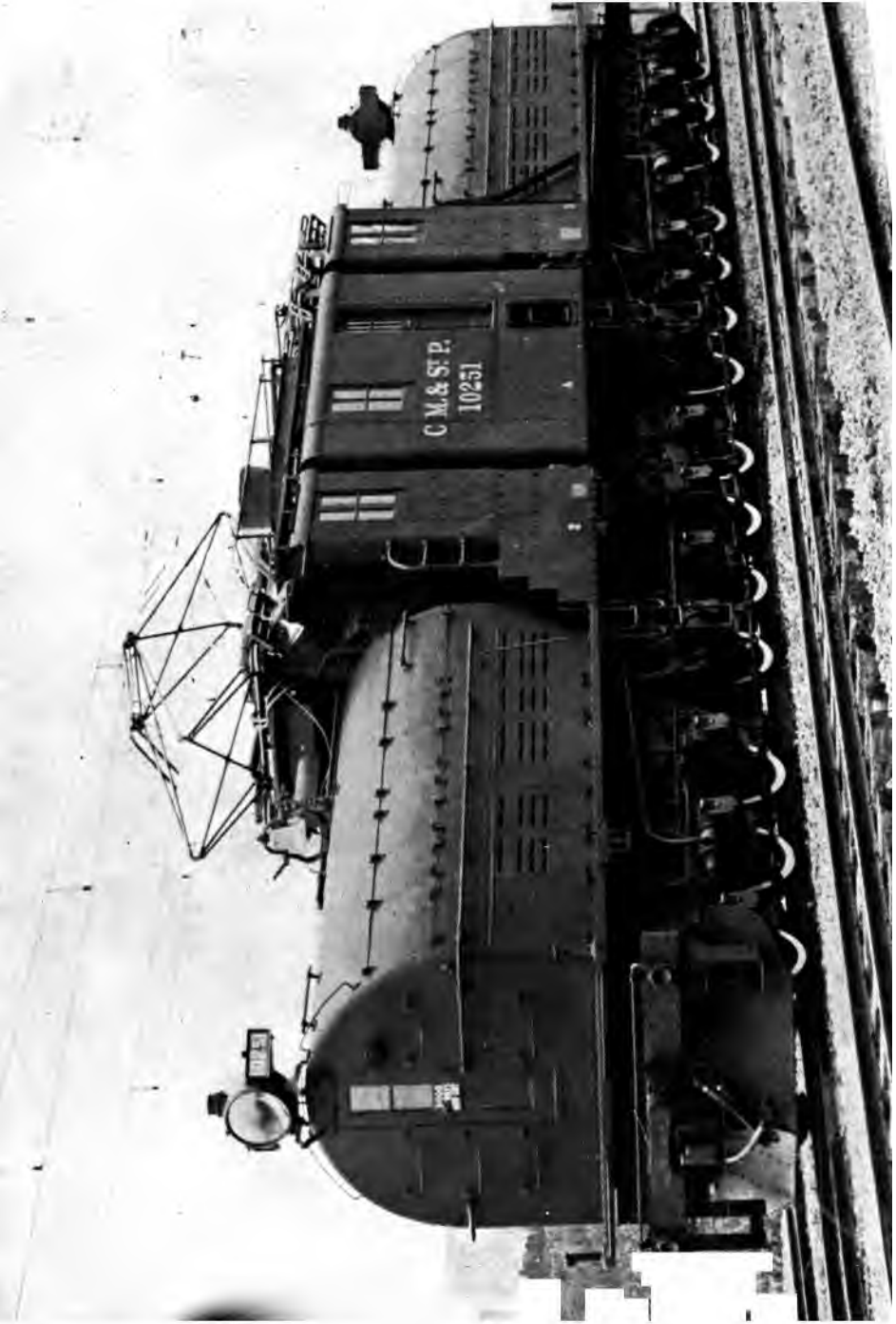

electric equipment is 11 inches in diameter and has a one-hour rating weight of 100 lbs. The diameter of the driving wheels is 22 inches and the total weight of the motor is 14 inches. The diameter of the driving wheels is 22 inches and the total weight of the motor is 14 inches. The diameter of the driving wheels is 22 inches and the total weight of the motor is 14 inches. The diameter of the driving wheels is 22 inches and the total weight of the motor is 14 inches.

This type of locomotive is operated in the same manner as the other types of locomotives. The diameter of the driving wheels is 22 inches and the total weight of the motor is 14 inches. The diameter of the driving wheels is 22 inches and the total weight of the motor is 14 inches.

The diameter of the driving wheels is 22 inches and the total weight of the motor is 14 inches. The diameter of the driving wheels is 22 inches and the total weight of the motor is 14 inches.

THE 3000-VOLT DIRECT-CURRENT LOCOMOTIVE OF THE CHICAGO,
MILWAUKEE & ST. PAUL RAILWAY.

This type of locomotive was placed in operation in 1919 for passenger service on the Othello-Seattle-Tacoma electric zone of the railway, and is of the bipolar gearless type, with the motor armatures mounted directly on the driving axles. The locomotives weigh 265 tons, have twelve driving and two guiding axles, and are designed for handling in normal service a 12-car train weighing 960 tons trailing against a grade of two per cent. at 25 miles per hour. The total length of the locomotive (inside knuckles) is 76 feet, the total wheel base is 67 feet, and the diameter of the driving wheels is 44 inches. Each of the 12 motors has a one-hour rating of 270 h.p.; the total weight of the electrical equipment is 117 tons.

Rev. 1911, 50, 10.

1250 2/25/27

ELECTRIC TRACTION AND TRANSMISSION ENGINEERING

BY

SAMUEL SHELDON, A.M., Ph.D., D.Sc.

**PROFESSOR OF PHYSICS AND ELECTRICAL ENGINEERING AT THE POLYTECHNIC INSTITUTE
OF BROOKLYN AND PAST-PRESIDENT OF THE AMERICAN
INSTITUTE OF ELECTRICAL ENGINEERS**

AND

ERICH HAUSMANN, E.E., Sc.D.

**PROFESSOR OF PHYSICS AT THE POLYTECHNIC INSTITUTE OF BROOKLYN, AND FELLOW
OF THE AMERICAN INSTITUTE OF ELECTRICAL ENGINEERS**

SECOND EDITION, REVISED



127 Illustrations

NEW YORK

D. VAN NOSTRAND COMPANY

EIGHT WARREN STREET

LONDON

CROSBY LOCKWOOD & SON

7 STATIONERS' HALL COURT, LUDGATE HILL

1920

Transportation
Library

TF
855
.554
1920

Copyright, 1911 and 1920, by
D. VAN NOSTRAND COMPANY

**OTHER WORKS
BY THE SAME AUTHORS**

**DYNAMO ELECTRIC MACHINERY
ITS CONSTRUCTION, DESIGN AND
OPERATION**

**A consolidation of the authors' former volumes.
"Direct Current Machines" and "Alternating
Current Machines."**

About 500 Pages. Illustrated. In Press

**PHYSICAL LABORATORY
EXPERIMENTS**

for Engineering Students

**PART I, MECHANICS, SOUND, HEAT
AND LIGHT**

134 Pages. 40 Illustrations. Postpaid, \$1.25

TELEGRAPH ENGINEERING

By PROFESSOR HAUSMANN

416 Pages. 192 Illustrations. Postpaid, \$3.00

Transport.

This book is sent for Review by the
Publisher who will appreciate two marked
copies of the issue containing the notice.

PRICE $\$3.00$ NET

D. VAN NOSTRAND COMPANY

8 Warren Street - - - New York

on its
urs in
was
ered
lition
elf in
that
truc-
prep-
esent

*Polytechnic Institute, Brooklyn, N. Y.,
February 1, 1920.*

7X66

PREFACE TO FIRST EDITION.

THE ultimate purpose of nearly all the professional efforts of an engineer is the attainment of efficiency in the utilization of labor, capital, and energy. To attain the highest efficiency in the construction and the subsequent operation of a complete installation requires a knowledge of the facts and a familiarity with the laws pertaining to these three factors. Decisions as to the selection of the type and the dimensions of an element, often attributed to the exercise of good judgment, are generally the specific results of the correct application of laws to all pertinent facts.

The number of facts to be considered in determining the final elements of a complete electric traction system is enormous. As a consequence students and young engineers become bewildered and are unable to discriminate as to the pertinency or necessity of specific details. To meet this condition the present text has been prepared, it being believed that no other single published book meets it.

The book attempts to present a perspective view of the design of a complete railway installation, from the cars to the power-station, to indicate the nature and sequence of the various entailed problems, and to suggest or illustrate methods for their solution.

In preparing the text the determination of what to omit has involved nearly as much effort as of what to include.

A descriptive treatment of specific forms of structures has been avoided. On the other hand, a number of numerical illustrations of the calculation of economic magnitudes has been given. Again, the inevitable future extensive use of hyperbolic functions has claimed for them a brief but comprehensive exposition and their utility is demonstrated in connection with calculations relating to electric-wave propagation.

Appreciation is hereby expressed of the services of Mr. G. I. Rhodes in making helpful suggestions and in reading the proofs of the sections on economic determinations.

POLYTECHNIC INSTITUTE, BROOKLYN, N. Y.
May 1, 1911.

CONTENTS.

CHAPTER I.

DETERMINATION OF THE NUMBER AND SIZE OF CARS FOR AN URBAN ROAD.

ART.	PAGE
1. The Engineer's Problem	I
2. Types of Service	I
3. Length of Track	2
4. Receipts	4
5. Number of Cars	4
6. Size of Cars	8
7. Trains	12
Problems	14

CHAPTER II.

TRACTIVE EFFORT REQUIRED FOR CAR PROPULSION.

8. Train Resistance	15
9. Grades	19
10. Curves	20
11. Acceleration	22
12. Braking	23
Problems	25

CHAPTER III.

TYPES AND PERFORMANCE CURVES OF MOTORS.

13. Traction Motors	26
14. Direct-current Motors	27
15. Alternating-current Motors	28
16. Methods of Drive	41
17. Motor Curves	44
Problems	49

CHAPTER IV.

SPEED CURVES.

ART.	PAGE
18. Motor Limitations	50
19. Motor Capacity	51
20. Speed	51
21. Typical Speed Curves	52
22. Data for Plotting Speed Curves	53
23. Plotting Speed Curves	56
24. Numerical Example	59
25. Distance Curves	66
26. Speed Curve Plotting with Grades and Curves	67
Problems	73

CHAPTER V.

RAILWAY MOTOR CONTROL.

27. Direct-current Control	74
28. Rheostatic Method	74
29. Series-parallel Method	75
30. Starting Resistances	78
31. Numerical Example	87
32. Field Control	89
33. Alternating-current Control	90
34. Compensators	93
35. Induction Motor Control	96
36. Controllers	103
Problems	110

CHAPTER VI.

ENERGY CONSUMPTION.

37. Current Curves	111
38. Average and Effective Currents	112
39. Numerical Example	113
40. Effective Motor Current for a Trip	116
41. Voltage Curve	118
42. Motor Heating	118
43. Energy for Direct-current Propulsion	120
44. Energy for Alternating-current Propulsion	121

CONTENTS.

xi

ART.	PAGE
45. Effect of Operating Conditions on Energy Consumption.....	124
46. Gear Ratio.....	130
Problems.....	132

CHAPTER VII.

THE DISTRIBUTING SYSTEM.

47. Classification of Conductors.....	133
48. Contact Conductors.....	134
49. Branches.....	139
50. Collecting Devices.....	140
51. Supplementary Conductors.....	142
52. Graphic Time-table.....	147
53. Feeders.....	151
54. Track Rails.....	155
55. Negative Track Feeders.....	157
56. Electrolytic Surveys.....	161
57. Alternating-current Distribution.....	164
Problems.....	164

CHAPTER VIII.

SUBSTATIONS.

58. Types of Substations.....	166
59. Direct Currents Received and Delivered.....	166
60. Alternating Currents Received and Delivered.....	168
61. Alternating Currents Received and Direct Currents Delivered...	169
62. Location of Substations.....	175
63. Numerical Illustration.....	186
64. Auxiliary Storage Batteries.....	188
65. Arrangement of Apparatus.....	189
66. Portable Substations.....	193
Problems.....	197

CHAPTER IX.

TRANSMISSION LINES.

67. Location of the Transmission Line.....	199
68. Number of Phases.....	201
69. Frequency.....	203
70. Economic Voltage.....	205
71. Numerical Illustration.....	211

ART.	PAGE
72. Separation of Conductors	213
73. Resistance of Conductors	220
74. Line Inductance	222
75. Hyperbolic Functions.....	224
76. Line Capacity	230
77. Equations of Wave Propagation along Wires.....	235
78. Attenuation and Wave-length Coefficients.....	238
79. Current and Voltage Distribution on Lines.....	240
80. Regulation.....	243
81. Numerical Illustration	244
82. Corona Loss.....	247
83. Lightning.....	251
84. Protection from Lightning	254
Problems.....	258

CHAPTER X.

POWER STATIONS.

85. Station Load Curves	259
86. Selection of Generators	261
87. Types of Prime Movers	263
88. Power Station Costs	264

Steam Stations.

89. Engines and Turbines	265
90. Condensers.....	267
91. Boilers	270
92. Feed-water Heaters.....	272
93. Chimneys or Stacks.....	272
94. Buildings	274
95. Arrangement of Apparatus	275
96. Cost of Steam Stations	280
97. Operating Expenses	280

Hydraulic Stations.

98. Turbines	281
99. Water-power Development	288
100. Cost of Development.....	293
101. Depreciation and Obsolescence	297
102. Relative Operating Expenses	299
103. Costs per Kilowatt-hour.....	299
Problems	301

ELECTRIC TRACTION AND TRANSMISSION ENGINEERING.

CHAPTER I.

DETERMINATION OF THE NUMBER AND SIZE OF CARS FOR AN URBAN ROAD.

1. The Engineer's Problem. — The problem of the electric railway engineer is the determination of the car equipment required to yield a proposed service, the characteristics of the low-potential distribution system, the location and capacity of the substation equipment, the characteristics of the high-tension transmission line, and finally the capacity of the main generating station. His report should include cost estimates of the various items of the electric railway system, probable operating expenses and approximate gross income on the investment.

2. Types of Service. — The object of a railway is the transportation of passengers or freight between any points on the road in accordance with a schedule which is prepared to accommodate the traffic most economically and to lead to a sufficient income on the original investment to the operating company. The probable location of a proposed electric railway is governed by purely local conditions, such as density of population, future growth of the community, and topography of the land. An approxi-

mate estimate of the length of a proposed railway and its subsequent income, as well as the determination of the number and size of the cars or trains, may be obtained from government reports and other statistical sources.

Electric railway undertakings are of three kinds, — new roads, extensions to existing railways, and electrifications of present steam railroads. Of these, the former will first be considered. A new electric railway undertaking may relate to an urban, suburban, or interurban installation. Frequently a single system will include all of these types of service.

3. Length of Track. — For a new urban street railway the economically feasible length of road will depend largely upon the population. Thus, curve 1 of Fig. 1 shows the number of miles of track per 1000 of population for various population centers. This curve represents the data of the following table showing the relation of trackage and traffic to population in groups of urban centers; it is taken from the Census Report on Electric Railways for 1902. The figures refer to single track, and for a double-track road the length of track is twice the length of the road.

	All centers over 500,000 population.	All centers between 100,000 and 500,000 population.	Twenty-nine selected centers between 25,000 and 100,000 population.	Forty-six selected centers of less than 25,000 population.
Total population served.....	10,274,470	5,380,647	1,258,615	718,254
Number of miles of track.....	4,998.89	3,559.82	951.93	485.95
Miles of track per 1000 of population	.49	.66	.76	.68
Number of passen- gers.....	2,456,542,270	994,327,853	135,842,312	49,179,495
Number of rides per inhabitant...	239.1	184.7	107.9	68.5

The present population is, however, not the value to be considered in determining the *track factor*, τ , from this curve, but instead the population at some future time, this time depending upon the probable duration of the

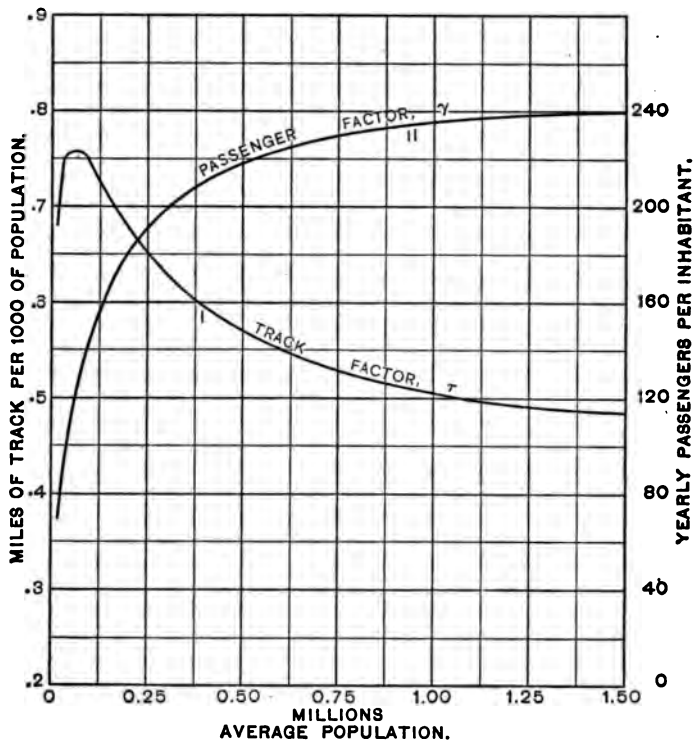

Fig. 1.

period of construction, the depreciation, and later prospective developments in electric traction. The population, N , at some future time may be estimated from the past growth of the community. Thus, a curve of population for the last one hundred years might be drawn and

extended, or a percentage increase of population may be assumed. A population value corresponding to a time ten years later offers a reasonable working basis. Then the number of miles of track, L , to be installed can be expressed as

$$L = \frac{N\tau}{1000} \text{ miles.}$$

4. Receipts.— In the foregoing table is also given the annual number of rides per inhabitant for various population centers, the data showing that passenger traffic is comparatively greater in the larger cities. The riding habit of people increases from year to year as the community grows, as its business, family and social life becomes more complex, and as its facilities for intercommunication improve. Curve 2, Fig. 1, shows the number of yearly passengers per inhabitant, or what may be termed the *passenger factor*, γ . Then the number of passengers per year can be written as

$$\text{Yearly passengers} = N\gamma.$$

The annual receipts, in dollars, R , of a traction company are evidently the product of the total yearly passengers into the fare, f , in dollars, or

$$R = N\gamma f \text{ dollars.}$$

In this country the usual urban fare prior to the war was five cents regardless of the distance traveled. For inter-urban roads the fare depends upon the distance traveled, varying from one to three cents per mile.

5. Number of Cars.— The determination of the number of cars to install may be made by the aid of tables which show the income and operating expenses per car

NUMBER AND SIZE OF CARS FOR URBAN ROAD. 5

mile of a number of electric railways. The following table compiled by H. M. Beardsley gives such data for some electric railways in New York State for 1905. Herefrom the average income per car mile is 21.56 cents.

Company.	Income from operation.	Income per car mile.	Total expense per car mile.
		Cents.	Cents.
Albany & Hudson.....	\$200,671.65	28.50	24.30
United Traction Co. of Albany....	1,714,848.82	22.35	15.35
Auburn and Syracuse Co.....	268,507.78	25.12	16.24
Binghamton Ry. Co.....	258,819.85	20.14	11.23
International Tr. Co. of Buffalo...	3,694,339.01	25.16	14.90
Rochester & Eastern.....	212,668.51	27.88	21.36
Cortland Traction Co.....	49,139.86	22.95	16.06
E. W., L. & R.R. Co., Elmira.....	192,921.47	16.06	11.61
City Ry., L. & R. Co., Fishkill....	41,474.56	24.17	16.34
Dunkirk & Fredonia.....	44,457.88	26.92	22.57
Hudson Valley Ry. Co., Glens Falls.	499,148.09	25.89	18.13
Hornell Elec. Ry., Hornellsville...	16,919.70	9.30	9.06
Ithaca St. Ry. Co., Ithaca.....	91,817.90	23.21	17.87
King. Consol. R.R. Co., Kingston..	123,632.92	23.08	14.57
Orange County Trac. Co., New- burgh.....	119,270.85	20.04	15.39
Ogdensburg St. Ry. Co.....	27,240.09	9.78	7.86
I. C. & R. S. Ry. Co., Oneonta....	103,862.05	15.97	13.82

The following table presents information compiled by G. H. Davis and furnished by sixteen electric railway companies which represent both geographically and politically nearly all sections of the United States and all conditions of operation. The values given are for the year 1910; the average passenger earnings per car mile being 27.31 cents.

The growth of traction earnings in the larger American cities, together with the corresponding operating expenses on a car mileage basis are shown in Fig. 2, which was prepared by B. J. Arnold. It will be noted, for instance, that in Brooklyn the earnings per car mile (average for street

Company.	Population served within corporate limits.	Total population served.	Length of single track in miles.	Car miles operated annually.	Passenger earnings per car mile in cents.	Average revenue per passenger, including transfer, in cents.	Length of longest ride possible for one fare in miles.
1	485.2	53,362,500	27.80	* 3.1	20.0
2	533,905	1,018,463	585.0	37,537,433	28.77	* 4.34	14.4
3	465,786	208.2	* 3.3	13.5
4	373,740	403,740	136.0	13,812,813	27.42	3.12	12.1
5	347,469	512,886	101.7	* 15,377,000	31.50	3.62	14.6
6	516,152	516,152	306.6	24,229,010	30.75	3.89	17.7
7	233,650	234,650	139.7	9,346,183	28.86	* 3.3	12.6
8	131,105	151,105	110.4	6,895,421	26.14	4.09	16.1
9	129,867	216,867	86.8	4,068,502	28.70	4.10	8.3
10	155,000	185,000	186.0	9,538,867	23.84	4.09	18.0
11	88,926	129.4	26.14	4.90	14.0
12	51,521	60,521	58.0	4.94	7.8
13	132,685	140,000	133.0	6,194,583	26.32	4.08	13.6
14	36,346	71,346	41.6	2,045,703	23.29	* 4.2	9.5
15	1,549,008	1,993,400	627.6	70,943,404	25.34	4.15	19.5
16	46,000	46,500	33.0	1,790,722	27.42	4.07	8.8

* Estimated.

and elevated railway service) increased from 24 cents in 1902 to 29 cents in 1906 and then decreased to 26.8 cents in 1910.

The total number of annual car miles to be operated is equal to the annual receipts divided by the annual income per car mile R_{cm} ; this result, when divided by 365 days and the daily number of hours of operation, h , gives the number of car miles to be operated per hour. If this be divided by the schedule speed, V , in miles per hour including stops, there results the number of cars required for the service. The schedule speed is limited by city ordinance in many cities to 12 miles per hour or less. The smallest number, ν , of cars required then, may be expressed as

$$\nu = \frac{R}{365 h V R_{cm}} = \frac{N \gamma f}{365 h V R_{cm}}$$

NUMBER AND SIZE OF CARS FOR URBAN ROAD. 7

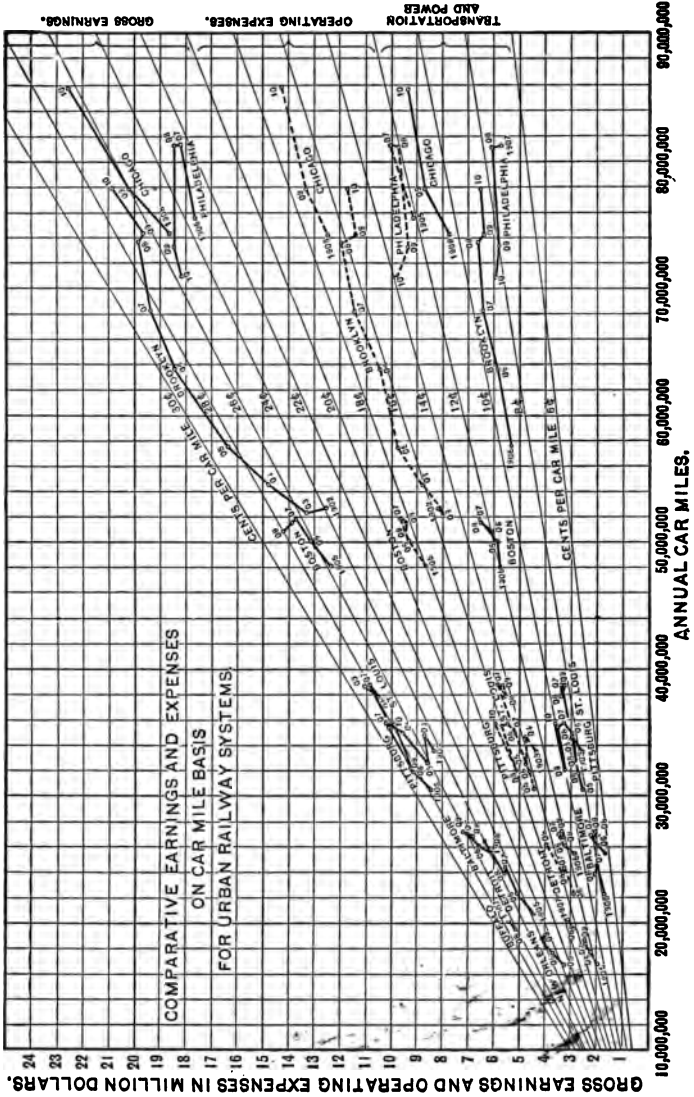

Fig. 2.

6. **Size of Cars.** — The number of passengers carried per year divided by 365 and the number of cars in service gives the average number of passengers conveyed by each car per day. The number of trips per day made by each car is found by multiplying the schedule speed by the number of hours the car operates daily and dividing by the length of the line. The average number of passengers per trip is therefore

$$P = \frac{N\gamma L}{365 \nu V h} = \frac{N\tau R_{cm}}{1000 f}$$

When several lines are operated in the same district or city, the second member of this equation applies to each line of track-length L miles. With a single line the last member is applicable.

The number of passengers riding in a car at different times varies widely, and it would be poor economy to employ cars or trains of such size as to permit the average number of passengers per trip, as obtained from the foregoing expression, to be seated at one time. Not all of these passengers ride the full length of the road, and again, others may stand. In a specific case information should be obtained, from records concerning similar cases, as to the average length of rides by passengers. Available data indicate that the average passenger ride, r , is from 2 miles to 4.5 miles.

The length of track divided by the average length of ride determines the number of times that the car is refilled each trip. The average number of passengers per trip divided by this number gives the passenger capacity of a car as

$$C = \frac{Pr}{L} = \frac{N\gamma r}{365 \nu V h},$$

an expression which assumes uniform traffic conditions. With due consideration for the provision of additional



Fig. 3.



Fig. 4.

seats for the accommodation of passengers during the rush hours, the seating capacity of the car is thus determined.

Climatic conditions and limitations as to the total amount of rolling stock determine the characteristics of car-body

construction as to whether it shall be open, closed, convertible, semiconvertible, double-decked, or combination open and closed. Figs. 3, 4 and 5 show the character-

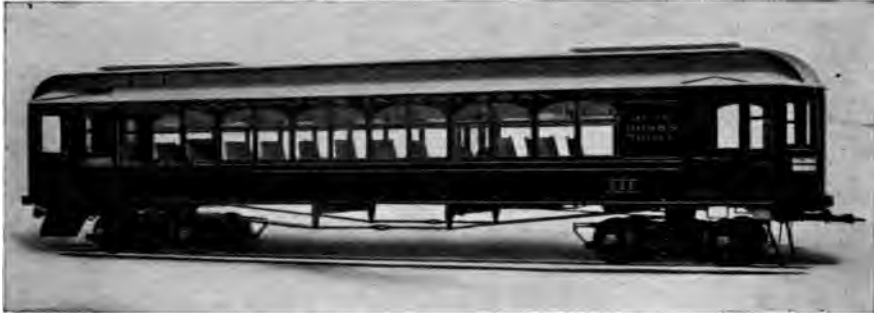

Fig. 5.

istic forms of construction of convertible, "Narragansett" open, and semiconvertible interurban cars respectively.

Fig. 6 (top) shows a pay-as-you-enter car which is being extensively adopted for congested urban traffic because it facilitates comfort, ingress and egress of passengers, and collection and conservation of fares. In non-congested traffic districts "one-man" cars, Fig. 6 (bottom), are being used, wherewith the motorman is the only attendant; naturally the cost of operation is reduced.

The arrangement of seats, as to whether they shall be transverse, longitudinal, or partly both, is dictated by the type of service to be rendered. Transverse seats are far more comfortable for seated passengers and are essential in long-haul service. Longitudinal seats greatly facilitate ingress and egress of passengers, give greater comfort to standing passengers, and as a rule permit of a greater ratio of standing to seated passengers. In urban and frequent-

NUMBER AND SIZE OF CARS FOR URBAN ROAD. II

stop service facility of ingress and egress is of paramount importance in order that a high schedule speed may be maintained. During the morning and evening rush hours the number of standing passengers frequently equals that of those seated.

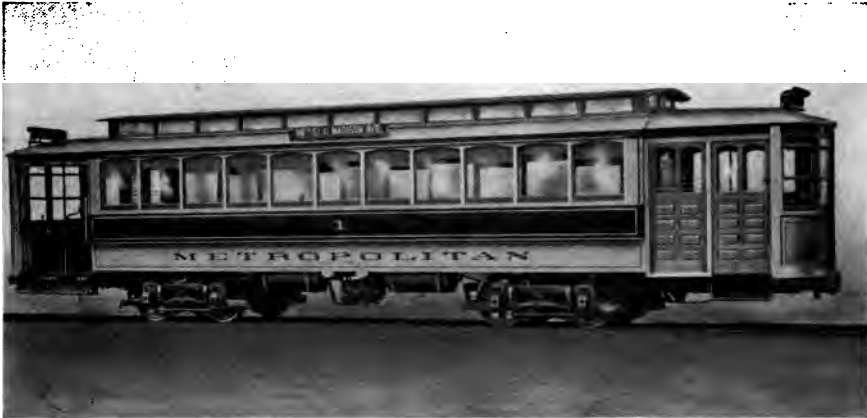

Fig. 6.

The weights of car bodies are always much greater than might be desired, but are necessitated in order to give adequate strength to withstand the rough usage of ordinary service and to give some insurance against collapse in case of collision. As will appear later, the first cost and expense of operation are dependent upon the total weight. The weight of passengers seldom reaches one-quarter the total weight. It is evidently desirable to reduce the weight of cars to a minimum consistent with adequate strength.

The total weights of closed and semiconvertible cars of recent design are usually between 90 and 130 pounds per square foot of floor area, considering the floor area as the product of the length over bumpers by the width over belt rails.

An analysis of the possible saving incident to the use of light cars in a group of street railway properties, having for 1910 gross earnings of approximately \$5,700,000, shows that of the 92.33 per cent of such earnings expended for all purposes, excluding dividends, including operating expenses 54.47 per cent, interest 24.74 per cent, taxes 7.12 per cent, depreciation 6 per cent, only 53.08 per cent is influenced by car weight or live weight transported. Of this the items particularly affected are cost of power, car and track repairs, interest and depreciation, which in the aggregate do not generally exceed 15 per cent of the gross earnings.

Having decided upon the seating capacity of the car, its size and weight may be determined from the following table. The average weight of a passenger may be taken as 140 pounds. The weights of trucks as given include the weights of motors except where starred.

7. **Trains.** — In most of the large cities in the United States the traffic is so dense that the capacity of the largest car which it is practicable to employ is inadequate to meet conditions. It is customary therefore to operate trains of two or more cars. On surface roads a motor car connected with a trailer is often used and in southern cities it becomes possible to thus separate the colored and white people by assigning the trailer to the former passengers.

In subways and on elevated roads 10-car trains are often operated. On the New York Municipal Railway each car accommodates 78 seated and 72 standing passengers, allowing 5 square feet of floor space to each standing individual. With cars of such size a number of doors should be provided so that the duration of stops will not be excessive. The cost of operation per car mile with trains is materially reduced by the use of side doors having remote-control

CAR DATA.

Type.	Length of body.	Seating capacity.	Weight of body, pounds.	Weight of trucks, pounds.
Closed cars:				
Single truck.....	16'	22	6,000	4,600*
Single truck.....	18'	24	6,575	4,825
Single truck.....	20' 8''	32	13,750	5,125
Single motor.....	28'	38	11,310	7,050
Double truck.....	30' 8''	44	26,725	14,500
Manhattan Elev.....	42'	58	22,000	15,000*
I. R. T. Co. (steel)..	44'	60	56,300	21,000*
N. Y. C. (steel).....	50'	70	85,100	21,000*
Open cars:				
8-bench.....	15' 8''	32	6,375	5,150
10-bench.....	21'	50	13,340	5,925
12-bench.....	30' 2''	60	15,250	11,250
14-bench.....	30' 2''	70	20,300	7,550
Semiconvertible cars:				
Single truck.....	18'	24	6,640	4,900
Single truck.....	20' 8''	32	10,240	5,100
Double truck.....	28'	40	15,120	10,450
Double truck.....	30' 8''	44	19,500	10,800

automatic door-opening devices, which practice reduces the number of employees to one attendant per car.

On suburban sections of electric railways the schedule speed is most frequently from 15 to 20 miles per hour and on interurban sections from 25 to 35 miles per hour. The highest schedule speed at present for limited interurban service is 55 miles per hour on a 36-mile run. At high speeds the energy consumption per mile per ton of car weight is much greater for a single car than for a train of several cars, and consequently economical interurban operation dictates the employment of trains of several units instead of single cars. It is interesting to note that the traffic on an interurban railway is furnished principally by the inhabitants of the towns, the rural districts supplying only from about 20 to 30% of the total traffic.

PROBLEMS.

1. How many cars, accommodating at a maximum 80 passengers each, should be used for a proposed electric railway for a city of the size indicated below? The schedule speed is specified at 10 miles per hour over three parallel lines of equal length, the period of operation to extend over the entire day. Take 4 miles as the average passenger ride, and assume the traffic at rush-hours to be five times the average traffic and to endure for about two hours morning and evening. The past growth of this city is indicated below:

1850.....	2,000 inhabitants
1860.....	4,000 "
1870.....	8,000 "
1880.....	17,000 "
1890.....	42,000 "
1900.....	90,000 "
1910.....	200,000 "
1920.....	350,000 "

2. Plot a curve showing the relation which should exist between the population of the city just referred to in former years, and the number of cars necessary at those times.

CHAPTER II.

TRACTIVE EFFORT REQUIRED FOR CAR PROPULSION.

8. Train Resistance. — The determination of motor capacity for a proposed service involves a knowledge of the tractive effort to be exerted to produce the specified or assumed acceleration against the resistances offered by windage, friction, grades and curves, and also information about the performance of various sized motors such as is usually embodied in motor characteristic curves supplied by the manufacturers. The *tractive effort*, or force exerted at the rim of the car wheels, required to propel a car at constant speed on a straight level track is only that necessary to neutralize at that speed the resistance offered to car movement by bearing friction, rolling friction and flange friction on the track, and wind pressure; these resistances are considered under the single term *train resistance*. Many empirical formulæ based upon experimental data have been proposed for use in estimating train resistance. A consideration of the various components of train resistance mentioned above will lead to the formulation of a fairly reliable expression therefor.

Bearing friction, resulting from the sliding of the surfaces of the axles over those of the journals, follows the ordinary laws of sliding friction. It depends upon the pressure between the surfaces, and increases slightly with speed. Rolling friction is due to deformation of the rails and wheel rims where they come in contact, and to un-

evennesses in the surface of the track. The energy consumed in overcoming rolling friction is theoretically proportional to the weight on the track and to the distance covered. The force required to overcome it should therefore be constant. It is, however, generally assumed to increase slightly with the velocity of the train. Experimental data thus far obtained warrant the following expression for the tractive effort necessary to overcome bearing and rolling friction:

$$R' = k + KV,$$

where R' is expressed in pounds tractive effort per ton of car weight, V is the speed in miles per hour, and k and K are constants. The value of k , since it depends upon the weight concentrated on the bearings, may be expressed in terms of train weight, W , in tons, and the expression

$$k = \frac{50}{\sqrt{W}}$$

gives results agreeing well with experimental values, the minimum value of k being limited to 3.5. Values of K obtained experimentally vary from 0.03 to 0.07 depending upon track conditions and type of equipment, the lower values being the more representative. For light equipment and poor conditions of track the use of higher values is desirable. The resulting expression for bearing and rolling friction may then be written simply as

$$R' = \frac{50}{\sqrt{W}} + \frac{V}{25} \text{ pounds per ton.}$$

The principal component of train resistance at high speeds is the wind pressure on the moving car. Wind pressure varies approximately as the square of the car

TRACTIVE EFFORT REQUIRED FOR CAR PROPULSION. 17

velocity, as shown by numerous experiments. Therefore an expression for head-end wind resistance takes the form

$$R'' = k'SV^2 \text{ pounds,}$$

where S is the car cross section in square feet and k' is a constant denoting the wind pressure per square foot at unit speed, the value of which depends upon the shape of the car end. For cars with perfectly flat ends its value would be about 0.004 and for cars of the pointed-nose design k' is as low as 0.0015, whereas for city and suburban cars of the usual types and for the modern electric locomotives a value of 0.0025 may be taken with propriety. The wind pressure thus far considered is that on the car end, but there is also air resistance at the sides of the car or cars, which effect is particularly prominent in trains of several cars. There it becomes necessary to introduce a factor which takes care of this skin friction along the surface of succeeding cars, and it is usual to add 10% of the head-end resistance as just obtained for each car following the first. Then, if n be the number of cars in the train, the tractive effort in pounds per ton of train weight is

$$R_1 = \frac{50}{\sqrt{W}} + \frac{V}{25^*} + \frac{SV^2}{400^*W} \left[1 + \frac{n-1}{10} \right] \text{ pounds per ton,}$$

a formula which combines the various expressions of the components of train resistance. Car cross sections may be taken as follows: 90 sq. ft. for 20-ton cars, 100 sq. ft. for 30-ton cars, 110 sq. ft. for 40-ton cars, and 120 sq. ft. for heavier cars.

* A. H. Armstrong uses 33 and 500 as average values of the respective constants of the second and third terms in his formula.

Fig. 7 shows by curves the dependence of train resistance of single cars upon speed and weight of car as determined by the foregoing formula.

As an illustration, determine the tractive effort per ton exerted by an electric train of one or more cars when run-

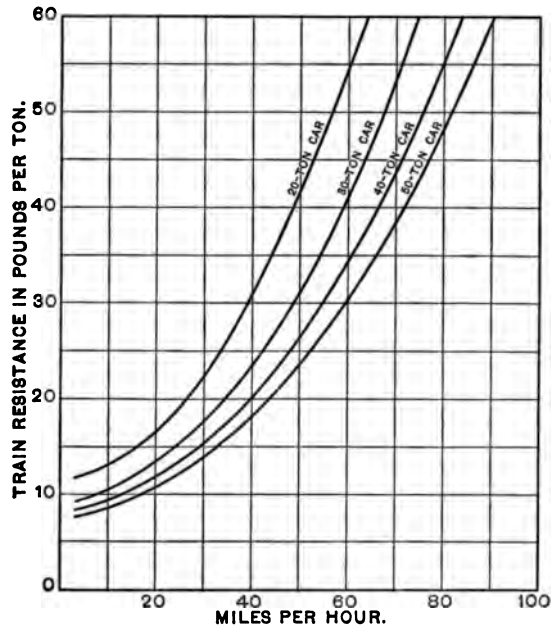

Fig. 7.

ning at 60 miles per hour on a straight level track, assuming the weight of each car to be 50 tons and the cross-sectional area as 120 square feet. The tractive effort for a single-car train is $\frac{50}{\sqrt{50}} + \frac{60}{25} + \frac{120(60)^2}{400 \times 50} = 31.1$ pounds per ton; and for a three-car train is

$$\frac{50}{\sqrt{50 \times 3}} + \frac{60}{25} + \frac{120(60)^2}{400 \times 50 \times 3} \left(1 + \frac{3 - 1}{10} \right) = 15.1$$

pounds per ton.

The formula for R_1 is not suitable for car or train speeds less than about 5 miles per hour, for tests at speeds lower than this value have shown that the train resistance per ton is greater than the formula indicates. For example, tests by D. D. Ewing on a 27-ton interurban car showed that under varying track conditions a tractive effort of from 25 to 54 pounds per ton were required to *start* the car on a straight level roadway, the average being 40. To keep this car just perceptibly moving required 22 pounds per ton, which is about double the tractive effort needed at 5 miles per hour.

The train resistance in tunnel and subway operation exceeds the value for trains run in the open because of increased windage. Various tests indicate that if the values derived from the preceding equation be increased by about 20 per cent., they will be found suitable for subway operation.

9. Grades. — If grades be encountered additional tractive effort must be exerted. If a car be on a grade of inclination α to the horizontal plane, Fig. 8, the component of its weight along the direction of motion is $W \sin \alpha$, the other component being balanced by the reaction of the rails. To maintain uniform motion up the grade a force equal and opposite to $W \sin \alpha$ must be exerted. For small values

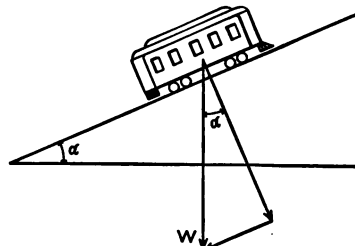

Fig. 8.

of α , such as are met with in railway work, $\sin \alpha = \tan \alpha$ approximately, whence grades may be expressed as the ratio of the vertical rise to the horizontal length of grade. It is customary, therefore, to consider that a grade of q per cent means a rise of q feet in a hundred feet. The tractive effort necessary to propel each ton of car weight up a one per cent grade is therefore $\frac{1}{100} \times 2000$, or 20 pounds, and to draw a car of W tons up a grade of q per cent with uniform speed requires

$$G = 20 qW \text{ pounds}$$

tractive effort. For a down grade G is considered negative.

For routes having numerous grades, q should be taken as the *equivalent* percentage grade. On the assumption that only half of the kinetic energy acquired by a car or train in descending a grade is utilized in ascending the next up-grade because of stops on grades, non-alternate distribution of up- and down-grades, and the necessity of braking to avoid excessive speeds; the equivalent up-grade may be expressed as

$$q = \frac{100}{L} \left(h_1 - \frac{h_2}{2} \right),$$

where h_1 and h_2 are the respective sums of all the rises on up-grades and the drops on down-grades in feet, and L is the length of the route in feet. In building a roadway, grades should be made as small as is economical, so that the cost of operation over the grades will be less than the interest on the amount necessary to reduce the grades.

10. Curves. — Curvature of track presents additional resistance to the motion of a car because of increased flange friction. To neutralize this effect a larger tractive effort must be exerted, but since curves are usually of short length, this does not present a serious factor. Indeed

track curvature may be ignored in calculations of required torque unless such curves are numerous and very sharp.

Sharp curves, such as occur with city traction systems, are generally rated by radius, but long curves are expressed in degrees, a one-degree curve being conventionally defined as one in which a chord 100 feet long will subtend an angle of one degree at the center. Thus the radius of a one-degree curve is quite accurately $\frac{360 \times 100}{2 \pi}$, or 5730 feet,

and consequently the number of degrees of curvature, c , of a curve, specified according to convention by radius R , Fig. 9, is

$$c = \frac{5730}{R} \text{ degrees.}$$

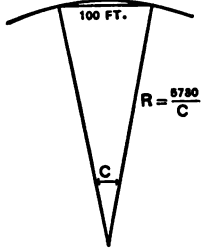

Fig. 9.

Curve resistance is usually taken as from 0.4 to 1.0 pound per ton of train weight per degree of curvature, and depends upon the speed of the train.

Prof. E. C. Schmidt gives the following formula for curve resistance as a result of tests on a 28-ton car:

$$C = 0.058 cV \text{ pounds per ton,}$$

where V is the velocity in miles per hour.

When a car moves around a curve it experiences a centrifugal force which depends in magnitude upon the speed and mass of the car, and the degree of curvature. This force tends to derail the car by rotating its center of mass outwardly around the outer rail. To neutralize this tendency the outer rail is raised above the inner rail to such an extent that the plane of the track is perpendicular to the resultant of the centrifugal and gravitational forces acting on the car.

Let m = mass of car in pounds, v = speed in feet per second, g = acceleration of gravity in ft./sec.², and R = radius of curve in feet. Then

$$\frac{mv^2}{R} = \text{horizontal centrifugal force, and}$$

$$mg = \text{vertical gravitational force.}$$

An inspection of Fig. 10 shows that the resultant of these forces will be perpendicular to the plane of the track when that plane makes an angle θ with the horizontal such that

$$\theta = \tan^{-1} \frac{v^2}{Rg}.$$

A road section devoid of curves is said to have a tangent track.

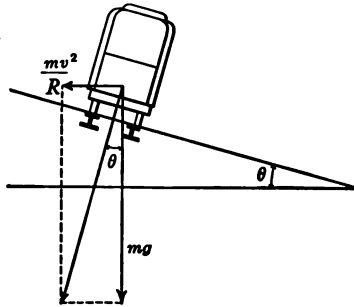

Fig. 10.

11. Acceleration.—In the foregoing paragraphs only the torque to be exerted at the rim of the car wheels for uniform speed was determined. But in railway operation a number of stops must be made to allow passengers to board or alight from the cars, or to take on or unload freight, and further, between these stops the velocity of the car must be such as to maintain the specified schedule. Thus the car must be accelerated, and later brought to rest.

To accelerate a car requires considerable tractive effort. The force in pounds acting on a body weighing w pounds which produces a change of velocity of a feet per second in one second is $f = \frac{wa}{g} = \frac{w}{32.2} a$ pounds. Representing the weight of the car in tons by W , and the rate of acceleration in miles per hour per second by A , then the tractive effort required for acceleration alone is

$$F = \frac{2000 W}{32.2} \cdot \frac{5280 A}{60 \times 60} = 91.3 WA \text{ pounds.}$$

To allow for the energy of rotation of armatures, wheels, etc., which is difficult of exact determination and which depends upon the construction of these parts, the constant 91.3 is replaced by 100. Acceleration rates of from $\frac{1}{2}$ mile to 2 miles per hour per second are usual for cars and rapid-transit trains, while lower rates apply to locomotive-hauled trains. The greater the acceleration rate of a given equipment, the higher will be the schedule speed which can be maintained thereby. Limitations are imposed upon the maximum acceleration rate attainable by considerations of comfort to passengers, permissible starting current, and slipping of wheels on the rails. Thus the total tractive effort required at any instant for the propulsion of a car or train of total weight W tons may be expressed by the complete general equation

$$T = \left\{ 50 \sqrt{W} + \frac{WV}{25} + \frac{SV^2}{400} \left[\frac{n+9}{10} \right] + 20 qW \right. \\ \left. + 0.058 V Wc \right\} + 100 WA \text{ pounds.}$$

Representing the expression in braces, which includes the effects of train resistance, grades, and curves, by T_T pounds, and rearranging, the acceleration becomes

$$A = \frac{T - T_T}{100 W}.$$

12. Braking. — The kinetic energy represented by a moving car at any instant must be dissipated in some manner if the car is to be brought to a standstill at some later time. A force must in some manner be exerted between the roadway and the car, and must be in such a direction as to oppose and retard the latter's motion. The force generally utilized is that due to static friction between

the wheel rims and the track rails where they are in contact. Two bodies with surfaces held in contact with each other by transverse pressure are capable of exerting forces upon each other along the direction of their plane of separation, which forces may be varied in magnitude from zero to such a maximum as will initiate sliding of the surfaces with respect to each other. This maximum usually bears a fairly constant ratio to the transverse force which presses the surfaces together, and is the *coefficient of friction* for the given materials of which the bodies are constituted. This coefficient for moving steel wheel rims on steel rails is, however, not constant because of the small areas in contact and the consequent enormous normal pressures, and because fresh surfaces are continually becoming effective. This variable coefficient is also called the *coefficient of adhesion*, and, while it may amount to 0.3 for clean dry rails, frequently sinks to 0.15 for wet rails, and may be subsequently raised to 0.25 by the application of sand. If the maximum *retardation*, or negative acceleration, which this coefficient 0.25 will permit, be represented by A_B , then the maximum retarding force or *braking effort*

$$F_B = 0.25 W = \frac{W}{g} A_B \text{ tons,}$$

and consequently the retardation rate

$$A_B = 0.25 g = 8.04 \frac{\text{ft.}}{\text{sec.}^2} = 5.5 \text{ miles per hour per second.}$$

To bring this frictional force into existence the kinetic energy of the car must be gradually dissipated. This is usually accomplished by pressing brake shoes upon the rims of the wheels so that the energy is consumed in attrition and heating of the shoes. The pressure on the brake

shoes is attained through levers actuated by hand, by pneumatic pressure, or by electromagnetic forces. The energy is sometimes allowed to expend itself in rotating the motor shaft against an electromagnetic counter-torque, a portion of the energy being thus returned to the line.

The coefficient of friction between brake shoes and wheel rims decreases with increase of speed, of pressure, and of duration of application. The last is doubtless occasioned by the local elevation of temperature. To use the brake-shoe friction most effectually the pressure should, therefore, be a maximum at high speed and be reduced with decreasing speed. This friction should never be so great as to cause slipping of wheels on the track, for the adhesion is thereby reduced and flat wheels may also result.

PROBLEMS.

3. Calculate the total train resistance of a New York Central locomotive weighing 220,000 pounds when it runs alone at a uniform velocity of a mile per minute. Cross section of locomotive is 120 square feet.

4. Determine the tractive effort required to enable a train consisting of 5 motor cars and 3 trailers to climb a 3.1 % grade with a uniform speed of 15 miles per hour. The weight of the trucks per car is 9 tons; the weight of motors and control equipment per motor car is $7\frac{1}{2}$ tons; and the weight of a car body is 21 tons. Each car can accommodate 80 passengers (average weight = 140 pounds).

5. If a curve having a radius of 1500 feet existed on this section of the road, how much additional tractive effort must be exerted to maintain the same velocity?

6. Calculate the total tractive effort required to accelerate a car weighing 30 tons, carrying 50 passengers, at the rate of 1.3 miles per hour per second on a tangent level track. Take 140 pounds as the average weight of a passenger. Neglect train resistance.

7. Assume a train to be running on a straight level track at 60 miles per hour and an adhesion of 0.25 to be available for making an emergency stop. Find the elapsed time and distance covered in making the stop.

8. Determine the proper elevation of the outer rail of a track for train speeds of 25 miles per hour, a curvature of 6 degrees, and a track gauge of 4 ft. $8\frac{1}{2}$ inches.

CHAPTER III.

TYPES AND PERFORMANCE CURVES OF MOTORS.

13. Traction Motors. — An electric motor suitable for traction purposes must exert the necessary torque for accelerating the car at the predetermined rate, or to propel the car up a grade, without causing excessive energy demands from the central station. This is possible only when large tractive efforts are exerted at low speeds, which follows from the fact that the power output of a motor is equal to the product of torque and speed. Torque depends upon the field flux and the current in the armature of the motor. The former varies with the field current, and, in an unsaturated motor, would be directly proportional to that current, but in practice it is less because of magnetic saturation. The speed of any motor depends upon the field flux, number of armature conductors, number of pairs of poles, and the counter electromotive force generated in the armature; thus

$$V_m = \frac{(E - I_a R) 60 \times 10^8}{2 p \Phi S} \text{ rev. per min.,}$$

where E is the impressed *E.M.F.*, I_a is the armature current in amperes, R is the motor resistance in ohms, including armature and all series coils, p is the pairs of field poles, Φ is the flux per pole in maxwells, and S is the number of armature conductors in series between brushes.

14. Direct-current Motors. — In a series direct-current motor the armature and field windings are connected in series and are traversed by the same current; therefore the torque exerted is roughly proportional to the square of that current. If a small current flows, the field strength will be low, and from the foregoing expression for speed it is seen that the speed will be high. Again, if the motor takes a large current, the field strength will be intense and consequently the speed will be low. Thus, a series motor exerting large torque runs at low speed, and when exerting little torque operates at high speed. It follows that the power consumption of a series motor does not fluctuate violently, and therefore is well suited for railway work.

In the shunt direct-current motor the field strength is approximately constant, and therefore the torque is directly proportional to the current and the speed is practically constant. When a large torque is required from such a motor its power consumption is enormous, since the speed is not materially lowered. Consequently the central station supplying equipment of this kind would be subject to great load variations. For this reason shunt motors are not used on railways.

The direct-current series motor operating at 500 or 600 volts has been in use since the advent of the electric railway. The commutating-pole series motor is now the standard for direct-current railways. Their use improves commutation, and permits the use of field control and high voltages. Fig. 11 shows the circuital relations of this motor.

The tendency being to reduce the initial investment of a railway system, its operation, particularly over long distances, must be effected at high voltages, since the principal

item of expense is the distributing system itself. But commutation difficulties limit the voltage of direct-current railway motors. Therefore it is usual to generate a high alternating electromotive force, preferably three-phase, at the power house, and to supply alternating current at this high voltage to a number of substations where, by means of transformers and converters, this current is changed to

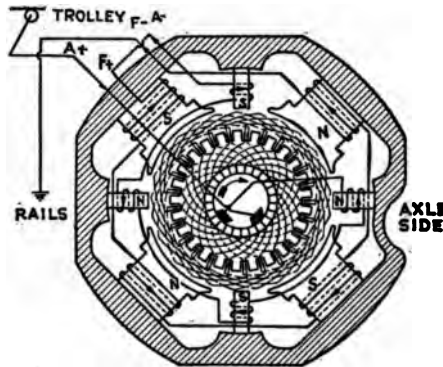

Fig. 11.

direct current, which is then supplied to the railway motors over the low-tension distribution system. Such generation and transformation entail large initial investment and operating expenses, and also considerable energy loss. These items may be greatly reduced by employing alternating-current motors, which can be operated at a potential of several thousand volts.

15. Alternating-current Motors. — The advantages incident to the use of the alternating-current motor are the lower first cost of the low-tension distribution system,

the substitution of the simple and efficient transformer substation for the converter substation, and the reduction of the cost of operation. It is not advisable to employ high trolley potentials in cities or densely populated suburban districts, but for trunk line operation, requiring an infrequent service, economical operation dictates high trolley potentials; in many cases transformation to a lower motor voltage is effected by transformers on the cars or locomotives. In alternating-current traction, controller systems may be utilized which do not entail the large energy losses incident to starting direct-current motors.

Three-phase generation is more economical than single-phase generation of *E.M.F.* The current from the former system may be converted into a two-phase current by means

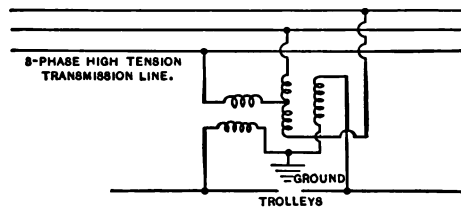

Fig. 12.

of a Scott transformer, each phase of which supplies single-phase current to the motors on one side of the station. Fig. 12 shows the scheme of connections. A single-phase load drawn from one phase of a large polyphase system unbalances the system for use otherwise. *Phase converters* or modifiers are used to restore this balance.

There are several types of alternating-current single-phase railway motors at present in operation, but of these the compensated series motor is the only one used in this country.

Series Motors. — Consider a direct-current armature mounted within a single-phase alternating magnetic field, as in Fig. 13. When the armature is stationary an electromotive force will be induced in the armature turns, due to the alternating flux which passes between the field poles. The greatest *E.M.F.*'s will be induced in the turns perpendicular to the field axis, since these turns link with

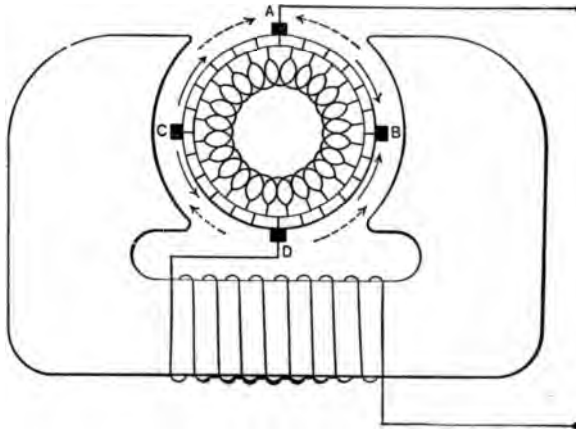

Fig. 13.

the greatest number of lines of force; and no *E.M.F.*'s will be induced in the turns in line with the field axis. The directions of the *E.M.F.*'s induced in the armature turns by the change in field flux are indicated in the figure by the full arrows, and it is seen that the maximum value of this *E.M.F.* is across *BC*. As in transformers, the effective value of this electromotive force is

$$E_T = \frac{2 \pi f \Phi_m N}{\sqrt{2} 10^8}, \quad (1)$$

where Φ_m is the maximum value of the flux entering the

armature and N is the equivalent number of armature turns.

The maximum number of lines of force linked with a single turn depends upon the position of this turn in the magnetic field, and is proportional to the greatest value of Φ_m times the cosine of the angle of displacement of the turn from the position AD . Assuming the turns to be evenly distributed over the periphery of the armature, the average value of the maximum flux linked with the armature turns will be $\frac{2}{\pi} \Phi_m$. If there be N_a conductors on the armature, the number of turns connected in continuous series will be $\frac{N_a}{2}$. The electromotive forces induced in the upper and lower groups of armature turns are added in parallel, consequently the effective number of turns in series between brushes is $\frac{1}{2} \cdot \frac{N_a}{2} = \frac{N_a}{4}$. Therefore the equivalent number of armature turns may be expressed as

$$N = \frac{2}{\pi} \cdot \frac{N_a}{4} = \frac{N_a}{2\pi}. \quad (2)$$

Substituting this value of N in equation (1), the *E.M.F.* induced in the armature winding by the change in value of the field flux is

$$E_T = \frac{f \Phi_m N_a}{\sqrt{2} 10^8}, \quad (3)$$

and it lags 90° behind the field flux in time.

If the brushes of the motor, A and D , are placed at the points shown in Fig. 13, this electromotive force will not manifest itself externally, since it consists of two equal and opposite components directed toward these brushes. This *E.M.F.* appears, however, in the coils short-circuited

by the brushes, as will be shown later. The current, which enters the armature by way of the brush and which traverses the two halves of its windings in parallel, produces an armature flux of maximum value Φ_{am} . This sets up a reactance *E.M.F.* in the armature which in the case of uniform gap reluctance can be similarly expressed as

$$E_a = \frac{f\Phi_{am}N_a}{\sqrt{2} 10^8}, \quad (4)$$

and lags 90° behind the current.

When the armature revolves, there are, in addition, electromotive forces induced in the armature conductors as a result of their cutting the field flux. The directions of these *E.M.F.*'s are indicated by the dotted arrows, and it is seen that these *E.M.F.*'s, generated by the rotation of the armature, add to each other and appear on the commutator as a maximum across *AD*.

The average value of the electromotive force due to the rotation of the armature in a bipolar field is

$$E_{rot\ av} = \Phi_f N_a \frac{V}{60} 10^{-8},$$

where *V* is the armature speed in rev. per min. and Φ_f is the field flux; and the effective value of this *E.M.F.* is

$$E_{rot} = \frac{\Phi_{fm} N_a}{\sqrt{2} 10^8} \cdot \frac{V}{60}, \quad (5)$$

and is in time phase with the field flux, but appears as a counter *E.M.F.* at the brushes *AD*.

When an alternating current is passed through the field coils, the alternating field flux is set up, and this flux produces a reactive *E.M.F.* in the field winding lagging 90° behind the flux in phase, exactly as in a choke coil. The magnitude of this *E.M.F.* is

$$E_f = \frac{2 \pi f \Phi_{fm} N_f}{\sqrt{2} 10^8}, \quad (6)$$

where Φ_{fm} is the maximum value of the field flux, and N_f is the number of field turns.

The electromotive force, E , which is impressed upon the motor terminals, is equal and opposite to the vectorial sum of E_a , E_{rot} , E_f , and the IR drop of the armature and field windings, as shown in Fig. 14, where I is the current

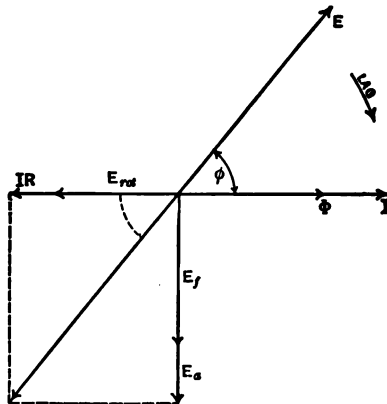

Fig. 14.

flowing through the field and armature, and Φ represents the phase of the flux. In this diagram, eddy current and hysteresis losses are ignored. The impressed electromotive force is therefore

$$E = \sqrt{(E_{rot} + IR)^2 + (E_a + E_f)^2}. \quad (7)$$

In the series motor, the same current passes through field and armature windings, and, if uniform reluctance around the air gap be assumed, then the armature and field fluxes will be proportional to the equivalent armature turns and field turns respectively. Representing by τ the ratio

of field turns to effective armature turns

$$\frac{\Phi_{am}}{\Phi_{fm}} = \frac{N}{N_f} = \frac{N_a/2\pi}{N_f} = \frac{1}{\tau} \quad (8)$$

whence $\Phi_{fm} = \tau\Phi_{am}$.

Substituting this value in (5), together with the equivalent of E_a/f to be derived from (4), there results

$$E_{rot} = \frac{\tau}{f} E_a \frac{V}{60}$$

and
$$E_{rot} = \frac{1}{f\tau} E_f \frac{V}{60}.$$

Neglecting the armature and field resistance drop, the impressed *E.M.F.* shown in (7) reduces to

$$E = E_a \sqrt{\left(\frac{\tau V}{60f}\right)^2 + (\tau^2 + 1)^2}, \quad (9)$$

which is the fundamental *E.M.F.* equation of the plain series motor.

The power factor of the motor is

$$\cos \phi = \frac{E_{rot}}{E} = \frac{\tau V}{60f \sqrt{\left(\frac{\tau V}{60f}\right)^2 + (\tau^2 + 1)^2}}, \quad (10)$$

and the current supplied to the motor is equal to the armature voltage E_a divided by its reactance, still neglecting motor resistance. Solving (9) for E_a there results

$$I = \frac{E_a}{X_a} = \frac{E}{X_a \sqrt{\left(\frac{\tau V}{60f}\right)^2 + (\tau^2 + 1)^2}}. \quad (11)$$

When $V = 60f$, the motor is said to run at synchronous speed (bipolar field). The power factor of a plain series motor, having $\tau = 1$, when running at this speed, is $\frac{1}{\sqrt{5}}$, or 0.446, and for values of τ other than unity the power factor is less than 0.446. It is true that if the resistance of the motor be considered, the power factor will exceed this value, but nevertheless it remains extremely low.

The current intake under these same conditions is $\frac{E}{\sqrt{5} X_a}$. When the motor is at standstill, $V = 0$, and the power factor is zero. The current intake at standstill is $\frac{E}{2 X_a}$. Hence the ratio of the current at synchronism to the current at standstill is $\frac{1}{\sqrt{5}} \div \frac{1}{2} = 0.894$. The ratio of the torque at synchronous speed to the torque at standstill, since it varies as the square of the current, is $\left(\frac{1}{\sqrt{5}}\right)^2 \div \left(\frac{1}{2}\right)^2 = 0.80$, which shows that the starting torque is but little greater than the torque at synchronous speed. Since for railway service motors are required having large starting torque and which torque rapidly decreases as the speed of the motor increases, it is seen that independent of its low power factor, the plain series motor, having uniform magnetic reluctance around the air gap, is unsuitable for traction and for similar purposes.

If, however, the reluctance of the air gap in the direction AD , Fig. 13, be increased, the power factor and speed-torque characteristics will be improved, and these will depend largely upon the ratio of field turns to effective armature turns, as will be seen by considering the construc-

tion of the motor to be such that the proportion, equation (8), must be modified by introducing into its antecedents a constant considerably greater than unity. A motor of this kind, with few field turns compared to armature turns, might be suitable for traction, but more important improvements have been made, which will now be discussed.

It appears from Fig. 14 that the power factor of series motors may be increased by increasing IR and E_{rot} , or by decreasing E_f and E_a . It is obvious that increasing IR signifies an increase in losses, thus resulting in a lower efficiency. E_{rot} can be increased by increasing the number of armature turns. Both E_f and E_a can be decreased by lowering the frequency without affecting E_{rot} , hence low frequencies are desirable. To decrease the reactive electromotive force of the field, it is necessary that the reluctance of the magnetic circuit be low, i.e., small air gap and low flux densities in the iron, in order that the required flux can be produced by a minimum number of ampere-turns. The armature reactive *E.M.F.*, E_a , is not essential to the operation of the motor, and can be neutralized by the use of compensating windings, and this feature of alternating-current series motors is a very important one.

The compensating winding is embedded in slots in the pole faces, as shown in Fig. 15, which represents a Westinghouse four-pole compensated single-phase railway motor with its armature and field windings removed. The number of turns of the compensating winding is adjusted so as to set up a magnetomotive force equal and opposite to that due to the current in the armature coils. The compensating winding may be energized either by the main current, by placing this winding in series with field and

armature, or by an induced current, which is obtained by short-circuiting the compensating winding upon itself, thus utilizing the principle of the transformer in that the main and induced currents are opposite in phase. The



Fig. 15.

former method of neutralizing E_a is known as *conductive* or *forced compensation*, and may be used with both alternating and direct currents, and the latter method is known

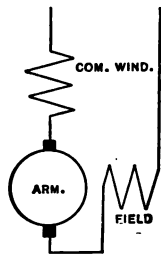

Fig. 16.

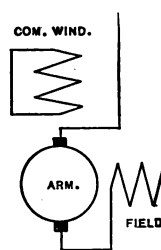

Fig. 17.

as *inductive compensation*, and may be used only with alternating current.

Figs. 16 and 17 show schematically the connections of the conductively and inductively compensated alternating-current series motors respectively. The compensating winding is preferably distributed so that the armature

reactance is neutralized as completely as possible. The current flows in the same direction in all of the conductors of the compensating winding embedded in one field pole, and flows in the opposite direction in the conductors embedded in the adjacent poles.

When the compensating winding completely neutralizes the armature reactance, the impressed electromotive force from equation (7) is

$$E = \sqrt{(E_{rot} + IR)^2 + E_f^2}, \quad (12)$$

where R is the resistance of the motor including that of the compensating winding. If R be neglected, then, since

$$E_{rot} = \frac{V}{60f\tau} E_f \quad \text{and} \quad E = E_f \sqrt{\left(\frac{V}{60f\tau}\right)^2 + 1},$$

the power factor is

$$\cos \phi = \frac{E_{rot}}{E} = \frac{V}{\sqrt{V^2 + (60f\tau)^2}}. \quad (13)$$

The motor current is

$$I = \frac{E}{X_f \sqrt{\left(\frac{V}{60f\tau}\right)^2 + 1}}. \quad (14)$$

At synchronous speed $V = 60f$, and therefore the power factor at this speed becomes $\frac{1}{\sqrt{1 + \tau^2}}$.

Still neglecting the motor resistance, the current intake at synchronous speed is $\frac{E\tau}{X_f \sqrt{1 + \tau^2}}$, and at standstill it is $\frac{E}{X_f}$, consequently the ratio of the current at synchronous

speed to the current at standstill is $\frac{\tau}{\sqrt{I + \tau^2}}$. Since torque varies as the square of the current, the ratio of the torque at synchronous speed to the starting torque is $\frac{\tau^2}{I + \tau^2}$.

Hence it follows that the speed-torque characteristics of a compensated series motor may be adjusted to the required conditions by properly proportioning the number of armature and field turns.

Repulsion Motors. — The repulsion motor, Fig. 18, has a field resembling the stator of the single-phase induction motor, and an armature which is similar to the armatures of direct-current and alternating-current series motors. The armature winding always remains short-circuited in

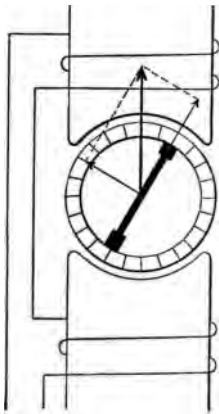

Fig. 18.

a line inclined at a definite angle with the field axis, this being accomplished by means of brushes, bearing on the commutator, which are joined together by a conductor of low resistance. The field winding is supplied with single-phase alternating current. The fact that the armature and field windings are electrically distinct makes it possible to operate the motor on high-voltage systems, the armature winding being so adjusted that the currents therein can be commutated satisfactorily.

The inclination of the short-circuit axis is essential to start the motor, for if perpendicular to the field axis the induced *E.M.F.*'s in the armature coils neutralize each other and there is no current, whereas if parallel with the field axis the torques on both sides of this axis are equal and

opposed. Modified forms of this motor by Atkinson have two field coils displaced in space by 90 electrical degrees, that of La Tour, Winter and Eichberg omits the field coil, its function being performed by the armature winding, and that of Deri has an additional pair of short-circuited brushes which alter the speed when shifted.

Induction Motors.—The three-phase induction motor may be used for traction purposes where the service require-



Fig. 19.

ments are of a constant nature, such as on long mountain grades. The induction motor is practically a constant-speed motor, the speed variation being less than about ten per cent of the no-load value, and therefore causes large energy demands on the central station. On the other hand, energy may be returned to the system when trains operated by them descend grades. This type of motor is adapted for heavy traction with infrequent stops. Two or three separate trolleys are necessary for such operation. Fig. 19 shows the motors and the method of their mountings on the trucks on the locomotives used in the

Cascade tunnel of the Great Northern Railroad. Six thousand six hundred volts are delivered to the locomotives from two trolley wires and the track rails, and are stepped down by transformers in the cab to 500 volts, which are impressed upon the motor terminals.

16. Methods of Drive. — Traction motors may drive the car wheels by means of gears, connecting rods, or driving pins. The first method is universally employed

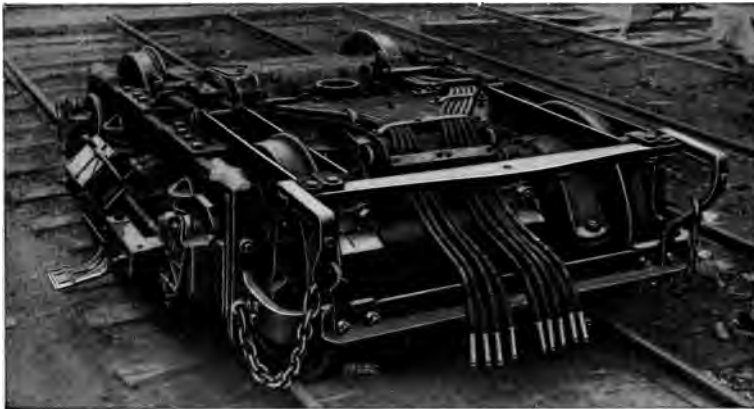

Fig. 20.

on street railways, the speed being reduced by a pinion on the motor shaft meshing with a gear wheel on the wheel shaft. Fig. 20 shows two geared G. E.-69, 200-horsepower direct-current motors mounted upon a truck, as used on the West Jersey and Seashore Railroad. The latter methods of drive are used in high-speed locomotive service. In the Pennsylvania electric locomotives the motors are mounted upon the frame and side-connected to driving wheels by a system of cranks and parallel connecting rods,



By Courtesy of the Railway Age Gazette.

Fig. 21.



Fig. 22.

By Courtesy of The Electric Journal.

similar to steam practice. Fig. 21 shows a truck of one of these locomotives with the cabs removed so as to show the method of mounting the motors. The connecting rods and all reciprocating parts are counterbalanced so as to eliminate pounding on the track. In the New Haven locomotives the motors are mounted upon a quill surrounding the driving axle, the torque being transmitted to the wheels directly by projecting pins on the armature structure engaging in sockets in the spokes of the driving wheels. Fig. 22 gives, at the top, two views of a quill, and at the bottom, two views of the quill in place upon the axle before the motor is mounted. In some installations, notably in the New York Central locomotives, the motor armatures are mounted directly on the driving axle, being rigidly connected thereto.

17. Motor Curves. — The characteristic curves of a motor include curves of speed, torque, and efficiency in terms of the current flowing through the motor. Instead of using the speed of the motor in revolutions per minute and the torque in pounds at one foot radius, it is usual in railway practice to plot the speed of the car in miles per hour and tractive effort or the force exerted at the rim of the car wheels in pounds. The relations between these quantities are given by the following equations, where V_m = motor r.p.m., T = pounds tractive effort, n_g and n_p are the respective numbers of teeth on gear and pinion, D = diameter of wheel in inches, T' = motor torque in lb.-ft., V = car speed in m.p.h. and ϵ_g = gear efficiency.

The work performed by the motor while its armature makes one revolution is $2\pi T'$. When multiplied by the gear efficiency it also represents the work done by the tractive effort in turning the car wheel through the corresponding portion, n_p/n_g , of a revolution. Therefore,

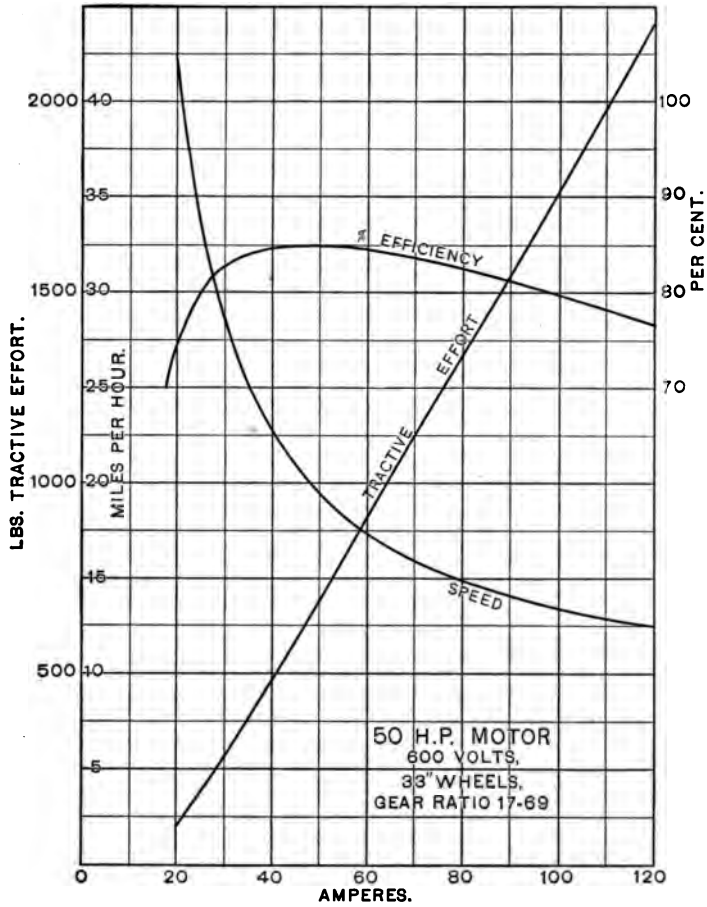

Fig. 23.

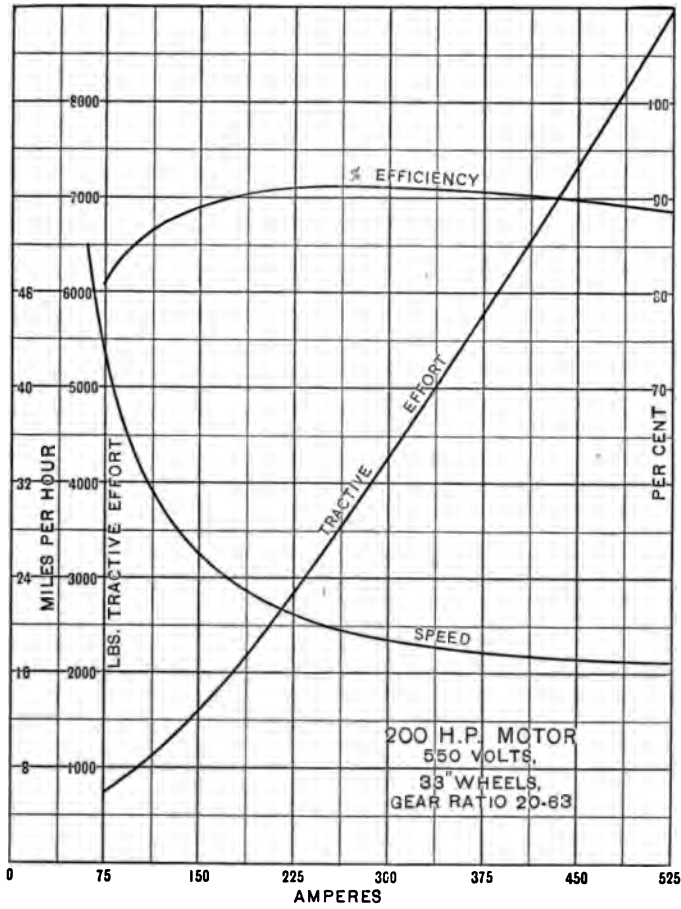

Fig. 24.

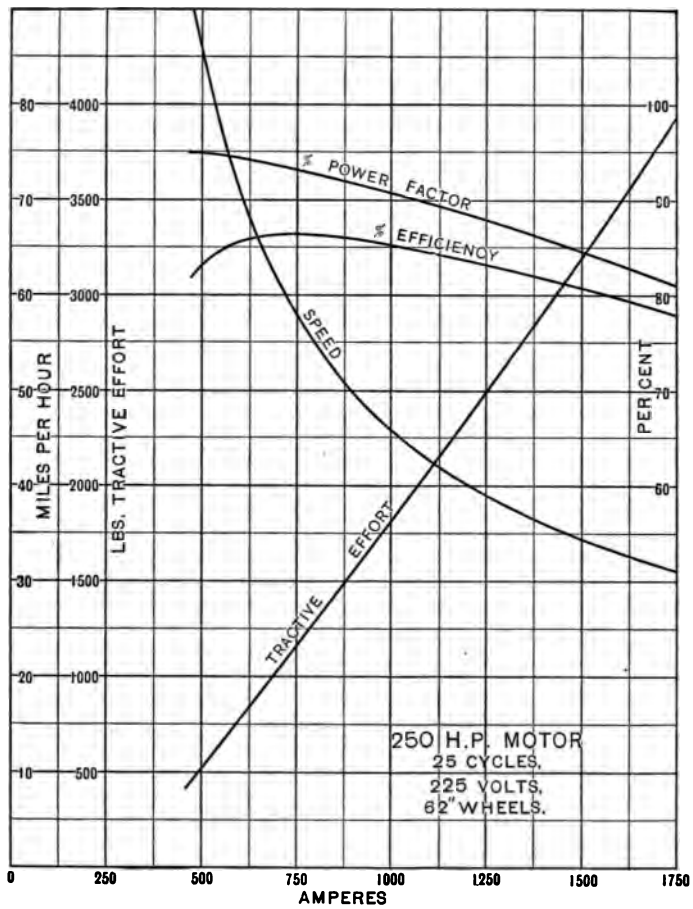

Fig. 25.

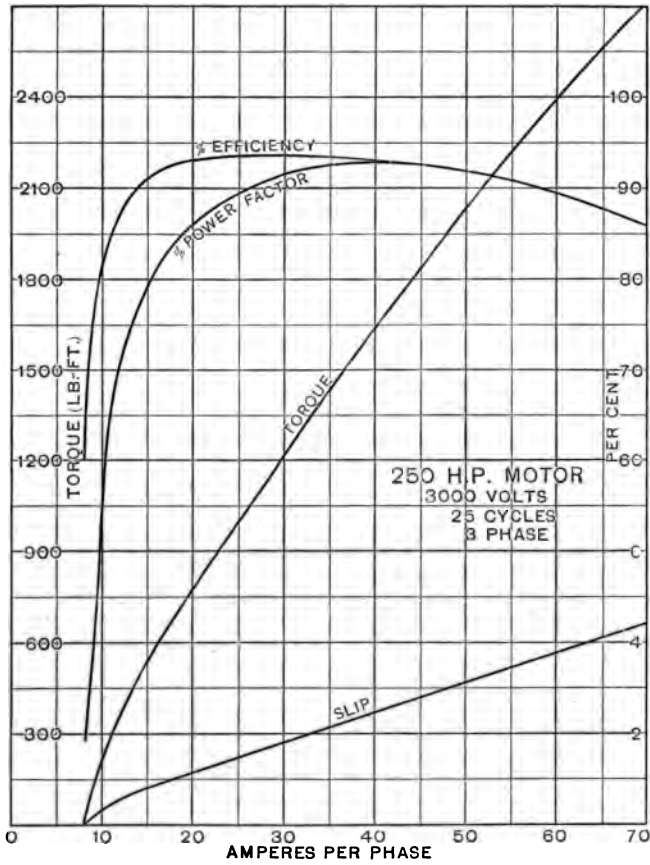

Fig. 26.

$$2 \pi \epsilon_g T' = 2 \pi D n_p T / 24 n_g \text{ foot-pounds.}$$

$$\therefore T = 24 n_g \epsilon_g T' / n_p D \text{ pounds.}$$

Equating the effective power exerted by the motor to the power exerted by the tractive effort,

$$2 \pi V_m \epsilon_g T' / 33,000 = 5280 VT / 60 \cdot 33,000 \text{ horsepower.}$$

$$\therefore V = 0.0714 \frac{\epsilon_g T'}{T} V_m \text{ miles per hour.}$$

Figs. 23 to 26 show respectively the characteristics of G.E. 216A motor, of the motor used by the I.R.T.Co. of N.Y.C., of the Westinghouse compensated single-phase motors used by the N.Y., N.H. & H.R.R., and of an induction motor.

PROBLEMS.

9. Plot a curve showing the ratio of the current taken by a compensated series motor at synchronous speed to that taken at standstill, coördinated to the ratio of the number of field turns to the effective armature turns.

10. The motor of an electric car having 33-inch wheels, when traveling at 25 miles per hour, exerts a torque of 550 pounds at one foot radius from the center of the armature shaft. If the gear ratio be 26 to 60, and the efficiency of the gears be 97 %, determine the tractive effort at the base of the car wheels, the horsepower, and the number of revolutions of the motor per minute.

11. Determine the horsepower output and speed of the induction motor whose characteristic curves are given in Fig. 26, when taking 50 amperes at 2850 volts. How many stator poles has the motor?

12. The gearless 25-cycle, single-phase motors used on the New Haven locomotives have 12 poles. Determine the velocity of the locomotives, which have drivers 62 inches in diameter, when the motors run at synchronous speed.

13. The total weight of a Pennsylvania electric locomotive is 166 tons, of which 104 tons are carried by the drivers, and the trailing load is 550 tons. What is the maximum grade this train can ascend with uniform velocity without slipping the wheels on clean dry rails? Neglect train resistance.

CHAPTER IV.

SPEED CURVES.

18. Motor Limitations. — The size of the motors to be installed on cars so that they may perform a proposed service must be such that the motors will exert the necessary tractive effort for the prescribed acceleration and operate without overheating. As the tractive effort exerted by a motor depends upon its current intake, and the maximum current which may be supplied to the motor depends upon commutation, it is seen that the rate at which a car may be accelerated is dependent upon the allowable current input. Another limitation to the rate of acceleration, besides the consideration of comfort to passengers, is expressed by the coefficient of friction or adhesion, that is, the ratio of the tractive effort necessary to cause slipping of the wheels on the rails to the total weight on the *drivers*. This coefficient depends upon the condition of the track. The following values are approximate and are based upon a uniform torque exertion:

Clean dry rails.....	0.30
Wet rails.....	0.18 (with sand 0.25)
Sleet-covered rails.....	0.15 (with sand 0.20)
Snow-covered rails.....	0.10 (with sand 0.15)

It is seldom necessary to apply motors to every axle, economy dictating that the number of axles equipped be as small as possible and as permitted by the coefficient of adhesion. In train operation some cars are equipped with motors while others are mere trailers without motors.

The heating of motors in service is determined by the square root of the mean square current supplied to the motor and the average voltage across the motor terminals. This mean square current is obtained from a series of instantaneous current values taken over a considerable time interval, as shown later. Thus, a motor should be selected which will commutate the abnormal current taken during the period of acceleration without excessive sparking at the brushes and also perform the required service without excessive temperature rise.

19. Motor Capacity. — To determine the motor capacity for a proposed service, a knowledge of the load under which the motor must operate is essential. This load is of an exceedingly variable nature, fluctuating between no load at stopping points and a maximum load, which occurs during starting of the car. The method of procedure is as follows: a trial equipment is assumed (a guide to its selection may be obtained from a comparison of the equipments of similar existing installations), and from the motor performance curves there are plotted curves of speed of the car in traversing the entire roadway and of motor current. The former curve enables one to foretell if the prescribed schedule speed can be maintained, allowing a reasonable margin for making up delays, and the latter curve serves as the basis for determining whether the assumed motor can perform the required service without such extreme heating as to endanger the insulation.

20. Speed. — The velocity of a car in operation varies widely from time to time. Starting from standstill, the car is accelerated, rapidly at first, then more and more slowly until a uniform speed is attained. After running at this speed for a definite time, the current is turned off

and the car is allowed to coast, the velocity meanwhile gradually decreasing. Finally the brakes are applied in order to bring the car rapidly to rest at the next stopping

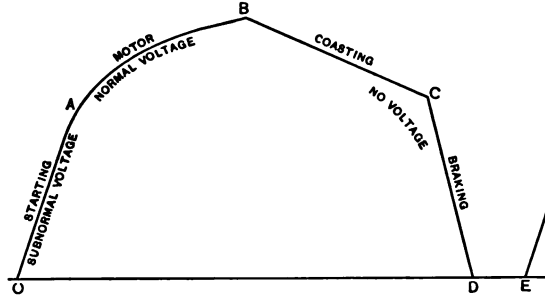

Fig. 27.

point. Here freight or passengers are taken on or discharged; thereafter similar runs are performed.

21. Typical Speed Curves. — The velocity of a car at successive instants of time may be graphically portrayed by a *speed curve*, in which the instantaneous speeds are plotted in terms of time. Such a curve takes the form of a series of lobes, each one representing a *run* and one of which is shown in Fig. 27. The slope of the curve at any point indicates the time rate of change of speed. This slope may be positive, zero, or negative, corresponding respectively to acceleration, uniform speed, or retardation.

The speed curve may be considered as made up of four parts as follows: *starting*, *motor*, *coasting*, and *braking*. The starting part corresponds to the period of manipulation of the controller, the acceleration of the car and the current in the motor being kept constant, while the voltage impressed upon the motor is gradually increased from zero to its normal value. The motor part corresponds to a

gradual decrement of acceleration of the car and of motor current, normal voltage being impressed upon the motor. The coasting part corresponds to the movement of the car under its own momentum, no current passing through the motor. The braking part corresponds to the period during which the car is being quickly brought to rest by the absorption of energy at the brake shoes. The starting and motor parts are often considered together as constituting the *acceleration* part of a speed curve.

The ordinate B of the speed curve represents the maximum velocity of the car during the particular run, and the horizontal line DE shows the duration of standstill at the subsequent stop. The schedule speed of the car is obtained by finding the area of the speed curve over the entire roadway and dividing by the total time taken therefor inclusive of stops. This time is the interval between A of the first run and E of the last one. The shorter the time of stops the greater will be the schedule speed, other conditions remaining unaltered. The greater the rates of acceleration and retardation the greater will be the schedule speed provided the same maximum speed is attained. If the rate of braking be too high the car wheels will slide on the rails, and there will be a tendency for the car body to move ahead over the trucks. The maximum practicable braking rate is considered to be 2.5 miles per hour per second.

22. Data for Plotting Speed Curves. — The plotting of a speed curve for a proposed equipment over a typical run requires a knowledge of the following conditions:

- Type of motor,
- Number of motors per car or train,
- Motor performance curves at full line voltage and at a definite gear ratio,

Total weight of the car with live load,
Plan and profile of the roadbed,
Schedule speed required,
Rates of acceleration and braking, and
Duration of stops.

For single-car operation (double-truck cars) a four-motor equipment is preferable, whereas for train operation two-motor equipments are generally used, and sometimes both motors are placed on one truck.

The performance curves of a railway motor show its characteristics at normal voltage under any load. When starting the series motor, the voltage impressed upon its terminals is low at first, and is gradually increased by means of a controller, which cuts out resistance or, with single-phase motors, decreases the ratio of transformation of a compensator. With suitably designed controllers properly operated the current supplied to the motors will be roughly uniform until the full line voltage is impressed upon the terminals of each motor. The torque exerted, being proportional to the current intake, will also be uniform. After the line voltage is applied to the motors, their performances are entirely dependent upon their characteristics.

It is essential to have a reliable estimate of the weight of the tentative car for a proposed service, this weight to include live load, electrical equipment, and brake apparatus. Weights of car bodies and trucks are given in Chapter I. The average weight of passengers may be taken as 140 pounds per individual. The weights in pounds of some standard 600-volt electrical equipments having commutating-pole railway motors, made by the General Electric Co. and the Westinghouse Electric & Manufacturing Co., for direct-current railways follow:

Trade Name.	H. P.	Weight of Each Motor Including Gears and Case.	No. of Motors.	Type of Control.	Weight of Control Apparatus.	Total Weight of Equipment.		
General Electric Co.	258.....	25	885	2	K-63	750	2520	
				4	K-35	1285	4825	
	247....	40	1740	4	PC†	1335	4875	
				2	K-63	755	4235	
	216A*..	50	2885	4	K-35	1490	8450	
				4	PC†	1490	8450	
	203.....	50	2280	2	K-11	1015	6785	
				4	K-14	2250	13790	
	201....	65	2845	4	†	2070	13610	
				2	K-36	1100	5660	
	240.....	105	3840	4	K-35	1520	10640	
				4	PC†	1600	10720	
	Westinghouse Elec. & Mfg. Co.	506A...	25	913	2	K-63-B	750	2576
					4	K-35-G-2	1228	4880
514C...		40	1795	4	HL†	1610	5262	
				2	K-63-B	822	4412	
532B...		50	2340	4	K-35-G-2	1550	8730	
				4	HL†	1610	8790	
306CV4.		65	2675	2	K-36-J	1156	5836	
				4	K-35-G-2	1654	11014	
548C...		100	3195	4	HL†	1769	11129	
				2	K-36-J	1191	6541	
557A8..		140	4050	4	K-35-G-2	1894	12594	
				4	HL†	2032	12732	
				2	K-35-G-2	1642	8032	
				2	HL†	1645	8035	
			4	HL†	2654	15434		
			2	HL†	2105	10205		

* Without commutating poles.

† Multiple unit.

The weights of single-phase motors somewhat exceed the foregoing values for the same capacity, but owing to their limited adoption up to the present time, the design of this type of motor has not yet become standardized.

The dimensions of the car chosen for the proposed railway should be known, particularly those dimensions which limit the minimum permissible radius of track curvature,

the clearances on each side of the track at curves, and the maximum possible size of motor which can be installed on the truck.

The physical characteristics of a roadway are usually embodied in a map and profile of the route showing the length of line, proposed regular stations, junctions and crossings with existing roads, switches and branch lines, and the location and extent of grades and curves.

A subdivision of the total length of the road into city, suburban, and interurban sections can usually be effected. Different operating conditions obtain in these sections, because the schedule speeds and length and frequency of stops are not the same for all. Representative values for these factors follow.

Service.	Schedule speeds in miles per hour.	Average dura- tion of stops in seconds.	Number of stops per mile.
Interurban express.....	35 to 60	60	0.05 to 0.2
Interurban local.....	25 to 40	30	0.3 to 0.7
City rapid-transit express...	20 to 30	25	0.4 to 1.0
Suburban.....	15 to 20	15	1 to 2.5
City elevated or subway (local).....	15 to 20	12	2 to 3
City surface lines.....	8 to 12	7	5 to 10

The choice of gear ratio for the trial equipment should be such that the peripheral velocity of the motor armature when the car is running at its highest speed will not be excessive. The ratio of the maximum speed to the schedule speed varies between 1.2 and 1.8, this ratio increasing as the runs become shorter and the duration of stops becomes longer. This enables the selection of the proper gear ratio.

23. Plotting Speed Curves. — To understand the method commonly used in plotting speed curves consider the dif-

ferent portions of the curve in Fig. 28 and the following formula for the car acceleration (see § 11):

$$A = \frac{T_m - T_t}{100 W'}, \quad (1)$$

where T_m is the tractive effort exerted by a motor, T_t is the train resistance per motor, and W' is the weight of the car or train per motor. Then

$$T_m = T_t + 100 W'A. \quad (2)$$

The *starting* part of a speed curve is taken as a straight line, and it passes through O , the origin of time, at an angle θ_A with the horizontal such that $\theta_A = \tan^{-1}A$, where

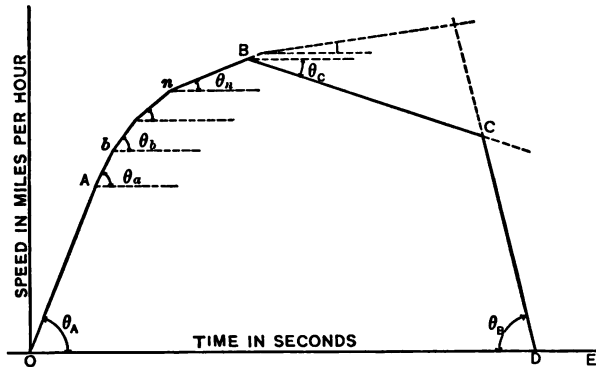

Fig. 28.

A is the assumed constant rate of acceleration at starting. It terminates at the point A having a speed ordinate taken from the motor characteristic curves for full voltage corresponding to the tractive effort T_m calculated from equation (2), in which T_t is based on half schedule speed.

The *motor* part of the speed curve is considered as made up of a series of elements which are themselves straight. The speed ordinate of the upper end of any element is

assumed, while that of its lower end is the same as for the upper end of the preceding element. This element makes with the horizontal an angle $\theta_n = \tan^{-1} A_n$, where A_n is the average of the accelerations corresponding to the speeds at the terminals of the element and each calculated by means of formula (1). The calculation of these elements is greatly facilitated by two auxiliary curves, one showing the relation between motor tractive effort and speed and the other between train resistance and speed.

The *coasting* part is generally assumed to be straight, although it really is concave towards the time axis. It is drawn from an assumed point B and makes with the horizontal an angle $\theta_c = \tan^{-1} A_c$, where A_c is calculated from formula (1), whose terms are based upon the speed V which is the ordinate of the point B . The other end, C , of this part of the curve is determined by the intersection with the remaining part.

The *braking* part of the speed curve is also assumed to be straight, passes through the time axis at D corresponding to the specified expiration of the run, and makes with the horizontal an angle $\theta_b = \tan^{-1} A_b$, where A_b is the assumed rate of braking.

The method just outlined assumes that equal distances along the two axes have the same numerical value; for example, if one inch along the horizontal axis of Fig. 28 represents 50 seconds, then one inch along the vertical axis must correspond to 50 miles per hour. If, for convenience, other than equal value scales are used, the parts of the speed curve cannot be constructed by laying off the angles as described, but instead, by measuring the horizontal and vertical components on cross-section paper according to their individual scales. Thus, in laying out the motor part of a speed curve, the abscissa increment, in seconds, for an

element may be determined by dividing the speed increment in miles per hour by the average acceleration in miles per hour per second, or symbolically $\Delta t = \Delta V/A$.

24. Numerical Example.— The process of plotting a speed curve is best illustrated by considering a specific case, as follows:

(a) *Data.* Car, single car to seat 40 passengers and to accommodate an equal number standing, weighing with trucks 23,650 pounds. Cross section, $S = 95$ square feet.

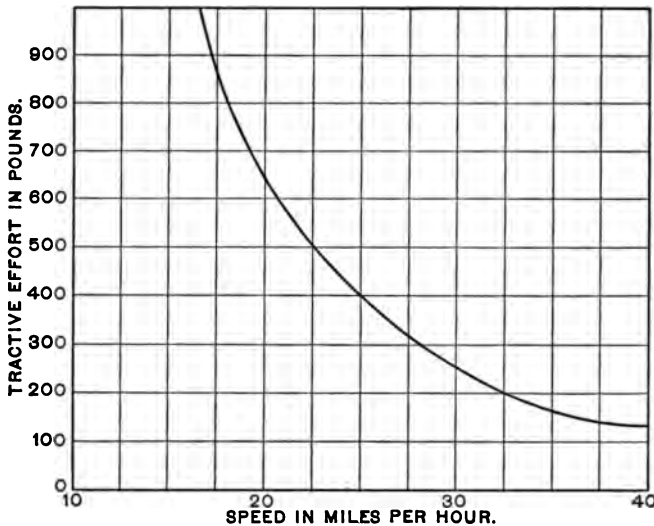

Fig. 29.

Trial equipment: four direct-current 50-horsepower, 600-volt G.E. 216A motors with Type K-14 control; total weight is 13,790 pounds, § 22. Characteristic curves of motors are shown in Fig. 23 for a gear ratio of 17 to 69. From these curves a new curve, Fig. 29, of tractive effort per motor and speed is plotted for convenience.

Run, 0.8 mile run on a straight level track. Schedule speed = 20 miles per hour. Length of stop = 20 seconds. Initial acceleration rate = 1.5 miles per hour per second. Braking rate = 2 miles per hour per second.

The total weight of the car with live load is

$$W = 23,650 + 13,790 + (80 \times 140) = 48,640 \text{ pounds} \\ = 24.32 \text{ tons.}$$

The total train resistance is

$$T_T = 50 \sqrt{W} + \frac{WV}{25} + \frac{SV^2}{400} = 246 + 0.97 V + 0.238 V^2.$$

Fig. 30 shows the relation which exists between the train resistance per motor $T_t = T_T/4$ pounds and the speed V miles per hour.

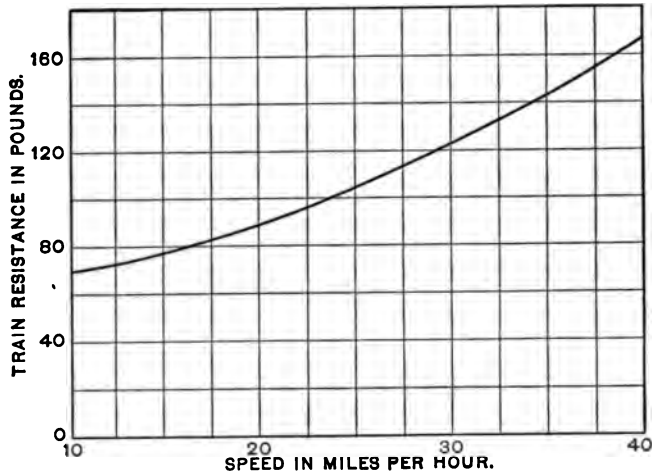

Fig. 30.

(b) *Acceleration at Subnormal Voltages.* To produce an acceleration of 1.5 miles per hour per second requires a net tractive effort of

$$100 WA = 100 \times 24.32 \times 1.5 = 3648 \text{ pounds,}$$

or a net tractive effort of $3648 \div 4 = 912$ pounds per motor. To neutralize train resistance during the period of initial acceleration additional tractive effort must be exerted. The amount may be taken equal to the train resistance at half schedule speed, that is, at 10 miles per hour. Its value is found from Fig. 30 to be 70 pounds per motor. Therefore the total tractive effort to be exerted by each motor in starting is

$$T_m = 912 + 70 = 982 \text{ pounds.}$$

This tractive effort is produced when each motor takes 64 amperes at 600 volts, as shown by the motor performance curves, Fig. 23; and the corresponding speed of the car is 16.9 miles per hour. Thus, the current consumed as the car is accelerated uniformly at the prescribed rate from standstill to a speed of 16.9 miles per hour is maintained roughly constant by the controller at a mean value of 64 amperes. The time required to attain this speed is $\frac{V}{A} = \frac{16.9}{1.5} = 11.3$ seconds. This represents the first point of the speed curve, and is shown at *A* in Fig. 31. Since the acceleration during the first 11.3 seconds of the run was approximately uniform, the speed curve over this interval may be drawn as a straight line, as *OA*.

(c) *Acceleration at Normal Voltage.* The full line voltage is applied to each motor when the speed of 16.9 miles per hour is reached, and thereafter the acceleration be-

comes less and less because the current decreases as the car speeds up and this results in a lower available tractive effort. Increased train resistance at higher speeds is also instrumental in lowering the acceleration rate. To obtain other points of the speed curve, the car is supposed to be running at some higher speed, say 20 miles per hour. At this speed the motor current will be 48.2 amperes, the total tractive effort will be 660 pounds per motor, and the train resistance will be 90 pounds per motor. The net tractive effort producing acceleration is $660 - 90 = 570$ pounds; whence the rate of acceleration at a speed of 20 miles per hour is

$$A_b = \frac{T_m - T_t}{100 W'} = 570 \div \left(100 \times \frac{24.32}{4} \right) = 0.94 \text{ mile per hr. per sec.}$$

The average acceleration during the period in which the velocity of the car increased from 16.9 to 20 miles per hour may be taken without serious error as the mean of the initial and final acceleration rates of the period. The time required to gain this velocity increment is, of course, the increment divided by the average acceleration, which in this case is

$$\Delta t = \frac{20 - 16.9}{\frac{1.5 + 0.94}{2}} = \frac{3.1}{1.22} = 2.54 \text{ seconds.}$$

Thus, the second point of the speed curve shows a velocity of 20 miles per hour at $11.3 + 2.54$, or 13.84 seconds (*b*, Fig. 31).

This process is continued with small velocity increments until the speed of the car becomes constant. A tabulation of the values so obtained follows; the various points are indicated on the curve.

SPEED CURVES.

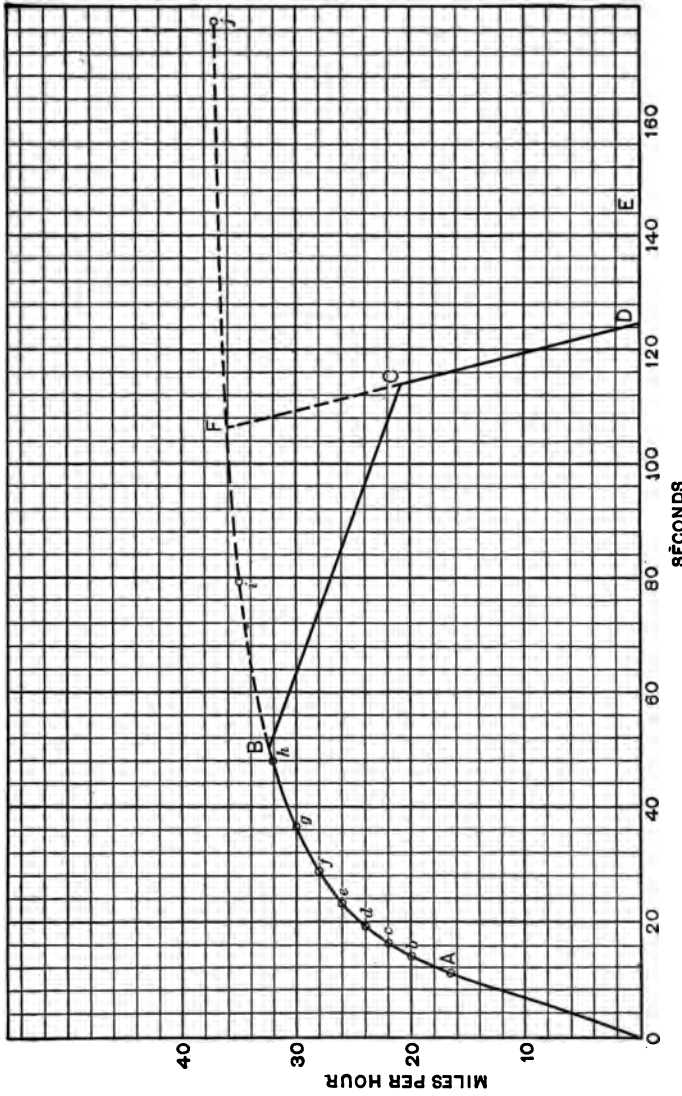

Fig. 31.

Point.	Speed, V.	Tractive effort, T_m .	Train resistance, T_r .	Net tractive effort, $T_m - T_r$.	Accelera- tion rate, A.	Total time.
A	16.9	912	1.50	11.30
b	20	660	90	570	0.94	13.84
c	22	530	96	434	0.714	16.26
d	24	430	102	328	0.540	19.45
e	26	360	108	252	0.415	23.65
f	28	300	115	185	0.304	29.22
g	30	255	122	133	0.219	36.88
h	32	220	130	90	0.148	47.78
i	35	170	145	25	0.041	79.6
j	36.8	152	152	0	0	177.0

(d) *Braking.* After plotting the entire acceleration curve of a car with an assumed electrical equipment for a particular run, the speed curve is completed by drawing the coasting and braking curves. Since the time of passage over a section of the road is specified by the schedule speed and the average duration of a stop, it is necessary to construct the braking curve first so as to determine how much coasting may be permitted and still bring the car to the next station in the required time.

In the numerical illustration the car is to travel 0.8 mile at a schedule speed of 20 miles per hour, which means that the time required for this run is $\frac{0.8 \times 3600}{20} = 144$ seconds.

But this time includes a stop of 20 seconds; therefore the actual running time is 124 seconds. The braking curve may now be drawn through this point on the time axis at a slope corresponding to the braking rate and extending to its intersection with the acceleration curve at *F*. It should be drawn as a straight line, and, since the braking rate is specified at 2 miles per hour per second, the line will pass through the point which indicates that the veloc-

ity of the car is $2 \times 10 = 20$ miles per hour at a time of $124 - 10 = 114$ seconds from the beginning of the run.

(e) *Coasting.* Since the ordinates of a speed curve are velocities and the abscissæ are times, the area of such a curve will be expressed in units of velocity \times time, or $\frac{\text{distance}}{\text{time}} \times \text{time}$, or simply in units of distance. Thus,

in Fig. 31, the area of a large square is 10 miles per hour \times 20 seconds = 200 mile-seconds per hour = $\frac{200}{3600}$ or $\frac{1}{18}$ mile. The area enclosed by a speed curve is therefore a measure of the distance traversed by the car.

The speed curve drawn thus far allows for no coasting, and the area enclosed thereby may be less than, but in general will exceed, that representing a run of 0.8 mile. For a run of this length the speed curve must enclose exactly $0.8 \div \frac{1}{18} = 14.4$ large squares. In order to obtain just this area, the position of the coasting curve *BC* is varied until properly located; its slope, however, cannot be taken at random.

When the current supply to the motors is discontinued the car tends to run at constant speed, but train resistance retards the motion and produces a negative acceleration. As train resistance depends upon the speed, the coasting curve will not be strictly a straight line, but will have a slight curvature tending to become more nearly horizontal at lower speeds. It is usual to draw the coasting line straight and at a slope corresponding to the train resistance value at the speed at which the car is running when the power is cut off.

The coasting curve is drawn at the proper inclination in a trial position and the resulting area of the speed curve is determined. If the area be different from the proper

value the line is shifted parallel to itself up or down as the case may be, until the enclosed area is found to be correct. Should the coasting curve require considerable shifting so that it commences at a somewhat different speed value, then its inclination must be redetermined on this basis. The area of the curve *AFD* of Fig. 31 is 16.8 large squares, and the position of the coasting curve was adjusted so that the enclosed area *ABCD* is equal to 14.4 squares; thus the speed curve truly depicts a 0.8 mile run. The train resistance at the speed where coasting begins is 130 pounds per motor. The negative acceleration produced thereby is $\frac{130}{100 \times (24.32 \div 4)} = 0.21$ mile per hour per second, a value giving the proper slope of the coasting line.

Had the area of *AFD* been less than 14.4 squares, the curve would have indicated that the chosen equipment is incapable of maintaining the specified schedule speed under the given conditions. In such cases other curves should be drawn for the same equipment with lower gear ratios, or for other equipments comprising larger motors. On the other hand, if the excess area be unduly large, other speed curves corresponding to higher gear ratios or smaller motors should be constructed. A reasonable margin should, however, be allowed for making up for delays. The equipment ultimately selected for the given service should be able under emergency conditions to make a complete trip in 5 to 15 % less running time than that allowed for regular service.

25. Distance Curves. — Speed curves of cars over runs having grades or curves are more difficult to construct than those over a tangent level roadway. Here the additional tractive effort required for propelling a car or train

up a grade or around a curve must be considered, and indeed, these additional forces are applied at definite places on the run. This implies a knowledge of the exact location of the car at every instant of time, so that these influences may be properly represented on the speed curve. The instantaneous positions of a car are shown most conveniently by a *distance curve* plotted in terms of time.

The distance curve for the run mentioned in the foregoing is plotted as follows: The average velocity over the first 11.3 seconds of the run is $\frac{1}{2}(0 + 16.9) = 8.45$ miles per hour, and therefore the space traversed during this period is $\frac{11.3 \times 8.45}{3600}$ mile, or $\frac{95.4 \times 5280}{3600} = 95.4 \times 1.467 = 140$ feet. The average velocity over the next 2.54 seconds is $\frac{1}{2}(16.9 + 20.0) = 18.45$ miles per hour, and the distance traveled during this time interval is $18.45 \times 2.54 \times 1.467 = 68.6$ feet. This process is continued over the entire running time, and the final sum should be equal to $0.8 \times 5280 = 4224$ feet. The speed and distance curves are generally plotted simultaneously, using for convenience the same time increment values.

26. Speed Curve Plotting with Grades and Curves. — As an illustration of the method of plotting speed curves over

runs having grades and curves, consider the same car and equipment making a 0.9 mile run over a roadway the plan of which is shown in Fig. 32; all other conditions to remain unaltered.

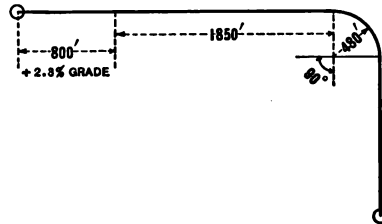

Fig. 32.

As before, to produce an acceleration of 1.5 miles per hour per second on a level track requires

$$1.5 \times 100 \times \frac{24.32}{4} = 912 \text{ pounds per motor,}$$

and to overcome train resistance 70 pounds additional must be exerted. But as the car must be accelerated on a 2.3% up grade, a further tractive effort must be exerted amounting to

$$20 \times 2.3 \times 6.08 = 280 \text{ pounds per motor.}$$

This total force of 1262 pounds is produced when each motor takes 77 amperes, as obtained from Fig. 23, and this current value is maintained moderately uniform until the motors operate on the full line voltage of 600 volts, which occurs when the car has attained a speed of 15.3 miles per hour. The time required therefor is $\frac{15.3}{1.5} = 10.2$ seconds, and the distance traversed during this interval with uniformly accelerated motion is $\frac{15.3}{2} \times 10.2 \times 1.467 = 114$ feet.

These values constitute the first points respectively of the speed and distance curves for this particular run, and are shown at *A* and *a'* on the curves of Fig. 33.

When the speed of the car has reached 18 miles per hour the total tractive effort exerted by each motor is 840 pounds. The grade resistance is still 280 pounds, but the train resistance at this speed is now 84 pounds per motor. Therefore the net tractive effort producing acceleration is $840 - (280 + 84) = 476$ pounds; whence the rate of acceleration at the instant the velocity of the car is 18 miles per hour is

$$\frac{476}{100 \times 6.08} = 0.78 \text{ mile per hour per second,}$$

SPEED CURVES.

6

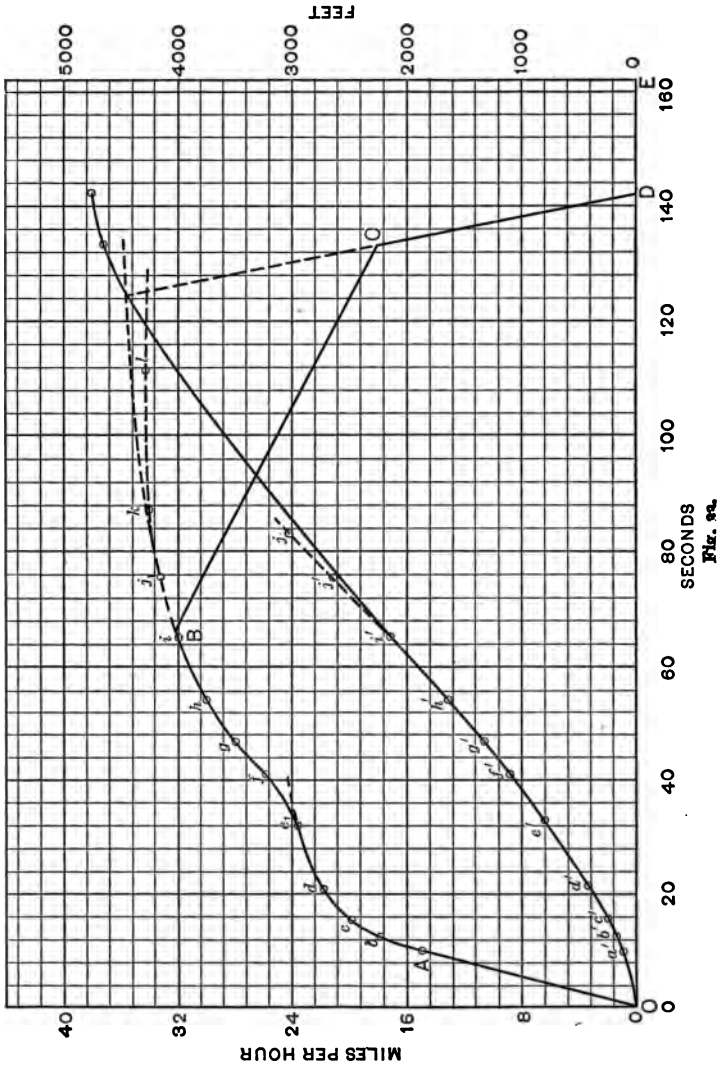

Fig. 9a.

The time required for the car to gain this velocity increment of 2.7 miles per hour is

$$2.7 \div \frac{1}{2} (1.5 + 0.78) = 2.36 \text{ seconds,}$$

and the space traversed during this interval is

$$2.36 \times \frac{1}{2} (15.3 + 18.0) \times 1.467 = 57.5 \text{ feet.}$$

Thus, 12.56 seconds after the car started from rest it acquired a speed of 18 miles per hour and covered a distance of 171.5 feet. These values constitute second points respectively on the speed and distance curves, and are indicated at *b* and *b'* in Fig. 33. Other points are similarly determined, as noted in the following table, the process being continued until a distance of 800 feet has been passed over by the car. At this place the grade ceases and the remainder of the run is on a level track.

Point on speed curve.	Speed.	Total tractive effort.	Train resistance.	Net tractive effort.	Rate of acceleration.	Time increment.	Total time.	Space increment.	Total distance.
<i>A</i>	15.3	1262	1.50	10.2	10.2	114.0	114.0
<i>b</i>	18	840	84	476	0.78	2.36	12.56	57.5	171.5
<i>c</i>	20	660	90	290	0.48	3.18	15.74	88.6	260.1
<i>d</i>	22	530	96	154	0.25	5.48	21.22	168.9	429
<i>e</i>	24	430	102	48	0.079	12.15	33.37	409	838
<i>e</i> ₁	23.9	435	102	53	0.088	11.21	32.43	376	805

It is seen in the table that point *e* was corrected in order to approximate the distance of 800 feet more closely.

Beyond the grade the net tractive effort for producing acceleration becomes larger by the amount of 280 pounds per motor, and thus the speed of the car increases more rapidly than before. Continuing the tabulation until the

car strikes the curve, there obtains (compare with points *e* to *h* of table of § 24) the following:

Point on speed curve.	Speed.	Total tractive effort.	Train resistance.	Net tractive effort.	Rate of acceleration.	Time increment.	Total time.	Space increment.	Total distance.
<i>f</i>	26	360	108	252	0.415	8.35	40.78	305	1110
<i>g</i>	28	300	115	185	0.304	5.57	46.35	220	1330
<i>h</i>	30	255	122	133	0.219	7.65	54.0	326	1656
<i>i</i>	32	220	130	90	0.148	10.90	64.9	495	2151
<i>j</i>	34	185	139	46	0.072	18.20	83.1	880	3031
<i>ji</i>	33.3	198	135	63	0.104	10.30	75.2	493	2644

Since the car encounters a curve after running 2650 feet, a readjustment of point *j* of the speed curve was necessary, because after passing this place the rate of acceleration of the car decreases since some tractive effort is required to neutralize the increased flange friction. Taking this as 0.5 pound per degree per ton for simplicity, the additional tractive effort is $\frac{5780}{480} \times 6.08 \times 0.5$, or 36 pounds. The length of the curve is $480 \pi \div 2 = 754$ feet; that is, the curve ends at a distance of 3404 feet from the starting point. The figures in the following table refer to the car movement on the curve of 480 feet radius.

Point of speed curve.	Speed.	Total tractive effort.	Train resistance.	Net tractive effort.	Rate of acceleration.	Time increment.	Total time.	Space increment.	Total distance.
<i>k</i>	34	185	139	10	0.0165	11.62	86.82	573	3217
<i>l</i>	34.2	181	145	0	0	24.22	111.04	1212	4429

Had the curve extended over a greater distance the ultimate velocity of the car thereon would have been 34.2 miles

per hour; but the curve ends before this velocity is acquired and thereafter the car runs on a tangent level track. The time when the car emerges from the curve is shown by the distance curve of Fig. 33, and the acceleration curve from this time on may now be completed along the lines previously outlined. The braking and coasting curves are then drawn in their proper positions, so that the enclosed area truly represents a 0.9 mile run. The completed speed curve is shown as *OABCDE* in Fig. 33.

By reference to this curve it is seen that the power is cut off from the car when its velocity is 32.1 miles per hour and when it has been running for 65.6 seconds. During this time the car traveled 2175 feet, as indicated by the distance curve. While the car is coasting for 67.4 seconds it passes over

$$67.4 \times \frac{1}{2} (32.1 + 17.9) \times 1.467 = 2465 \text{ feet.}$$

Thus the brakes are applied when the car is distant 4640 feet from the starting point. The time required to bring the car to rest from a velocity of 17.9 miles per hour at the prescribed rate of braking is 8.95 seconds, and the distance traveled during this period is $8.95 \times \frac{17.9}{2} \times 1.467 = 117 \text{ ft.}$

Thus the total length of the run as determined by summation of the separate distances is 4757 feet, a value which exceeds the true length of run by but 5 feet. Distance curves therefore serve as admirable checks in the plotting of speed curves.

PROBLEMS.

14. Plot a complete acceleration curve of a car weighing 20 tons with live load and equipped with two 50-horsepower, direct-current motors whose characteristic curves are given in Fig. 23. The initial acceleration rate is to be 1.3 miles per hour per second and the schedule speed is specified at 15 miles per hour on a tangent level track. What is the maximum possible velocity of this car on such a roadway?

15. Complete the speed curve of the equipment mentioned in problem 14 over a $\frac{3}{4}$ -mile level roadway, allowing a 15-second stop at the following station. The braking rate is specified at 1.5 miles per hour per second.

16. What is the shortest running time that a motor car weighing 43 tons total with passengers and equipped with two 200-horsepower, 550-volt, direct-current motors whose characteristic curves are shown in Fig. 24, can complete a one-mile run up a uniform grade of 1.5 %? The acceleration and braking rates are 2 miles per hour per second.

17. An 8-car New York Subway train having five motor cars each equipped with two 200-horsepower, 550-volt motors, weighs 320 tons including live load. The characteristic curves of the motors are shown in Fig. 24. Plot the acceleration portion of the speed curve for an initial acceleration of two miles per hour per second on a tangent level track.

18. If the schedule speed of the train in the foregoing problem is 25 miles per hour and the rate of braking is $2\frac{1}{2}$ miles per hour per second, complete the speed time curve of problem 17 for a run of $1\frac{1}{4}$ miles, allowing a ten-second stop.

CHAPTER V.

RAILWAY MOTOR CONTROL.

27. Direct-current Control. — The motor-control equipment of an electric car or train serves to regulate the speed and direction of rotation of the motors and to govern their action during periods of initial acceleration. The most important function of a railway motor controller is to maintain a sufficiently uniform change of velocity during initial acceleration, due consideration being given to the durability of the apparatus and to the comfort of passengers. Thus the variations in the starting current from the average value necessary to produce the required tractive effort for the specified rate of acceleration must be so restricted that the accompanying fluctuations in torque will not be injurious to the equipment or unpleasant for the passengers, and the maximum current attained will not give rise to commutation difficulties.

With direct-current series motors two general methods of control are in use: 1, rheostatic control, and 2, series-parallel control.

28. Rheostatic Method. — In the rheostatic method, for use with one or more motors, resistance is connected in series with the motor circuits, which is varied so as to regulate the voltage impressed upon the motors. A scheme of connection for a rheostatic railway controller is indicated in Fig. 34. Successive portions of this resistance are short-circuited by closing switches 1, 2, 3, and 4

in the order named, thus gradually increasing the pressure applied to the motor terminals. This method, although simple, is infrequently employed because the loss in the regulating resistance is not conducive to economical operation.

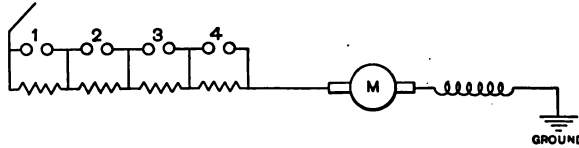

Fig. 34.

29. Series-parallel Method. — The series-parallel method of railway motor control is extensively used for equipments with two (or any multiple of two) motors. The car is started from rest and accelerated by first placing the two motors and a resistance in series and then cutting out the resistance step by step until the motors are operating in series on full voltage. Since with all the resistance cut out there is no unnecessary I^2R loss, this is called a running connection, and the controlling mechanism is said to be on a running point. To increase the speed further, the motors are placed in parallel, with a resistance in series with both. This resistance is then cut out step by step until the motors are each operating on the full line voltage. This also constitutes a running connection.

The circuits of a series-parallel controller are more complex than those of the rheostatic type, since additional connections are required to effect the transition from the series to the parallel position. For accomplishing this change three different methods may be used. Their distinctive features are respectively (1) the shunting or short-circuiting of one of the motors; (2) the opening of the power

circuit; (3) the maintenance of full current through all motors during transition.

Most of the so-called Type K controllers, ordinarily used with single-car equipments, operate according to the first method, the successive steps of which are essentially as follows: the starting resistance is gradually cut out until the motors operate in series on full line voltage; thereafter a portion of the total starting resistance is reinserted in series with the two motors, one of which is then shunted or short-circuited, thus connecting the other motor across full voltage but with a protective resistance in circuit. The short-circuited motor is thereafter connected in parallel with the other, the resistance now being in series with both motors; this resistance is subsequently cut out in successive steps.

The second method of series-parallel control, that of opening the power circuit during transition, exemplified by Type L controllers, is merely an extension of the first, intended for use with motors of very large capacity. This method is now rarely employed because of its inferiority to the third method, which has been developed to meet the same requirements more effectively.

The third method of transfer from the series to the parallel position is used with multiple-unit control, and also applied to a few Type K controllers designed to meet the exacting conditions associated with large motor capacity and high voltage. During transition, full current is maintained through all the motors by means of a "bridge" connection. A scheme of connections illustrating this type of series-parallel control is shown in Fig. 35. The controller performs the following operations: switches *A* and *B* are closed, thus placing both motors and all the

resistance in series between the trolley or third rail and ground. This connection, which corresponds to a slow speed that is suitable for switching in terminal yards, is passed over quickly when accelerating at the usual rate. The first movement of the controller handle accomplishes the simultaneous closing of switches 5, 6, and 7. Switches 1 to 4 are then closed consecutively, followed by the closing of switch *C* and the subsequent opening of switches 2 to 7 and *B*, thus connecting the motors in series across the line

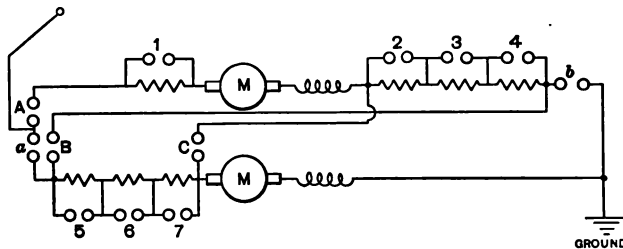

Fig. 35.

through the “bridging” switch *C*. Thereafter switches *a* and *b* are closed. Thus two currents will flow through switch *C* in opposite directions, one from the trolley through the motors to ground and the other through the resistance to ground. With properly proportioned resistances practically no current will pass through *C*, and consequently this “bridging” switch may be opened, thereby placing the motors in parallel, with resistance in series with each. After this, switches 2 and 5, 3 and 6, and 4 and 7 are closed progressively, thus finally placing each motor on full voltage. This method is desirable in that no motor is subjected to a sudden increase in voltage nor is the circuit opened at any time. Unnecessary variations in torque are therefore avoided.

When four motors are installed on a car, they may first be connected in series, then each pair in parallel with the two groups in series, and finally all connected in parallel; this is known as the series, series-parallel, parallel method. Usually, however, the motors are arranged in two groups, each consisting of two motors permanently connected in parallel and treated as a single unit in so far as their control is concerned.

30. Starting Resistances. — The design of starting resistances for use with railway controllers requires a knowledge of the allowable variation in torque during acceleration. When a motor is started from rest with resistance in series, the current gradually decreases with increase in speed because of the generation of more and more counter *E.M.F.*, until a portion of the resistance is cut out, causing a sudden increase in current. Thereafter the current gradually decreases again with further increase in speed until another portion of the resistance is cut out, which causes a sudden rise in current as before. This current fluctuation continues until full line voltage is applied to the motor terminals. These current variations produce corresponding variations in torque, which, if violent, cause unevenness in the velocity increase of the car, resulting in discomfort to passengers and in severe mechanical stresses on the apparatus. Experience shows that, in general, the maximum and minimum values of torque should not differ from the average value required to produce the prescribed acceleration by more than ten per cent of such average value. Since the iron of a direct-current series motor approaches saturation when taking the large current required for starting, the torque exerted is approximately proportional to the current. Hence the current is restricted to a similar range of variation.

Fluctuations in the current supplied to a series motor affect its field strength and thus produce changes in the counter electromotive force generated, which must be considered in designing the controller resistances. The necessary information relative to these changes of counter *E.M.F.* is obtained from the saturation curve of the motor, a curve which shows the electromotive force generated in the armature as a function of the field (or armature) current when the machine is driven at constant speed. This curve is readily computed from the resistance of the motor and its characteristic curves. The electromotive forces corresponding to any given values of current evidently bear the same relation to each other whatever that constant speed may be.

Rheostatic Controllers. The proper resistance units for a rheostatic railway controller may be determined as follows:

Let E = line voltage,

R_m = resistance of motor,

$r_1, r_2, r_3, \dots, r_n$ = the respective controller resistances in series with the motor when the controller arm is on contact studs 1, 2, 3, \dots , n , Fig. 36.

E_2, E_3, \dots, E_n = the respective counter electromotive forces generated at the instants when the arm makes contact with studs 2, 3, 4, \dots , n ,

E'_1, E'_2, \dots, E'_n = the respective counter electromotive forces generated at the instants when the arm breaks contact with studs 1, 2, 3, \dots , n ,

I = average current necessary to produce the required tractive effort for the prescribed rate of acceleration,

I_{\max} = maximum current value and I_{\min} = minimum current value as dictated by the allowable range of current variation,

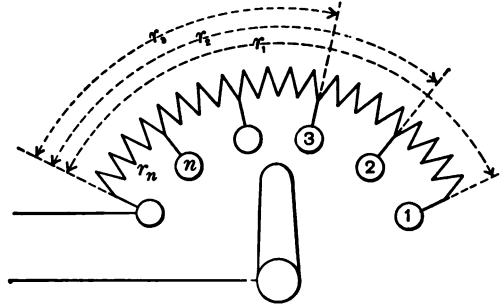

Fig. 36.

E_{\max} = the electromotive force corresponding to the current I_{\max} as determined from the saturation curve, Fig. 37,

E_{\min} = the electromotive force corresponding to the current I_{\min} , Fig. 37,

and for convenience let

$$q = \frac{E_{\max}}{E_{\min}}$$

and

$$K = \frac{I_{\min}}{I_{\max}}.$$

At the instant when the arm touches stud 1, the resistance r_1 should be such that the current flowing through the motor will not exceed I_{\max} ; then

$$I_{\max} = \frac{E}{r_1 + R_m}, \quad (1)$$

whence the total resistance of the rheostat is

$$r_1 = \frac{E}{I_{\max}} - R_m. \quad (2)$$

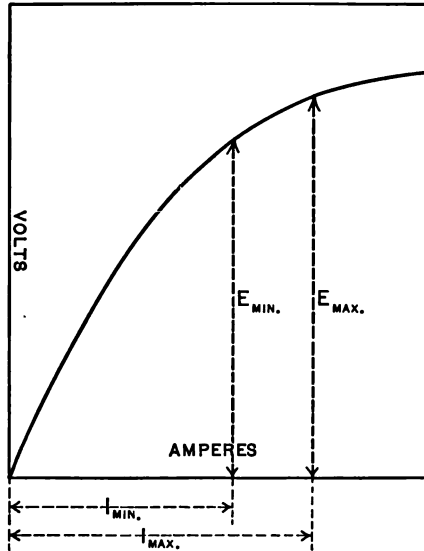

Fig. 37.

As the motor starts from rest and accelerates, the current gradually decreases, and at the instant when it reaches the value I_{\min} the arm should leave stud 1; then

$$I_{\min} = \frac{E - E_1'}{r_1 + R_m}. \quad (3)$$

Dividing (3) by (1) there results

$$K = \frac{E - E_1'}{E},$$

which when solved for E_1' gives

$$E_1' = E(1 - K). \quad (4)$$

At the instant when the arm touches stud 2 the motor current should again be I_{\max} , which is now equal to

$$I_{\max} = \frac{E - E_2}{r_2 + R_m}, \quad (5)$$

whence

$$r_2 = \frac{E}{I_{\max}} - R_m - \frac{E_2}{I_{\max}}. \quad (6)$$

Since E_2 and E_1' are generated at the same speed and with the respective field currents I_{\max} and I_{\min} , reference to the saturation curve shows that

$$\frac{E_2}{E_1'} = \frac{E_{\max}}{E_{\min}} = q,$$

and therefore

$$E_2 = qE_1',$$

which, by substitution from (4), becomes

$$E_2 = Eq(1 - K). \quad (7)$$

At the instant when the current has again decreased to I_{\min} the arm leaves stud 2 and

$$I_{\min} = \frac{E - E_2'}{r_2 + R_m}. \quad (8)$$

Dividing (8) by (5),

$$K = \frac{E - E_2'}{E - E_2},$$

from which

$$E_2' = E(1 - K) + KE_2,$$

whence by substitution from (7)

$$E_2' = E(1 - K) + EqK(1 - K). \quad (9)$$

Proceeding in a similar manner there results

$$r_3 = \frac{E}{I_{\max}} - R_m - \frac{E_3}{I_{\max}}, \quad (10)$$

$$E_3 = qE_2' = Eq(1 - K) + Eq^2K(1 - K), \quad (11)$$

$$E_3' = E(1 - K) + KE_3 = E(1 - K) + EqK(1 - K) + Eq^2K^2(1 - K), \quad (12)$$

and so on.

The resistance of each of the various steps may now be determined; thus, subtracting (6) from (2) and substituting from (7), the portion between studs 1 and 2 is

$$r_1 - r_2 = \frac{E_2}{I_{\max}} = \frac{E}{I_{\max}} q(1 - K). \quad (13)$$

Similarly,

$$r_2 - r_3 = \frac{1}{I_{\max}}(E_3 - E_2) = \frac{Eq^2K}{I_{\max}}(1 - K) = qK(r_1 - r_2), \quad (14)$$

$$r_3 - r_4 = \frac{1}{I_{\max}}(E_4 - E_3) = \frac{Eq^3K^2}{I_{\max}}(1 - K) = qK(r_2 - r_3), \quad (15)$$

and so on.

An expression for the total number of steps required may be derived, but it is more convenient to proceed by first determining the total resistance by equation (2), then computing successive steps by equations (13), (14), etc., until the sum of the resistance steps thus obtained is approximately equal to (preferably equal to or greater than) the total resistance. This determines the number of steps into which the total resistance is to be divided.

The foregoing equations may be used in designing the starting resistances of rheostatic controllers for any number of motors, connected in any way, provided appropriate values are substituted for I_{\max} and R_m . The same expressions may also be employed for calculating the series resistance steps of series-parallel controllers.

Series-Parallel Controllers. The design of the parallel resistance steps for series-parallel controllers involves a de-

termination of the proper resistances to be connected in series with a motor (or motors) already in operation and therefore generating a definite counter electromotive force. This is a more general problem of which the preceding derivation is a particular case. Thus, if the controller shown in Fig. 36 is to be placed in series with a motor that has already attained some definite speed because of its previous operation in series with another motor, the equations governing the design of the rheostat must be modified as follows.

At the instant when the lever arm touches stud 1 the current flowing is

$$I_{\max} = \frac{E - E_1}{r_1 + R_m}, \quad (16)$$

where E_1 is the counter electromotive force that is being generated at this instant. The other symbols retain their former significance. Herefrom

$$r_1 = \frac{E}{I_{\max}} - R_m - \frac{E_1}{I_{\max}}. \quad (17)$$

At the instant when the arm leaves stud 1 the current flowing should be as before,

$$I_{\min} = \frac{E - E_1'}{r_1 + R_m}. \quad (18)$$

Dividing (18) by (16) and solving for E_1' there results

$$E_1' = E(1 - K) + KE_1. \quad (19)$$

Again, at the instant when the arm touches stud 2 the current should again be

$$I_{\max} = \frac{E - E_2}{r_2 + R_m}, \quad (20)$$

consequently

$$r_2 = \frac{E}{I_{\max}} - R_m - \frac{E_2}{I_{\max}}. \quad (21)$$

As before, $E_2 = qE_1'$,

whence by substitution from (19)

$$E_2 = Eq(1 - K) + qKE_1. \quad (22)$$

The instant the arm leaves stud 2 the current diminishes to

$$I_{\min} = \frac{E - E_2'}{r_2 + R_m}. \quad (23)$$

Dividing (23) by (20) and solving for E_2' ,

$$E_2' = E(1 - K) + EqK(1 - K) + qK^2E_1. \quad (24)$$

Herefrom

$$r_3 = \frac{E}{I_{\max}} - R_m - \frac{E_3}{I_{\max}} \quad (25)$$

and

$$E_3 = qE_2' = Eq(1 - K) + Eq^2K(1 - K) + q^2K^2E_1, \quad (26)$$

and so on.

Proceeding exactly as in the foregoing derivation there are obtained the following expressions for the resistances of the various steps of the controller:

$$r_1 - r_2 = \frac{I}{I_{\max}}(E_2 - E_1) = \frac{Eq}{I_{\max}}(1 - K) - \frac{E_1}{I_{\max}}(1 - qK), \quad (27)$$

$$r_2 - r_3 = \frac{I}{I_{\max}}(E_3 - E_2) = qK(r_1 - r_2), \quad (28)$$

$$r_3 - r_4 = \frac{I}{I_{\max}}(E_4 - E_3) = qK(r_2 - r_3), \quad (29)$$

and so on.

If the controller having the resistance steps under consideration is to be used in starting a motor (or motors) from rest, E_1 is equal to zero and the equations reduce to the forms previously derived. If, however, the motor is already in operation, E_1 will have some value greater than

zero. In calculating the parallel resistance steps of a series-parallel controller, this value may be determined from the fact that the total resistance for parallel operation should be of such magnitude as to allow the current to increase from I_{\min} to I_{\max} when the motors are transferred from the series to the parallel connection. Herefrom it follows that

$$E_1 = qE_s,$$

where E_s is the counter *E.M.F.* per motor at the instant when the series connection is interrupted. Since the total counter *E.M.F.* generated when the motors are running in series without resistance is equal to the line voltage minus the total resistance drop, the value of E_s may readily be obtained in any given case. Thus, for a two-motor equipment

$$E_1 = qE_s = q \frac{(E - 2 R_m I_{\min})}{2}. \quad (30)$$

A definite knowledge of the resistance of the motor connections and car wiring is conducive to even greater accu-



Fig 39.

racy in the determination of the controller resistance units.

A three-point grid resistance manufactured by the Westinghouse Electric Company is shown in Fig. 38.

31. Numerical Example.—As an illustration of the method of applying the foregoing equations to the calculation of resistance steps, consider the design of a series-parallel drum-type controller for use on a car equipped with two 35-horsepower, 500-volt motors. The saturation curve of the motors is shown in Fig. 39, and the resistance

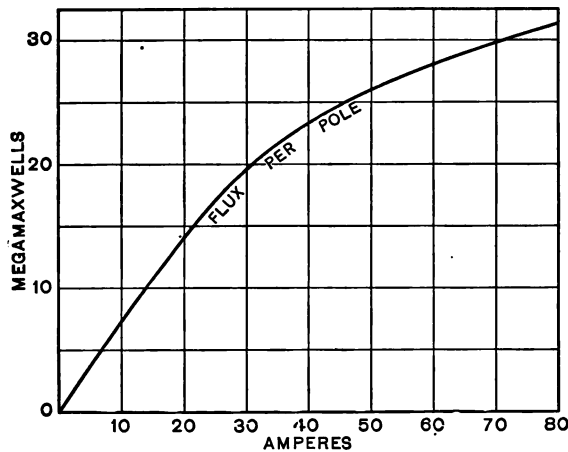

Fig. 39.

of each motor is 1.18 ohms. The operating conditions are such that an average starting current of 60 amperes per motor is necessary to produce the prescribed initial acceleration rate, and the controller specifications require that the limiting values of current shall not differ from this average value of 60 amperes by more than 10%.

In this problem

$$I_{\max} = 60 \times 1.1 = 66 \text{ amperes,}$$

$$I_{\min} = 60 \times 0.9 = 54 \text{ amperes,}$$

and therefore

$$K = \frac{54}{66} = 0.818, \quad q = \frac{2.92}{2.66} = 1.10,$$

and $qK = 1.1 \times 0.818 = 0.90$.

The total starting resistance required for the operation of the two motors in series is

$$r_1 = \frac{500}{66} - 2 \times 1.18 = 7.58 - 2.36 = 5.22 \text{ ohms,}$$

and the various series resistance steps into which it is divided are:

$$r_1 - r_2 = \frac{500 \times 1.1}{66} (1 - 0.818) = 1.52 \text{ ohms,}$$

$$r_2 - r_3 = 0.9 \times 1.52 = 1.37 \text{ ohms,}$$

$$r_3 - r_4 = 0.9 \times 1.37 = 1.23 \text{ ohms,}$$

and

$$r_4 - r_6 = 0.9 \times 1.23 = 1.11 \text{ ohms,}$$

making a total of 5.23 ohms.

The counter *E.M.F.* generated at the instant when the motors are placed in parallel is

$$E_1 = \frac{1.1 (500 - 2 \times 1.18 \times 54)}{2} = 205 \text{ volts.}$$

Hence the total resistance required for parallel operation is

$$r_1 = \frac{500}{66 \times 2} - \frac{1.18}{2} - \frac{205}{66 \times 2} = 3.79 - (0.59 + 1.55) = 1.65 \text{ ohms,}$$

and the various parallel resistance steps into which it should be divided are:

$$r_1 - r_2 = \frac{500 \times 1.1}{66 \times 2} (1 - 0.818) - \frac{205}{66 \times 2} (1 - 0.9)$$

$$= 0.758 - 0.155 = 0.603 \text{ ohms,}$$

$$r_2 - r_3 = 0.9 \times 0.603 = 0.543 \text{ ohms,}$$

and

$$r_3 - r_4 = 0.9 \times 0.543 = 0.489 \text{ ohms,}$$

constituting a total of 1.635 ohms.

32. Field Control. — With commutating-pole direct-current railway motors additional running speeds may be obtained by varying the number of turns on the main field without introducing commutation difficulties. Motors utilizing this method, called *field-control motors*, have more field turns than they would otherwise and have their field windings divided into two parts, so that both parts may be connected in series to secure high torque during starting and only one part is used during operation at high speed. The benefits derived in using such motors are the lowering of the starting current and the reduction of energy loss during the starting period.

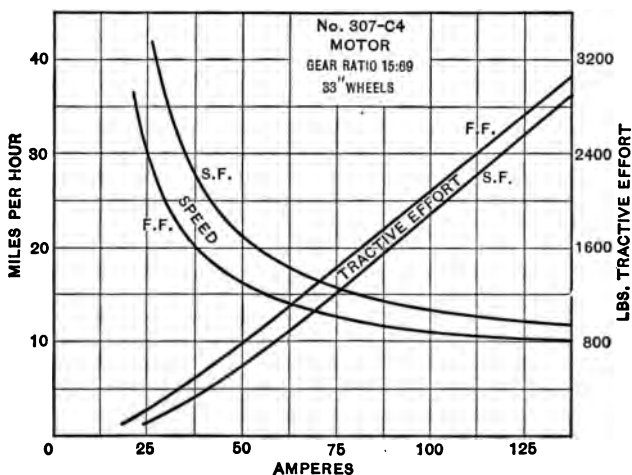

Fig. 40.

Fig. 40 shows the tractive effort and speed curves of a 50-horsepower, 600-volt Westinghouse field-control motor

for full field (F.F.) and short field (S.F.) conditions. If a car requires each motor to exert a tractive effort of 1600 pounds at starting, the motor will take 81 amperes on full field until a speed of 12.4 miles per hour is reached. Then if the short-field connection is made this same tractive effort would demand 90 amperes until a speed of 14.2 miles per hour is attained. Thus the motor without field control (that is, the equivalent of short-field connection) would take 90 amperes for the starting time from 0 to 14.2 miles per hour, whereas the field-control motor would only take 81 amperes for 7/8 of that starting time. In consequence less energy is taken with such motors than with others of equivalent rating, the saving in energy having been found to be from 5 to 15 per cent in various service tests.

33. Alternating-current Control. — Single-phase series motors in railway service are controlled, like direct-current motors of the series type, by varying the pressure applied to their terminals. This variation may be effected by the standard direct-current method previously described. More efficient means of potential regulation are, however, available with alternating current, so that the large I^2R loss incident to the use of starting resistances may be avoided and a greater number of running points obtained. Two general methods of control peculiar to alternating currents are at present employed with single-phase equipments: 1, the induction regulator, and 2, the compensator method.

Induction Regulators. — In starting a car or train by the former method the voltage impressed upon the motor terminals is gradually increased by means of a single-phase induction regulator. This device is essentially a transformer of which one coil is movable with respect to the other, the windings being arranged in a manner similar

to those of a coil-wound induction motor. The primary coil is usually connected to suitable taps on an autotransformer or compensator, used to step down the voltage. The secondary coil is placed in series with the motor circuit, which is likewise connected to transformer taps of suitable potential. By changing the relative position of the regulator coils the effective *E.M.F.* induced in the secondary winding of the regulator may be varied from zero to a definite maximum value in either direction, that is, in phase with or in phase opposition to the *E.M.F.* impressed upon the motor circuit by means of the transformer. Thus, if E_1 is the *E.M.F.* between the transformer

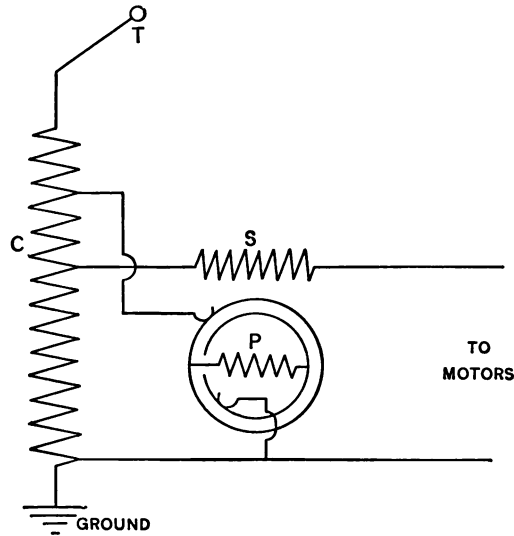

Fig. 41.

taps to which the motor circuit is connected, and E_r is the maximum *E.M.F.* induced in the secondary coil of the regulator, then, neglecting the impedance drop in the wiring, the pressure applied to the motors may be varied

through all values from $E_t - E_r$ to $E_t + E_r$, according to the cosine of the angle of displacement between the axes of the two windings. This method of control is illustrated by the scheme of connections shown in Fig. 41, where C is the autotransformer which is connected across the line, S is the secondary coil of the induction regulator and is in series with the motor circuit, and P is the primary coil thereof, which in this case is the movable element of the regulator. Evidently every possible position of the controller will result in a definite voltage upon the motors, so this

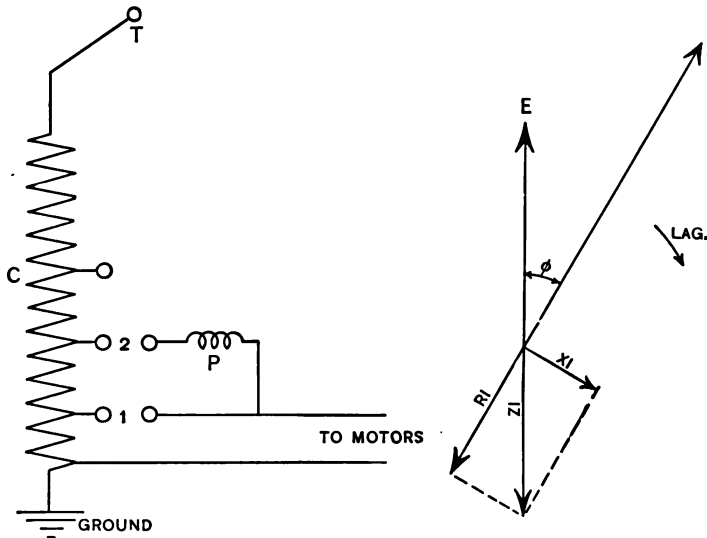

Fig. 42.

method of control yields a multiplicity of running positions. The large weight and low power factor of the regulators, and

the complicated mechanism required for their operation are, however, serious objections which tend to retard the further adoption of this type of control.

34. Compensators.— In the compensator method of control the voltage at the motors is regulated by varying the ratio of transformation of a compensator, which serves also as a step-down transformer in those installations where high trolley potentials are used. One terminal of the motor circuit is connected to ground. The other terminal may be successively connected to a series of compensator taps so arranged that during initial acceleration the *E.M.F.* applied to the motor circuit may be increased in suitable steps until each motor operates on rated voltage.

The connections of a compensator-type controller should be such that the transition from one compensator tap to another may be effected without interrupting the motor current or short-circuiting any portion of the compensator winding. For example, in transferring the motor connection from tap 1 to tap 2 of the compensator *C*, shown in Fig. 42, an uninterrupted flow of current through the motors is maintained by closing switch 2 before switch 1 is opened. In order that this procedure may not short-circuit the portion of the compensator winding included between taps 1 and 2, a *preventive coil P* is connected in series with switch 2 as shown. The resistance *R* and the reactance *X* of this preventive coil are so proportioned that the impedance drop ZI , resulting from the passage of the motor current *I*, is equal in magnitude and opposite in phase to the voltage *E* existing between taps 1 and 2 of the compensator winding. This relation is indicated by the vector diagram in Fig. 42, where ϕ is the angle by which

the motor current lags behind the pressure E , which is of course in phase with the voltage impressed upon the motor circuit by means of the compensator. It is evident from this figure that the values of resistance and reactance required depend on the power factor, $\cos \phi$, of the motor circuit. Since the power factor varies through a considerable range during the period of uniform acceleration, it is desirable to connect in series with each compensator switch a preventive coil designed to meet the particular conditions obtaining at the instant when that switch is closed. This method of control has, however, the disadvantage of requiring a relatively large number of preventive coils no two of which have the same constants, yet each must be designed to carry the full motor current.

In the so-called *multiple-switch* method of compensator control, now extensively employed, the preventive coils are used as auto-transformers to divide the motor current between two or more compensator switches. Thus, at each running point of the controller the motor circuit is connected to a set of two or more successive compensator taps, each of which supplies a definite fractional part of the motor current. The essential features of this method are illustrated in Fig. 43. In the particular scheme of connections there depicted, three preventive coils are used to divide the motor current into four approximately equal parts. The first running position of the controller is attained by closing switches 1, 2, 3, and 4. The voltage applied to the motor circuit when the controller is in this position is evidently equal to the potential relative to ground of a point on the compensator winding midway between taps 1 and 4. When the controller handle is moved to the second running position switch 1 is opened,

followed by the closing of switch 5. Similarly, to pass to the third running point, switch 2 is opened and then switch 6 is closed; and so on until the motors are supplied with current at rated voltage through switches 5, 6, 7, and 8. It is obvious that during transition from one running point

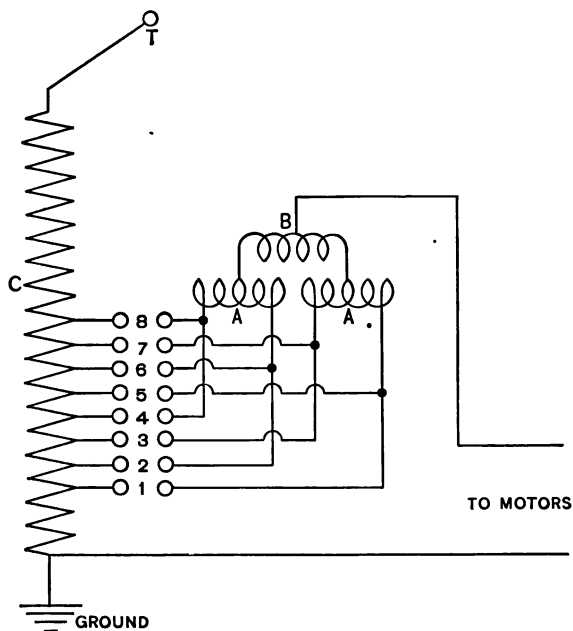

Fig. 43.

to another the full motor current is maintained without short-circuiting any portion of the compensator winding. Since each switch is required to handle only a fractional part of the total current supplied to the motor circuit, this method is well suited for use with railway equipments of large capacity.

In cases where single-phase series motors are required to

operate on direct current over a portion of the roadway, some form of rheostatic or series-parallel control must be installed for use during the periods of direct-current operation. The losses that would result from the use of starting resistances during the intervals of alternating-current operation are, however, in general sufficient to justify the installation of compensator control for use on the sections where alternating current is employed. This compensator may constitute a part of the autotransformer which is used to step down the high trolley voltage associated with alternating-current traction to a lower value which is suitable for motor operation. The use of compensator control on road sections supplied with alternating current therefore involves little additional expense.

35. Induction Motor Control. — The methods of control required with three-phase induction motors are essentially different from those employed with alternating-current railway motors of the series type. The latter methods are not applicable to induction motors in railway service, since the reduction in impressed voltage necessary in starting by any of these methods causes a prohibitive decrease in the capacity of such machines. The following methods are, however, available for the control of three-phase induction motor equipments: (a) variable resistances in the secondary circuits of the motors; (b) changing the number of poles of the motors; (c) cascade operation of the motors.

(a) *Variable Resistance Method.* The insertion of variable external resistances in series with each phase of the secondary windings of the motors by means of suitable slip rings constitutes the principal method of maintaining an approximately uniform torque during the periods of initial acceleration. These resistances are so proportioned

that the motor exerts at starting a torque sufficient for the prescribed acceleration rate. As the speed of the motor increases, causing a decrease in the *E.M.F.* induced in the rotor windings, the external resistances are cut out successively, thereby maintaining a moderately constant secondary current and thus uniformly increasing the speed at which the motor exerts the definite torque required. While this method possesses the advantage of simplicity, it does not permit of efficient acceleration because of the I^2R losses in the rotor resistances. It also provides for only one efficient running speed, since the induction motor is practically a constant-speed machine, the slip rarely exceeding 10% of the synchronous speed which the motor closely approaches when the car runs at its ultimate velocity on a level roadway. It is therefore desirable to employ in connection with this resistance method of control some means of changing the synchronous speed of the motors, thereby reducing the I^2R losses during acceleration and providing for one or more additional running speeds.

(b) *Variable Multipolarity Method.* In the second method of control the synchronous speed of the motors is varied by changing the number of motor field poles. If the frequency of the voltage be f cycles per second, the synchronous speed in revolutions per minute is

$$V_m = \frac{60f}{p},$$

where p is the number of pairs of poles on the induction motor.

In order to change the number of poles of a given induction motor it is necessary either to provide two or more separate windings, each of which is designed to yield a

different number of poles, or to employ a single winding so arranged that the number of poles which it produces may be altered by a suitable change in the connections between the various parts of the winding and the three-phase line. The latter method is the more desirable since no inductors are idle during operation.

A simple arrangement of windings for carrying out this method is illustrated in Fig. 44, which shows the stator winding of one phase of an 8-pole — 4-pole, three-phase induction motor. The complete phase winding 1-3 is divided

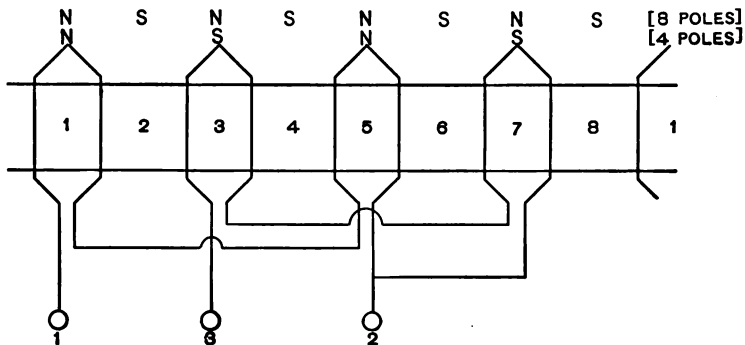

Fig. 44.

into the two parts 1-2 and 2-3 by a tap 2 at the middle point of the winding. Terminals 1 and 3 connect with the windings of the two other phases, which for clearness are not shown in this figure. The winding shown in Fig. 44 differs from the usual induction motor winding in that only alternate poles are wound. To produce an 8-pole magnetic field the windings 2-1 and 2-3 are placed in parallel with each other by connecting tap 2 to one of the line wires and taps 1 and 3 to the neutral point of the phase windings. The coils are so arranged that when thus connected they pro-

duce poles which are all of the same polarity. Intermediate poles of opposite polarity will therefore be formed between them, thus producing an 8-pole field as indicated.

If, however, a 4-pole field is desired, windings 1-2 and 2-3 are placed in series by connecting terminals 1 and 3 to

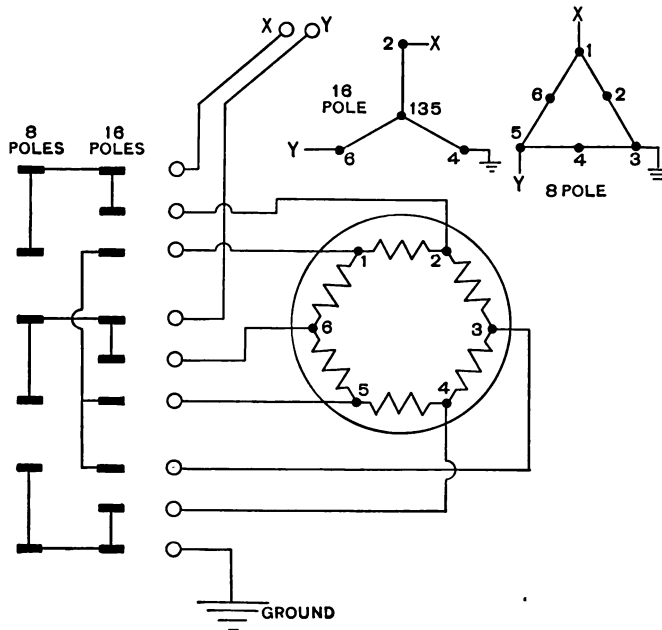

Fig. 45.

line wires of the three-phase supply. One of the windings is thereby reversed with respect to the other and consequently the poles pertaining thereto will be of opposite polarity. The intermediate poles will then disappear, resulting in a 4-pole field. Fig. 45 shows the schematic arrangement and the controller connections for simultaneously changing the number of poles of all three stator phases.

(c) *Cascade Method.* The third method of three-phase induction motor control consists in operating two motors in cascade. In the cascade connection, or *concatenation*, of two induction motors, the rotors of both machines are mounted on the same shaft or otherwise mechanically coupled as by gears or connecting rods. The primary of the first motor is connected to the line and its secondary is connected to the primary of the second motor. The secondary windings of the latter machine are short-circuited through suitable starting resistances.

When two induction motors are started in cascade connection, the power output of the first machine consists in part of mechanical power delivered to the rotor shaft and in part of electrical power supplied to the primary of the second machine. During initial acceleration, the torque exerted by such a cascade set is maintained approximately constant by progressively cutting out the starting resistances. Thereafter the torque decreases with further increase in speed, approaching zero as the slip of the second motor decreases toward zero. Thus two motors connected in cascade approach, when operating under light loads, a definite limiting speed, which may be determined as follows:

Let f = the frequency of the line *E.M.F.*,

V_1 = the synchronous speed of the first motor in rev. per min.,

V_2 = the synchronous speed of the second motor in rev. per min.,

V = speed of rotor shaft in rev. per min.,

p_1 = number of pairs of poles of the first motor,

p_2 = number of pairs of poles of the second motor,

s_1 = slip of the first motor,

s_2 = slip of the second motor.

Then

$$V_1 = \frac{60f}{p_1} \quad (1)$$

and

$$V_2 = \frac{60s_1f}{p_2} = \frac{60f}{p_2} \left(\frac{V_1 - V}{V_1} \right) = \frac{60f}{p_2} \left(1 - \frac{V}{V_1} \right),$$

which by substitution from equation (1) becomes

$$V_2 = \frac{60f - p_1V}{p_2}. \quad (2)$$

Since

$$s_2 = \frac{V_2 - V}{V_2},$$

therefore

$$V = V_2(1 - s_2). \quad (3)$$

Substituting in equation (3) the value of V_2 given in equation (2), there results

$$V = \frac{60f - p_1V}{p_2}(1 - s_2), \quad (4)$$

which shows that as s_2 approaches zero V approaches the limiting speed,

$$\frac{60f}{p_1 + p_2}.$$

Hence the synchronous speed of the two motors connected in direct concatenation is the same as that of a single motor having $p_1 + p_2$ pairs of poles.

Two similar induction motors connected in cascade share the load with approximate equality; thus the second motor utilizes a considerable portion of the energy that would otherwise be consumed in the starting resistances when operating at speeds below the synchronous speed of the combination. At the latter speed, however, the torque exerted is zero, and with further increase in speed, such as

(c) *Cascade Method.* The third method of three-phase induction motor control consists in operating two motors in cascade. In the cascade connection, or *concatenation*, of two induction motors, the rotors of both machines are mounted on the same shaft or otherwise mechanically coupled as by gears or connecting rods. The primary of the first motor is connected to the line and its secondary is connected to the primary of the second motor. The secondary windings of the latter machine are short-circuited through suitable starting resistances.

When two induction motors are started in cascade connection, the power output of the first machine consists in part of mechanical power delivered to the rotor shaft and in part of electrical power supplied to the primary of the second machine. During initial acceleration, the torque exerted by such a cascade set is maintained approximately constant by progressively cutting out the starting resistances. Thereafter the torque decreases with further increase in speed, approaching zero as the slip of the second motor decreases toward zero. Thus two motors connected in cascade approach, when operating under light loads, a definite limiting speed, which may be determined as follows:

Let f = the frequency of the line *E.M.F.*,

V_1 = the synchronous speed of the first motor in rev. per min.,

V_2 = the synchronous speed of the second motor in rev. per min.,

V = speed of rotor shaft in rev. per min.,

p_1 = number of pairs of poles of the first motor,

p_2 = number of pairs of poles of the second motor,

s_1 = slip of the first motor,

s_2 = slip of the second motor.

Then

$$V_1 = \frac{60f}{p_1} \quad (1)$$

and

$$V_2 = \frac{60s_1f}{p_2} = \frac{60f}{p_2} \left(\frac{V_1 - V}{V_1} \right) = \frac{60f}{p_2} \left(1 - \frac{V}{V_1} \right),$$

which by substitution from equation (1) becomes

$$V_2 = \frac{60f - p_1V}{p_2}. \quad (2)$$

Since

$$s_2 = \frac{V_2 - V}{V_2},$$

therefore

$$V = V_2(1 - s_2). \quad (3)$$

Substituting in equation (3) the value of V_2 given in equation (2), there results

$$V = \frac{60f - p_1V}{p_2}(1 - s_2), \quad (4)$$

which shows that as s_2 approaches zero V approaches the limiting speed,

$$\frac{60f}{p_1 + p_2}.$$

Hence the synchronous speed of the two motors connected in direct concatenation is the same as that of a single motor having $p_1 + p_2$ pairs of poles.

Two similar induction motors connected in cascade share the load with approximate equality; thus the second motor utilizes a considerable portion of the energy that would otherwise be consumed in the starting resistances when operating at speeds below the synchronous speed of the combination. At the latter speed, however, the torque exerted is zero, and with further increase in speed, such as

occasioned by running down grades, the torque becomes negative and the cascade set operates as a generator, returning energy to the line.

In most cases of cascade control the motors are divided into groups, each of which consists of a main motor and an auxiliary motor, the latter being employed during cascade

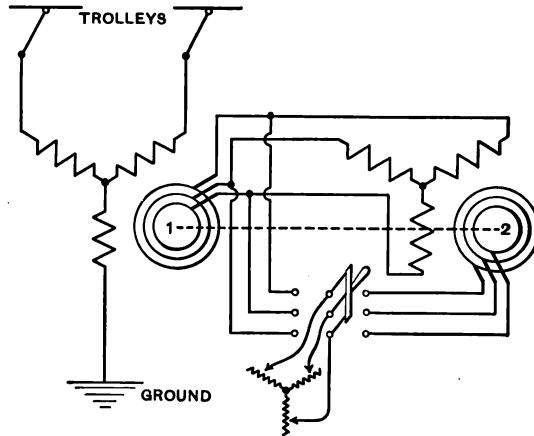

Fig. 46.

operation only. In starting, each auxiliary motor is connected in cascade with the corresponding main motor, and the starting resistances in the secondary circuits of the former are cut out in successive steps. The cascade connection is then broken by short-circuiting the secondary windings of the main motor through the starting resistances, which are thereafter cut out progressively as before. Thus the auxiliary motors are required to operate only intermittently on a low voltage, and the full-speed power factor of the main motors is higher than would be the case if their load were shared with the auxiliary motors by connecting the latter across the line. Fig. 46 shows a scheme of connections for this method of control.

36. Controllers. — All types of railway motor control must include means for changing the direction of rotation of the motors. A series motor is reversed by interchanging the connections of either its field or its armature windings. The standard method of reversing series motors which have no commutating poles is to reverse the armature, while that of commutating-pole motors is to reverse the main field so that the relative directions of current through the armature and commutating-pole windings will be unchanged. With a three-phase induction motor reversal of direction is obtained by exchanging the connections of any two of the three leads that supply the motor with current.

Hand Control. — The manipulation of the switches is accomplished directly by hand or through the intervention of an auxiliary control. In the former system a motorman makes the necessary electrical connections by moving a handle at the top of a controller on the car platform. The movement of this handle causes the rotation of a vertical cylinder and thus permits of the successive connection of various contact studs thereon with stationary fingers, which, by means of suitable car wiring, are properly connected to the trolley or third rail, to the motors, and to the different rheostat terminals or compensator taps. Fig. 47 shows a Westinghouse controller, for series-parallel operation, with the cover removed. It has seven controlling points in the series position and six in the parallel position, and the motors are short-circuited during the transition period. The direction of rotation of the motors is changed by moving a reversing lever and thus actuating a smaller cylinder which is mounted beside the main cylin-

der of the controller and is provided with suitable contact pieces for effecting the necessary change in connections. Interlocking devices are supplied, so that the reversing handle cannot be moved unless the controlling handle is in such a position that connection with the trolley or third rail is



Fig. 47.

broken. The controlling handle also cannot be moved if the reversing handle is not properly set either for forward or backward motion of the car. The reversing handle can be removed from the controller only when in its neutral or "off" position, to which it cannot be turned unless the controlling handle is also in its "off" position, thus entirely disconnecting the motor circuits from the trolley or third

rail. Cut-out switches are provided, so that a defective motor or group of motors may be disconnected without interfering with the operation of the remaining motor or motors. As serious arcs are liable to ensue upon breaking a circuit of 500 volts, the contact pieces and fingers are separated from adjacent ones by strips of insulating materials, which are usually fastened to the inside of a separate cover. Such arcs are effectively disrupted by the field of an electromagnet, which is an essential part of controllers used with motors of large capacity.

Multiple-Unit Control. — The system of motor control in which the switches are operated electrically or pneumatically through the intervention of an auxiliary circuit is called the *multiple-unit system*, since it is designed for the operation of several motor cars coupled together in a train, all the motors being controlled simultaneously from any master controller on the train. This system is now extensively employed not only for the operation of trains made up of motor cars and trailers but also for the control of electric locomotives and single-car equipments of large capacity. The control apparatus for each motor car or locomotive consists of a motor controller and two master controllers.

The motor controller is composed of a number of switches or contactors, which close and open the various motor, resistance, or compensator circuits, and in general effect the changes in connection necessary in controlling the particular type of motor employed. Each of these contactors opens in a strong magnetic field, so that all arcs are immediately disrupted. A separate reversing switch governs the direction of rotation of the motors. On motor cars all this apparatus is usually placed underneath the car, but on locomotives it is located in the cab. The contac-

tors and reverser may be operated by solenoids or by the use of compressed air controlled by electrically operated valves. In either case the solenoids or other electromagnets that govern the movement of the switches are connected to the wires of the auxiliary circuit and are supplied with current in proper sequence by the hand-operated master controller.

The master controller is considerably smaller than the ordinary street-car controller, but is similar in appearance and method of operation. The contact fingers of each master controller are connected to the wires of the auxiliary or control circuit, which usually consists of a multiple-conductor cable. By means of suitable couplers this control cable is made continuous throughout any number of motor cars or locomotives operated together in a train. Current for the master control is taken from the line, or from a storage battery, through whichever master controller the motorman operates. Since this current is used solely for energizing the operating coils of the motor contactors, its value is comparatively small, usually not exceeding 2.5 amperes for each car equipment. As the operating coils of each motor controller are connected to the wires of the control cable, any master controller on the train will simultaneously operate corresponding contactors on all the motor cars and thus establish similar motor connections on them. To avoid accidents which may occur through the physical disability of a motorman, the operating handle of the master controller is sometimes provided with a button which must be held down in order to keep the auxiliary control circuit closed. In some cases the connections are so arranged that releasing this button applies the air brakes as well as opens the control circuits.

The essential features of the multiple-unit system of control as applied to direct-current equipments are illustrated in Fig. 48, which shows the principal motor and control circuits for one motor car. For clearness the reverser is omitted, as are also the circuits necessary for its control. Assuming therefore that the reverser is properly set, the subsequent operation of the control system during initial acceleration is as follows: turning one of the master controllers to the first notch results in the closing of contac-

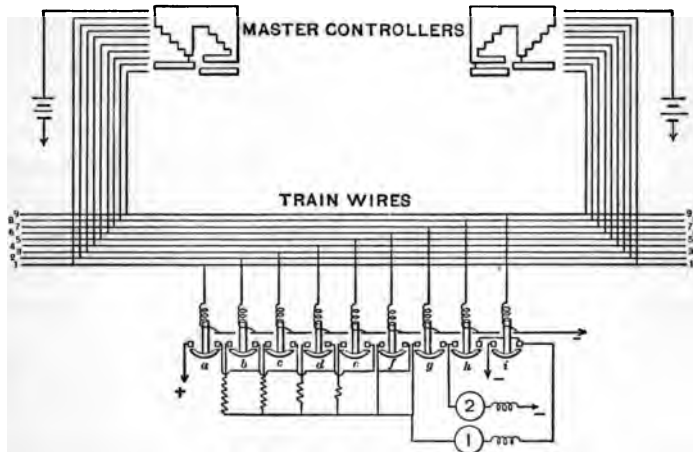

Fig. 48.

tors *a*, *b*, and *h*, due to current received from train wires 1, 2, and 8, thus establishing connection with the line and placing the two motors and a protecting resistance in series. Turning the master-controller handle successively to notches 2, 3, and 4 closes contactors *c*, *d*, and *e*, respectively, thereby progressively reducing the resistance by placing additional resistance units in parallel. When the controller handle is moved to the fifth notch, contactor *f* is closed,

short-circuiting the resistances and connecting the motors in series across the line. In passing over the sixth or transition notch contactors *c* to *f* and *h* are opened, followed by the closing of contactors *g* and *i*. This places the motors in parallel, with resistance in series with both. Turning the master-controller handle successively to notches 7, 8, 9, and 10 progressively reduces the resistance as before until each motor is operating on full line voltage.

The operation of the switches of a multiple-unit equipment in other than their proper sequence is prevented by various interlocking devices. For example, the connections are so arranged that the reverser on a car cannot be actuated save when the contactors on that car are open, nor can the operating coils of the contactors be energized unless the reverser is properly set for the direction of motion indicated by the master controller. By means of a suitable cut-out switch the operating coils of the motor controller on any car can be disconnected from the control circuit without interfering with the operation of the train from either of the master controllers on that car.

In multiple-unit equipments similar to that illustrated in Fig. 48 the progressive closing of the contactors is accomplished by turning the master-controller handle to successive notches. The maintenance of an approximately constant current during initial acceleration is therefore entirely dependent on the motorman's care and skill. It is often desirable to have the progressive operation of the contactors regulated by the motor current itself, in order that the variations in this current from the average value required during acceleration may be automatically restricted to the prescribed range, thereby insuring a uniform rate of acceleration and permitting the motorman to con-

fine his attention to the track and signals. This *automatic* acceleration is effected by means of current-limit relays having coils connected in series with the motor circuit. Such relays may be arranged to regulate the progressive closing of the motor-controller switches in either of two ways: 1, by governing the movement of the master-controller contact cylinder, or 2, by governing the supply of current to the operating coils of the individual contactors.

In the former method the contact cylinder of each master controller is connected to its operating handle through a helical spring. The cylinder is restrained by a magnetic clutch actuated by a current relay in series with the motor circuit. This relay is so adjusted as to release the clutch and allow the contact cylinder to advance one step whenever the motor current falls to its minimum limiting value. The master-controller handle may therefore be turned at once to any desired position, and the contact cylinder will follow in successive steps automatically governed by the motor current of the car on which the motorman is stationed. Evidently this method cannot be expected to give satisfactory results in cases where there is a material difference in the motor characteristics or the current requirements of the various cars composing a train.

In the second method of automatic acceleration each motor car is provided with a current-limit relay that is designed and adjusted with reference to the requirements of that particular car equipment. The motor connection ultimately established on all the motor cars in a train is determined by the position to which the handle of the master controller is turned; but the successive steps necessary to attain this connection are governed independently for each car by the motor current of that car. The connec-

tions between the operating coils of the contactors and the control circuit are made automatically through auxiliary contacts on the contactors themselves; and the control current for closing these switches passes through the contacts of the current-limit relay.

PROBLEMS.

19. Determine the resistance units of a rheostatic railway controller for use with one 35-horsepower, 500-volt, direct-current motor having a resistance of 1.18 ohms. The saturation curve of the motor is shown in Fig. 39. The average current required during initial acceleration is 50 amperes; and the maximum and minimum values of the current must not differ from this average value by more than 9 %.

20. Determine the parallel resistance steps of a series-parallel railway controller for use with two 35-horsepower, 500-volt, direct-current motors, the saturation curves of which are shown in Fig. 39, the resistance of each motor being 1.18 ohms. An average current of 50 amperes per motor is required during uniform acceleration, and the limiting values of current are specified at 45 and 55 amperes.

21. A 220-volt, single-phase motor is to be started by means of an induction regulator with an initial voltage of 150. What are the angular displacements between the two regulator coils if 7 steps were required which yield equal voltage increments on the motor?

22. Determine the resistance and the inductance of a preventive coil to be connected in series with a certain compensator switch in order to effect sparkless transition by the method of control illustrated in Fig. 41. At the instant during acceleration when this particular switch is to be closed the 25-cycle motors have attained a speed such that the power factor of the motor circuit is 53 %. The motor current during the period of initial acceleration is approximately constant at 100 amperes and the *E.M.F.* between adjacent compensator taps is 25 volts.

23. A motor car is equipped with four three-phase, four-pole induction motors arranged in pairs for cascade control. Each main motor has 5 stator slots per pole per phase and 18 conductors per primary slot. Each auxiliary motor has 4 stator slots per pole per phase and 4 conductors per primary slot. Determine the equivalent number of stator conductors per pole when the motors are operating in cascade.

CHAPTER VI.

ENERGY CONSUMPTION.

37. Current Curves. — During the period of initial acceleration of a car the current taken by the direct-current motors is maintained roughly constant by the control equipment, provided no changes of grade or curvature occur during this interval. Thereafter, until the car attains its ultimate uniform velocity on the particular roadway under consideration, the motor current decreases, at first rapidly and later more slowly. The instantaneous values of current from the time all the controller resistance is cut out until the power is shut off may be read directly from the performance curves of the motor, since each motor takes a definite current at the various speed values of the car during this period. A curve showing these instantaneous current values in terms of time over a run is called a *current curve* of the railway motor, and serves as the basis for determining whether the assumed motor for a proposed installation can perform the prescribed service without overheating.

It is usual to construct the curve of current per car rather than the current per motor in determining the energy consumption of a tentative equipment. When starting the car the two motors of a two-motor direct-current equipment are connected in series, or the four motors of a four-motor equipment, arranged for the usual series-parallel control, are connected in two groups joined

in series, each group consisting of two motors connected in parallel. Four-motor equipments adapted for series, series-parallel, parallel control are not frequently employed. Hence from the instant of starting until the controller leaves the series position and connects all the motors in parallel with resistance across line voltage the current per car is equal to the current per motor times one-half the number of motors comprising the car equipment. At the end of this period, that is, when the motors are operating on the series position without resistance, the speed of the car is

$$\frac{\frac{E}{2} - IR}{E - IR} V_1,$$

where E is the line voltage, I is the current traversing the motor and R is its resistance, and V_1 is the car speed when the controller is full "on." It is at this speed that the current per car increases from its former value to the product of the current per motor times the number of motors on the car. While the motors operate on reduced voltage in the parallel position their current intake is constant, but thereafter the current per motor and that per car decrease as dictated by the motor performance curves on full line voltage. When coasting begins the current intake ceases and the current curve drops to zero.

38. Average and Effective Currents. — The *average* current taken by the car over a complete run is based not merely upon the time during which the car receives power for propulsion nor upon the running time, but upon the time of the entire run including stops. This average current is determined by finding the area of the current

curve and dividing it by the time of the run as given by the specified schedule speed.

The current per motor which when flowing continuously will yield the same average copper loss in the windings is called the *effective* motor current and is equal to the square root of the average of the squares of the instantaneous current values. The effective current may be found by squaring a suitable number of values of the motor current and plotting these squared values on the time axis. The square root of the average ordinate of the curve drawn through these points and taken over the total time of run represents the equivalent motor current to which the heating of the machine is proportional.

39. Numerical Example. — As an illustration, consider a car equipped with four 50-horsepower, 600-volt, G.E. 216-A direct-current motors whose characteristic curves are shown in Fig. 23. The speed curve of this car over an 0.8 mile run on a straight level track at a schedule speed of 20 miles per hour is shown in Fig. 31, which permits of a 20-second stop. Determine (1) the average current intake for the car and (2) the effective current per motor.

The current consumed by the motor as the car is accelerated uniformly at 1.5 miles per hour per second from standstill to a speed of 16.9 miles per hour (see page 61) is maintained roughly constant at a mean value of 64 amperes, the time necessary for the acquirement of this speed being 11.3 seconds. The current curve over this period will have a series of peaks occasioned by the variations in voltage which is impressed upon the motors by the controller, but the exact shape of this part of the curve is of no particular consequence, and it may be drawn straight through the mean current value. Taking the

resistance of each motor as 0.30 ohm, the resistance drop thereof is 19.2 volts. Therefore the speed of the car at the instant when the transition from the series to the parallel position is made is

$$\frac{\frac{600}{2} - 19.2}{600 - 19.2} \times 16.9 = 8.2 \text{ miles per hour.}$$

This speed is attained in $\frac{8.2}{1.5} = 5.46$ seconds from the instant of starting. Thus, when the car is in motion for 5.46 seconds the current per car increases from $64 \times \frac{1}{2}$ or 128 amperes to 64×4 or 256 amperes. The latter current value persists for $11.3 - 5.46$ or 5.84 seconds. The current curve for the car before the motors operate on full line voltage is shown by *OABCD* in Fig. 49.

Beyond the point *D* the current curve is entirely dependent upon the motor performance curves, since the current intake per motor at different car speeds is directly obtainable therefrom. The times at which these speeds obtain are given by the speed curve for the run under consideration. Thus the curve of current per car may be plotted in terms of time, as done herewith from the following computations:

Speed of car (miles per hour).	Current per motor (amperes).	Current per car (amperes).	Time of speed acquire- ment (seconds). See table, page 64.
20	48.2	192.8	13.84
22	42.1	168.4	16.26
24	37.4	149.6	19.45
26	33.9	135.6	23.65
28	31.0	124.0	29.22
30	28.4	113.6	36.88
32	26.3	105.2	47.78

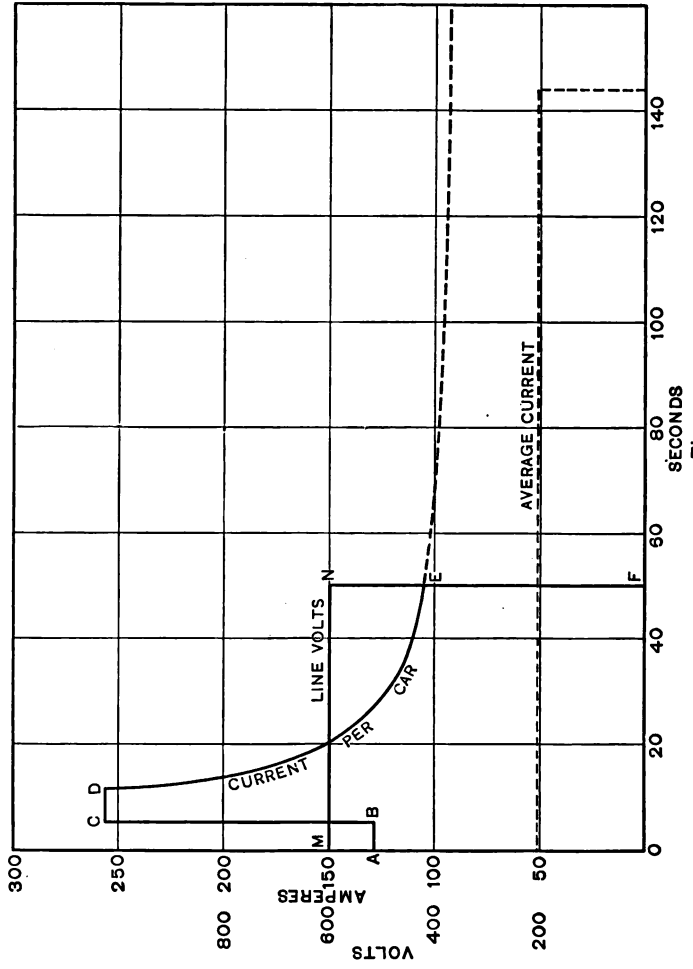

Fig. 49.

After 50 seconds coasting begins and the current curve is completed by drawing the vertical line *EF*.

The area of the current curve per car is 7350 ampere-seconds, which when divided by the time of the run, namely 144 seconds, gives the average current per car over the given run as 51.0 amperes.

The curve of current per motor is shown in Fig. 50, as *OABCD*, the portion *BC* being also plotted from the values recorded in the foregoing table. The ordinates of this curve when squared yield the curve *OEFGD*, the area of which is 90,930 ampere²-seconds. The mean square current over the given run which requires 144 seconds for its completion is 631 (amperes)². Therefore the effective heating current of the motor is 25.1 amperes.

40. Effective Motor Current for a Trip. — The effective motor current for a trip over an entire roadway which is divided into a number of individual runs distributed over several territorial sections on which different service conditions exist is obtained by averaging the squared current values over all the runs and extracting the square root of this average. Thus, for example, if the effective motor current values on typical runs on the city, suburban, and interurban sections of a certain railway are respectively 40 amperes for 25 minutes, 35 amperes for 20 minutes, and 28 amperes for 15 minutes, then the effective current for the entire trip is

$$\begin{aligned} & \sqrt{\frac{(40^2 \times 25) + (35^2 \times 20) + (28^2 \times 15)}{25 + 20 + 15}} \\ &= \sqrt{\frac{40,000 + 24,500 + 11,760}{60}} = 35.6, \end{aligned}$$

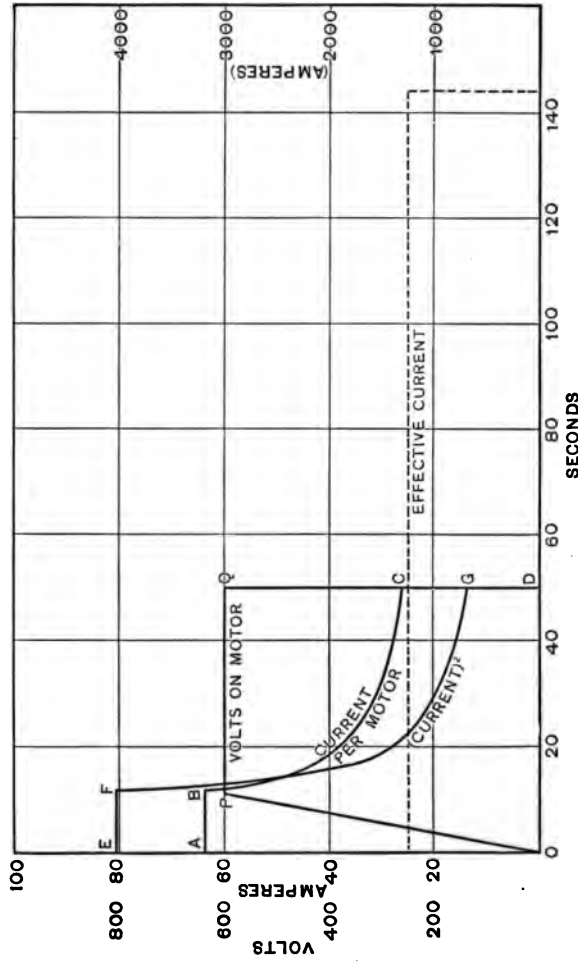

Fig. 50.

since this current flowing for 60 minutes would produce the same heating of the motor as is developed under the actual service conditions.

41. Voltage Curve. — The line voltage in calculations of motor capacity is assumed constant and to have the same value everywhere on the roadway. The voltage on the motor equipment is thus considered constant, and a voltage curve would be a straight horizontal line, as *OMNF* in Fig. 49. The voltage impressed upon the motor terminals during the period of initial acceleration is increased from zero to full line voltage in steps by means of the controller. As a rule there are more than seven such steps, the usual minimum representing four series resistance steps and three parallel resistance steps in the control apparatus. The actual voltage variations are of no consequence, and the voltage per motor may with sufficient accuracy be considered as uniformly increased from zero to its final value. The motor voltage would then be represented by a curve as *OPQD* in Fig. 50, the point *P* indicating the time when the controller is full on.

42. Motor Heating. — To ascertain whether a motor is suited for a proposed railway service, the conditions of that service must be investigated as already outlined. Barring commutation limitations, the motor must be large enough to dissipate the heat occasioned by the copper and iron losses without excessive temperature elevation. The copper loss over a typical run is equal to the product of the square of the effective motor current and the resistance of the motor windings. The iron loss depends upon the magnetic flux density of the iron and the armature speed. These in turn depend upon the current and upon the voltage impressed upon the motor terminals. If iron loss

curves of the motor, for various current strengths, plotted in terms of motor impressed *E.M.F.* be available, a curve of iron loss for the time during which the power is on the motor can be constructed, since at each instant of time the motor current and voltage are known. Having subsequently determined the average ordinate of such an iron loss curve over the entire run, that voltage may be found which, with the effective motor current, will yield the same total iron loss. Thus, to reproduce the heating conditions of a proposed service in a shop test, it is only necessary to operate the motor for a sufficient time with the effective motor current value which gives the average copper loss at that voltage which gives with this current value the average iron loss. Such continuous operation should not result in a greater temperature rise than 75° C., starting cold. Should the calculations relating to a tentative equipment indicate a greater temperature elevation than this the motors must be discarded and a new set of calculations based upon larger units must be made.

The equivalent voltage on 500 to 600 volt direct-current motors which yields the average iron loss does not vary widely and is generally somewhat less than 250 volts and rarely exceeds 350 volts even on interurban service with infrequent stops. Therefore, the *continuous rating* of a railway motor, which is stated in terms of the current which it can carry with a 65° C. temperature rise by thermometer at $\frac{1}{2}$, $\frac{3}{4}$ and full voltage, gives an accurate idea of its suitability for a proposed service. The *nominal horsepower or kilowatt rating* serves as an indication of the commutating limits and mechanical strength of the motor; it is the mechanical output at the car axle which causes a temperature rise above the surrounding air (taken as 25° C.), by

thermometer, of not more than 90° C. at the commutator and 75° C. on any other accessible part after 1 hour continuous run at rated voltage.

43. Energy for Direct-current Propulsion. — The energy required for the propulsion of cars operating on direct current may be derived from the current and voltage curves of the motor equipment. The watts input to a car at any instant is equal to the line voltage times the instantaneous current per car. Thus a curve of power input can be plotted in terms of time. The area of this power curve would represent the electrical energy consumed during the run.

Having already determined the average current per car in the foregoing numerical illustration over a particular run, namely 51 amperes, it is only necessary to multiply this value by the line voltage and by the total time of the run to obtain the energy consumption. Thus the electrical energy consumed is

$$\begin{aligned} 51 \times 600 \times 144 &= 4,410,000 \text{ watt-seconds,} \\ &= 1,225 \text{ watt-hours,} \\ &= 1.225 \text{ kilowatt-hours.} \end{aligned}$$

In order to effect comparisons between different equipments as to economy of operation the energy consumed must be based upon some definite distance, such as a one-mile run. Energy consumption in kilowatt-hours per car-mile serves as a fair basis of comparison for cars weighing approximately the same but operating at different schedule speeds. When the car weights also differ considerably, the basis of comparison should be the energy in watt-hours per ton-mile.

In the particular case of the 24.32 ton car making the 0.8 mile run under consideration, the energy consumed may be expressed as

$$\frac{1.225}{0.8} = 1.53 \text{ kilowatt-hours per car-mile,}$$

or

$$\frac{1225}{0.8 \times 24.32} = 63 \text{ watt-hours per ton-mile.}$$

44. Energy for Alternating-current Propulsion. — Because of the varying power factor, the calculation of energy consumption of alternating-current railway equipments is not as simple as for the direct-current equipments so far discussed. The process of constructing current curves for the portion of the run after the period of constant acceleration, that is, when full voltage is impressed upon the motors, is exactly the same as for direct-current equipments. The initial portion of the current curve, which refers to the current intake while the car is accelerated uniformly, is, however, difficult of exact determination in the case of alternating-current railway apparatus. The current taken by a single-phase motor increases somewhat during the period of constant acceleration, then decreases again before the expiration of this period, as shown by the curve in Fig. 51. In this figure are shown curves of speed, total motor current, volts on motor, and motor power factor, which were obtained by test with a 50-ton car, equipped with four 75-horsepower, single-phase motors, over a two-mile run.

In the absence of such experimental data, the current taken by the motors of a proposed equipment for the period of uniform acceleration may be assumed constant at the value corresponding to the speed at which the rate of acceleration diminishes. On this assumption the current curve would have the form *OABC*, the portion *BC* being determined from the motor performance curves corresponding

to the various speed values. The average motor current, or the effective current over the run, is then readily obtainable.

Since the voltage impressed upon an alternating-current series motor at the first controller notch is usually about one-half of its final value, no great error will be introduced in the calculation of energy consumption by assuming that the motor voltage increases from the above-mentioned starting value uniformly to its maximum value. Thus, in Fig. 51, the actual voltage curve *HG* may with sufficient exactness be replaced by the curve *EFG*. The average motor voltage may in this way be found without a knowledge of the experimental irregular curve.

By making these two assumptions regarding the form of those portions of the current and voltage curves which correspond to the period of uniform acceleration of the car, the power taken by motors may be computed in kilovolt-amperes. The power factor of alternating-current railway motors on full voltage at different current inputs is embodied in the performance curves thereof. On the lower motor voltages during the period of initial acceleration the power factor is low. Its value during this time may be considered as increasing uniformly to its value at full voltage, with the supposedly constant accelerating current, from a value at starting equal to about 40% of its value at the instant when full voltage is applied to the motors. Thus, the actual power-factor curve of the motors shown as *PMN* in Fig. 51 may be represented by the curve *LMN*. This assumption makes possible the calculation of the power input to the motors in kilowatts. The total energy consumption of the equipment may be obtained by adding to this motor input the losses in the compensators, transformers, and car wiring.

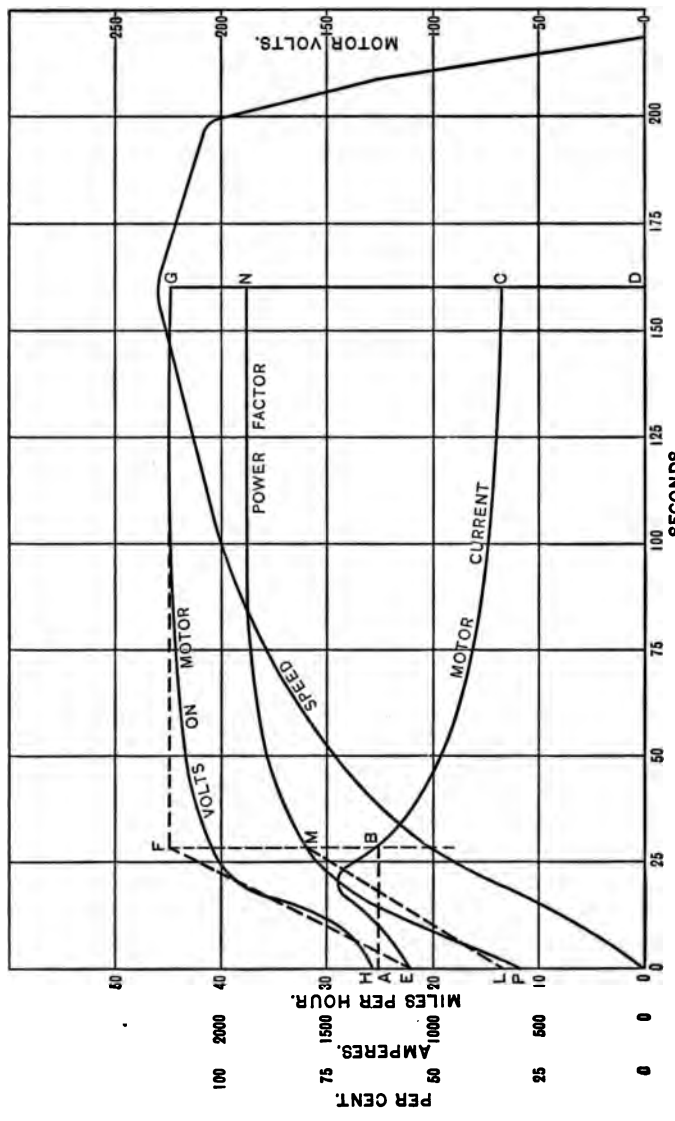

Fig. 51.

45. Effect of Operating Conditions on Energy Consumption. — In order to determine the effect on the energy consumption of a railway equipment when the operating conditions are changed, such as altering the initial rate of acceleration, the length of run, the number and duration of stops, the gear ratio, the braking rate, and the line voltage, it is necessary to consider how the total energy taken from the trolley or third rail is expended. The energy supplied to a car or train during acceleration changes the momentum thereof, and the greater part of this energy appears in the kinetic form, the remainder being expended in overcoming train resistance and in heating the starting rheostats and motor circuits. In bringing the car to rest subsequently the kinetic energy must be dissipated. Left to itself, the car would continue to move until all its energy of motion is lost in overcoming train resistance, and if, as is the usual case, the car is quickly brought to standstill after coasting for a time, the greater portion of the kinetic energy is consumed in heating the brake shoes and car wheels. Thus, the energy supplied to railway equipments is the sum of (*a*) the energy required to overcome the train resistance throughout the entire run, (*b*) the energy wasted in the starting rheostats, motors, and car wiring, and (*c*) the energy consumed in braking.

A slight reduction in train resistance such as might be effected by the employment of ball or roller bearings in diminishing bearing friction, permits of a higher rate of acceleration with the same motor current. The greater the acceleration rate the more coasting is possible on a given run for the same schedule speed and the shorter is the time during which the motors receive power. A considerable saving of energy may result from the reduction

of train resistance to a minimum. With a given equipment the energy expended in overcoming train resistance is approximately constant for a given run.

The energy lost in the starting resistances is proportional to the time that these devices carry current. The losses in the car wiring are usually small enough to be neglected in considerations of this kind. The motor iron losses and the loss in the gears are practically constant over the period during which the power is on. The copper loss in the motors

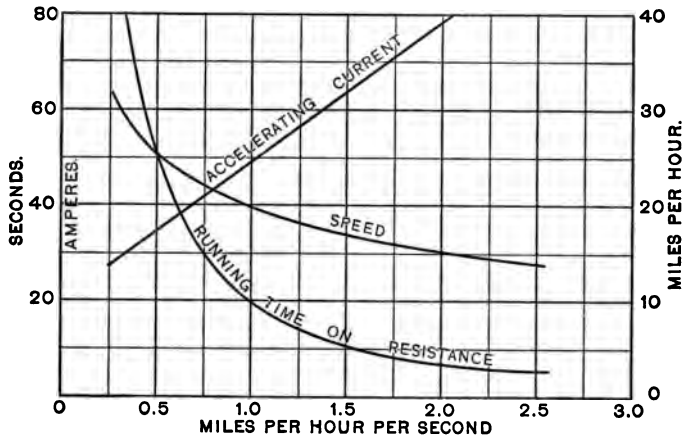

Fig. 5a.

is proportional to the square of the current, and therefore the higher rates of acceleration with the accompanying larger currents result in a greater loss and consequent increase of heating in the motors. On the other hand, increased acceleration implies a shorter time during which the motors receive energy, and therefore tends to reduce heating. These two opposing conditions suggest that there is a definite rate of acceleration which will yield a minimum heating in a given case.

The energy consumed in braking depends upon the braking rate and upon the speed of the car when the brakes are applied. More coasting is permissible on a given run when high braking rates are employed, and the car speed at which braking begins is lower. Braking immediately after turning off the power and thus bringing the car to rest slowly results in inefficient operation.

The curves of Fig. 52 show the motor current during the period of initial acceleration, the time of running on resistance, and the speed of the car at the instant of full-voltage application to the motors, in terms of the acceleration rates, for the 24.32-ton car already mentioned, which is equipped with four 50-horsepower, direct-current motors. These curves are plotted from the following data taken from the characteristic curves of the motors, Fig. 23.

Acceleration rate.	Total tractive effort per motor.	Accelerating current.	Speed at full voltage with initial accel. current.	Running time on resistance.
.25	222	27.0	31.8	127.2
.5	374	34.7	25.5	51.0
.75	526	42.2	22.0	29.4
1.0	678	49.5	19.7	19.7
1.25	830	56.3	18.1	14.5
1.5	982	64.0	16.9	11.3
1.75	1134	70.6	16.0	9.1
2.0	1286	77.7	15.2	7.6
2.25	1438	85.0	14.5	6.5

(Train resistance taken as 70 pounds.)

The curves verify the foregoing general statement that the greater the rate of acceleration the larger will be the current during uniform acceleration of the car but the shorter will be the time during which this current flows; and they show the dependence of these factors upon the rate of acceleration for this particular equipment. The

maximum schedule speed possible on any given run is a direct function of the rates of acceleration and braking.

The maximum possible schedule speed increases with larger runs, provided all other conditions remain unaltered. Thus, in the case of the 24.32-ton car to which frequent reference is made, the relation between maximum schedule speed and the length of the run on level track, allowing for

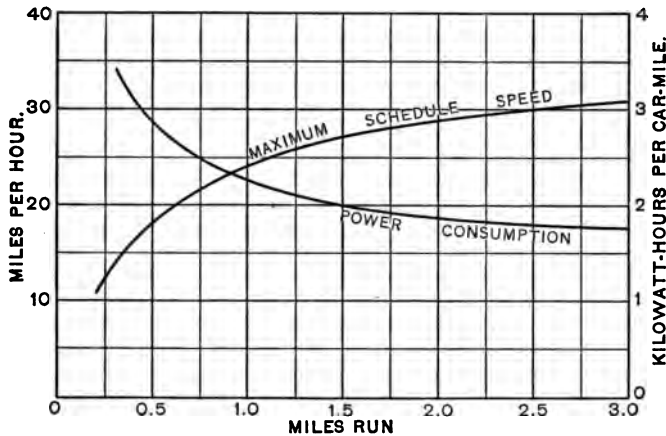

Fig. 53.

20-second stops but no coasting, is shown in Fig. 53. This curve is based on data obtained from Fig. 31, on which a number of braking curves may be drawn corresponding to runs of various lengths.

Proportionately less of the energy taken from the supply circuit is used to overcome the losses in other than train resistance for long runs than in short runs, and therefore the power consumption per mile is decreased by increasing the lengths of runs. This is also shown in Fig. 53 for the particular car under consideration; the curve of power consumption per car mile without coasting was computed in

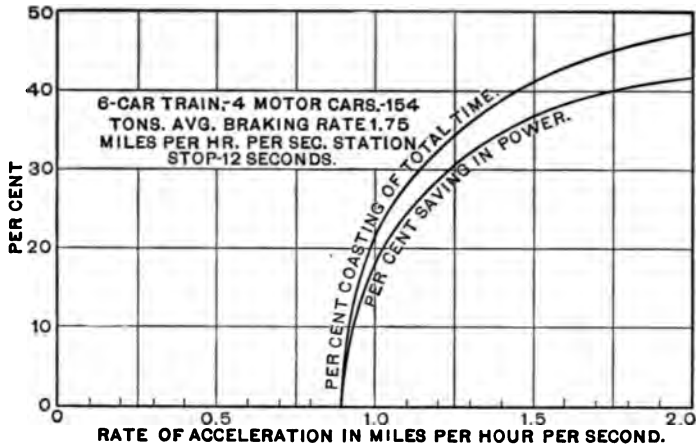

Fig. 54.

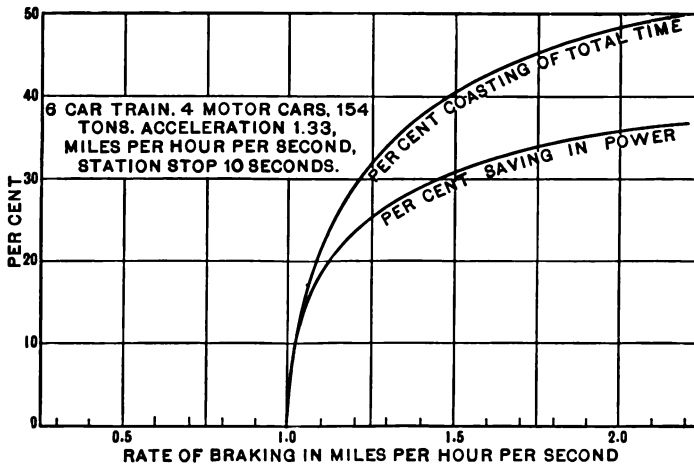

Fig. 55.

connection with Fig. 49. The effect on schedule speed and on energy consumption of changes in the rates of acceleration and braking is not as conspicuous on long runs as on short ones.

The schedule speed of railway cars depends to a great extent upon the duration of the stops for the purpose of taking on or discharging passengers or freight. Obviously, the longer the period of standstill the lower will be the maximum schedule speed attainable by a given equipment.

An increase in the time of coasting results in a reduction of the power consumption. The results of a series of tests on a 6-car train of the elevated railway in New York City

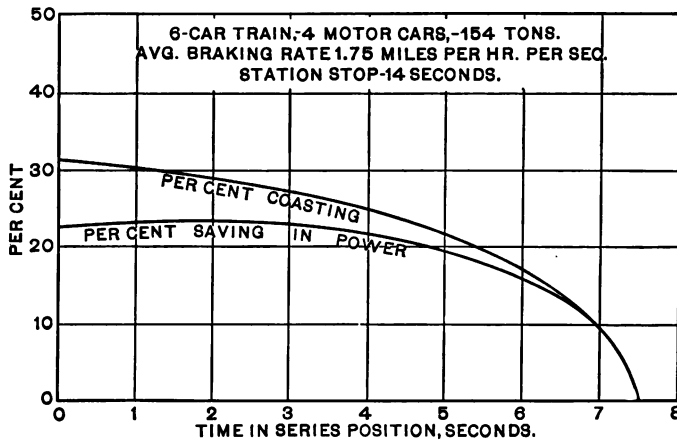

Fig. 56.

made by H. S. Putnam are embodied in the curves of Figs. 54, 55 and 56, which show for a given schedule speed the influence on the percentage of coasting and percentage saving in electrical energy, of acceleration and braking rates, and of running time in series position.

The motor performance curves and the speed and power curves derived from them refer to a definite and constant trolley voltage. In practice this voltage has not the same value at different points on the roadway, owing to the drop

of potential along the trolleys, on third rail, and on feeders from the substations. The minimum voltage at the car should not be less than 350 volts for the usual 600-volt equipment. Consequently in selecting the car equipment for a proposed railway service due attention must be given to the voltage regulation on various parts of the road.

Speed curves of cars operating on road sections on which the voltage is lower than normal must be based upon the average voltage existing at the definite locality. With series motors the speed at constant load varies almost directly with the impressed voltage, and hence the speed of the car at the instant full line voltage is applied to the motors is lower when the line voltage is below normal. Thus to maintain the same services under reduced voltage requires that the motor receive power for a longer time, and this frequently implies a greater power consumption. Sufficient trolley voltage all along the car route is important, particularly so on grades.

46. Gear Ratio. — When a railway motor takes a certain current at constant voltage a definite torque is developed, and the corresponding tractive effort produced by the motor at the base of the car wheels depends entirely upon the gear ratio, that is, the ratio of the number of gear teeth to motor-pinion teeth. The resulting speed of the car for this motor current is inversely proportional to the tractive effort, and consequently the smaller the gear ratio the higher will be the speed of the car and the lower will be the tractive effort available for acceleration. Therefore, to maintain a specified initial rate of acceleration requires a larger current through the motors when geared for high car speed than when provided with a large gear ratio (i.e., low car speed). On the other hand, the time

that power is on the motors of a car when operating over a given run is longer with high gear ratios than with low ratios. The effect of change in gear ratio on the rate of acceleration with a definite accelerating current and on the magnitude of this current with a definite acceleration rate, is indicated respectively in the two following tables which refer to the 24.32-ton car equipped with four 50-horse-power, 600-volt, direct-current motors whose characteristic curves are shown in Fig. 23 for a gear ratio of 17 to 69 (or 4.06).

Gear ratio.	Rate of acceleration.
1.5	0.48
2.0	0.68
3.0	1.08
4.06	1.50
5.0	1.87

(Accelerating current
=64 amperes per motor.)

Gear ratio.	Accelerating current per motor.
1.5	142
2.0	110
3.0	80
4.06	64
5.0	55

(Acceleration rate=1.5 miles
per hour per second.)

By constructing speed and power curves over a typical run for a given equipment when supplied with different gears, and subsequently plotting curves of power consumption and of effective heating current in terms of gear ratio, that gear ratio for the equipment can be determined which is conducive to a minimum expenditure of energy and least heating of the motors. In general, it develops that the most suitable gear ratio for motors of proper capacity for a specified service is that which will yield the lowest car speed consistent with the prescribed schedule speed, due allowance being made for delays. A gear ratio so chosen will result in a low energy consumption by the motors and a small temperature elevation.

PROBLEMS.

24. Upon the speed curve of Problems 17 and 18 plot the curve of current and power input per motor car. In determining the speed of the car at which the transition from the series to the parallel connection of the motors is made neglect the motor voltage drop. Compute the average current and power input per motor car over the time of the complete run.

25. Calculate the energy consumption, in kilowatt-hours per train-mile and in watt-hours per ton-mile, of the train considered in Problems 17, 18, and 24.

26. How much energy in kilowatt-hours is consumed by the equipment of the 20-ton car mentioned in Problems 14 and 15 over the run for which the service conditions are there specified? What is the equivalent heating current on this particular run?

27. Determine from the curves of Fig. 51 the energy consumption in watt-hours per ton-mile of the 50-ton car equipped with four 75-horsepower, single-phase motors. Add 8% of the power taken by the motors to allow for other losses in the car equipment.

28. Plot curves of initial current, full voltage speed with initial accelerating current, and time of running on reduced voltage, all in terms of the rate of acceleration, for a 100-ton New Haven electric locomotive equipped with four 250-horsepower, single-phase motors whose characteristic curves are shown in Fig. 25. Assume train resistance uniform at a value of 15 pounds per ton.

29. Construct a curve showing the maximum schedule speed possible, in terms of the duration of a stop, for the car whose typical speed curve on a level track is shown in Fig. 31.

30. A motor car, weighing 43 tons, equipped with two 200-horsepower motors (gear ratio 20 : 63), whose characteristic curves are shown in Fig. 24, gains velocity at the rate of 2 miles per hour every second on a tangent level track. Assuming train resistance as 15 pounds per ton, plot a curve of the accelerating current required per motor when the equipment is provided with different gear ratios, in terms of gear ratio.

CHAPTER VII.

THE DISTRIBUTING SYSTEM.

47. **Classification of Conductors.** — It is common to divide the conductors of the distributing system into two parts, the ones which convey current from the station to the cars being termed *positive* and those which return it being termed *negative*.

The positive conductors may be divided into three classes as follows: (1) bare *contact conductors*, such as trolley wires, third rails, and T conductors in slot systems, from which the current for propulsion is taken by means of collecting devices; (2) *supplementary conductors*, which are parallel to the contact conductors, are connected with them at frequent or infrequent intervals, and which are designed to increase or supplement their conductivity; and (3) *feeders* which extend from the station to a *feeding point* on the contact or supplementary conductors, and which supply current to them.

The negative conductors may be similarly classified, although the bare conductor which receives current from the car is not usually termed a contact conductor. It usually consists of the connected track rails, although it may be a second trolley wire or T conductor in a slot system. Negative feeders and supplementary conductors are also common.

The contact conductors are usually divided into successive *sections* each one of which is insulated from adjacent sec-

tions. Their lengths vary from a few hundred feet to several miles.

48. Contact Conductors. — To determine the drop assume a contact conductor BD , Fig. 57, fed at B with I

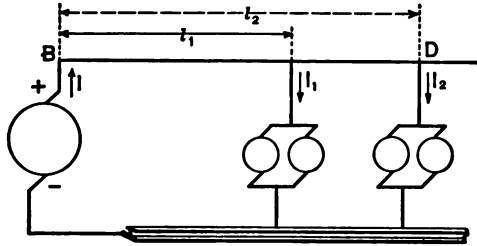

Fig. 57.

amperes, I_1 and I_2 amperes being drained from it at distances from B of l_1 and l_2 feet respectively. If the specific resistance of the conductor be ρ ohms per mil-foot and its cross section be A circular mils, then the drop from B to D is

$$e = \frac{\rho}{A} [l_1(I_1 + I_2) + I_2(l_2 - l_1)],$$

or

$$e = \frac{\rho}{A} (l_1 I_1 + l_2 I_2) \text{ volts.}$$

Similarly in general, if any number, n , of currents of different magnitudes I_m be drained off at different distances, l_m from B , the total drop from B to the most distant point of drainage may be expressed as

$$e = \frac{\rho}{A} \sum_1^n (l_m I_m) = \frac{\rho}{A} l_0 \sum_1^n (I_m) = \frac{\rho}{A} l_0 I \text{ volts,} \quad (1)$$

where $l_0 = \frac{\sum (l_m I_m)}{\sum (I_m)}$ is such a distance from B that if the total current I were carried that far the resultant drop

would be e volts. The relations which exist between the currents, the distances, and l_0 are so similar to those which exist between the elementary and total masses of a body, the respective distances of the former from a plane, and the distance of the center of gravity from the plane, that the point which is l_0 feet from B is termed the *center of gravity* of the combined drainage load.

The total drop in a section of contact conductor is almost always assumed. Taken together with the drop in the negative part of the system it must not be so great as to hinder the proper starting and operation of the motors and the proper functioning of the lamps. The maximum drop in the negative conductors is usually made small with a view to meeting municipal ordinances or to preventing electrolytic corrosion. In England it is limited to seven volts. The total drop varies from 10% to 50% of the normal voltage, the smaller value ruling in all alternating-current and in urban direct-current systems, while the larger is found in direct-current interurban systems. Knowing, therefore, the value of e , if the length of conductor and the distribution of the load be given, the proper cross section may be determined from (1) as

$$A = \frac{\rho}{e} l_0 I \text{ circular mils.} \quad (2)$$

The minimum cross section of the contact conductor is dictated by mechanical considerations in the case of trolley wires, and by manufacturing standards in the case of third rails. The size of trolley wires is usually Nos. 000 or 0000 B. & S., although No. 0 has been used. With double-track roads and those single-track roads which employ twin trolley wires the sum of the cross sections of the two wires should be taken. If, therefore, the cross section, the

drop, and the load distribution be known, the limiting length of contact conductor which can be fed from a single feeding point may be determined by means of formula (1).

The specific resistance of third rails varies with their chemical composition. Armstrong recommends the following limitations as to ingredients:

Carbon not to exceed	0.12 per cent
Manganese not to exceed.....	0.40 " "
Sulphur not to exceed.....	0.05 " "
Phosphorus not to exceed.....	0.10 " "

Such compositions result in a resistivity of approximately 14 microhms per centimeter cube at 20° C., a value which is seven and three-quarters that of commercial copper. The following table of rail resistances is based upon this value:

RESISTANCE OF THIRD RAILS INCLUDING BONDS

Rail weight in pounds per yard.	Resistance in ohms per mile.
40	0.093
50	0.074
60	0.062
70	0.053
80	0.046
90	0.042
100	0.038
110	0.034

Inasmuch as the current taken by a car varies with the time and location of the car and, in congested districts, is subject to further variations due to traffic conditions and the idiosyncrasies of the motorman, it is customary to assume a uniform drainage of I_0 amperes per foot from the contact conductor when treating urban or suburban problems where several cars are taking current at the same time from the same section. The value of I_0 changes

during the day, and for calculating limiting conditions the rush-hour value should be taken. Its average value may be determined by multiplying the average current taken by each car in passing over the section by the number of cars on the section at one time and dividing this product by the length of the section. The ratio of its

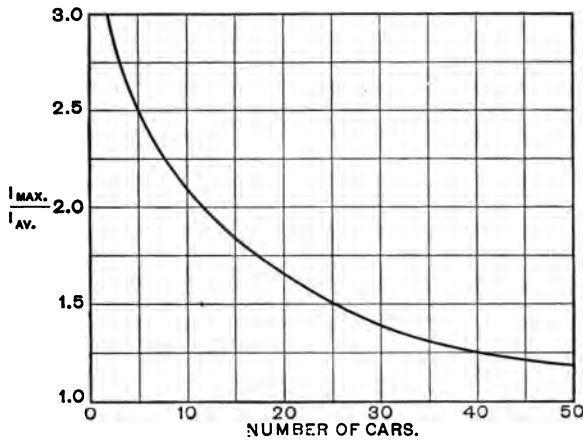

Fig. 58.

maximum to its average value may be determined by reference to Fig. 58, which is based upon experience.

End Feeding. Consider a section of length L feet, fed at one end as in Fig. 57, and let it be uniformly loaded. Since the current density $I_0 = I/L$, and the distance of the center of gravity of the aggregate load $l_0 = L/2$, the total drop over the section is

$$e = \frac{\rho}{A} \frac{L}{2} I = \frac{\rho}{A} \frac{L^2}{2} I_0 \text{ volts,} \quad (3)$$

whence

$$L = \sqrt{\frac{2 A e}{\rho I_0}} \text{ feet.} \quad (4)$$

The total drop is therefore proportional to the square of the length of the section, and the maximum permissible length of section is to be obtained by use of equation (4).

Center Feeding. If the section be fed at its middle point instead of at the end, the permissible length of contact conductor section is twice that indicated by equation (4). Such a system is schematically represented in Fig. 59, and is considered ideal from an operating viewpoint, for each section may be controlled by a circuit breaker at the station in the feeder supplying that section. This gives complete

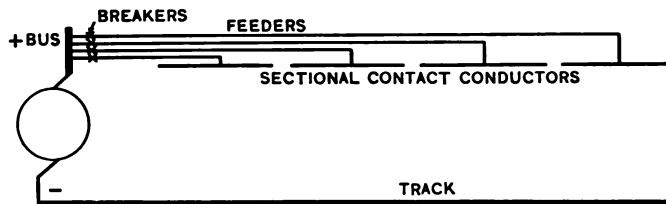

Fig. 59.

control of each and every section in case of overload, short circuit, accident, or repairment. It is the system most frequently used for urban roads. It may be desirable to connect the adjacent ends of the sections of the contact conductor through a section breaker which may be located on a near-by pole. When these circuit breakers are closed there results an equalization of the current distribution and the conductivity of the whole positive system becomes available. The remoteness of these breakers from the station, however, is objectionable as lacking accessibility.

Watts Lost in Conductor. While the cross section of the contact conductor is usually prescribed by the maximum permissible drop or by mechanical considerations, cases may arise where a larger cross section will prove more

economical. In such cases the power lost in the contact conductor may be found as follows:

Let I_e = effective current per foot in amperes,

R = resistance per foot in ohms,

L = total length of conductor from feeding point in feet.

Then the power lost in an elementary length dl of the conductor at a distance l feet from the feeding point is

$$dP = [I_e (L - l)]^2 R dl$$

and the total power lost is

$$P = I_e^2 R \int_0^L (L^2 - 2Ll + l^2) dl,$$

or

$$P = \frac{L^3}{3} I_e^2 R \text{ watts.} \quad (5)$$

For a section fed at one end, L represents the length of the section. If the section be fed at the middle and be $2L$ feet long, the loss will be twice that given by equation (5). The proper cross section is then determined by Kelvin's law as in § 62.

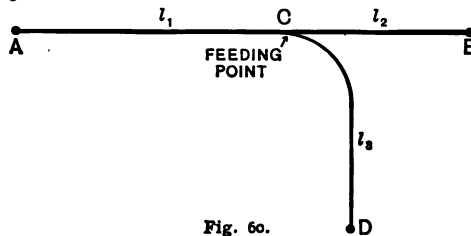

Fig. 60.

49. Branches. — When a contact conductor section is bifurcated because of a branch in the roadway as shown in Fig. 60, and when it is fed at the point of bifurcation, the drainage current on each part may be found as follows:

Let m = number of cars operating between A and B ,
 n = number of cars operating between A and D .

Then at any time:

$$\text{number of cars between } A \text{ and } C = n_1 = m \frac{l_1}{l_1 + l_2} + n \frac{l_1}{l_1 + l_3},$$

$$\text{number of cars between } C \text{ and } B = n_2 = m \frac{l_2}{l_1 + l_2},$$

and

$$\text{number of cars between } C \text{ and } D = n_3 = n \frac{l_3}{l_1 + l_3}.$$

The drainage current per unit length, I_{0n} , for any part of the section may be expressed in terms of the average current per car, I_c , as

$$I_{0n} = \frac{n_n I_c}{l_n} \text{ amperes.}$$

50. Collecting Devices.— The conduction of current to the motors on the cars from the contact conductor is accomplished by means of wheels, rollers, or sliding bows for trolley wires, of shoes for third rails, and of plows for slot systems.

Trolley wheels are grooved wheels of from 3.5 to 6 inches in diameter and are mounted in self-lubricating bearings at the end of a trolley pole. The other end of the pole is movably mounted in a trolley table upon the top of the car and is controlled in a vertical plane by springs and levers so as to exert a fairly uniform pressure between the wheel and the trolley wire, irrespective of the angle of elevation of the pole. This pressure varies from 15 to 40 pounds. The maximum current which can be collected by this means decreases with the speed and is represented in the curve of Fig. 61. If it be necessary to collect more current than that indicated by this curve, either a plurality of

trolley wheels or some other form of collecting device must be used. When the direction of car movement is reversed, it is necessary to turn the trolley pole through 180° in a horizontal plane so that it may incline to the rear of the car. To avoid this shifting, use is sometimes made of cylindrical rollers mounted in pantograph frames on top of



Fig. 61.

the cars. The contact is not as good as in the case of a grooved wheel, and the inertia of the heavy frame tends to produce arcing at the contact with high speeds.

The sliding-bow collector, mounted upon a spring-controlled pole or pantograph frame, is rapidly coming into use, especially in connection with alternating-current systems. This form of collector is more common in Europe than in this country.

The construction and principle of operation of shoes depend upon the character of the third-rail mounting with which they are to be used. With an *overrunning* third rail, as used on the Manhattan Elevated Railroad in New York, and mounted as shown in Fig. 62, the pressure between the shoe and the rail surface is due to the weight

of the shoe. The construction of a shoe adapted to such conditions is shown in the figure. In case the third rail is *protected* against sleet and accidental contact by an insulating barrier at one side and over its top, or is of the *underrunning* type, the shoe is generally hinged and the contact pressure is controlled by springs. The construction of such a shoe for use with the latter type of third rail is shown in Fig. 63. The current-collecting capacity of shoes is very large, 2000 amperes per shoe for speeds up to 35 miles per hour being attainable.

Since the plows used with slot systems must conduct current to and from the car motors, their circuits must be carefully insulated from each other, and, as the slot aperture is of necessity narrow, they usually assume a thin, flat form. Spring-controlled wings at their lower ends serve to form the circuit with the contact conductors on either side in the conduit underneath the slot.

51. Supplementary Conductors.

— When a supplementary conductor is of uniform cross section throughout its length and is connected with the contact conductor at successive

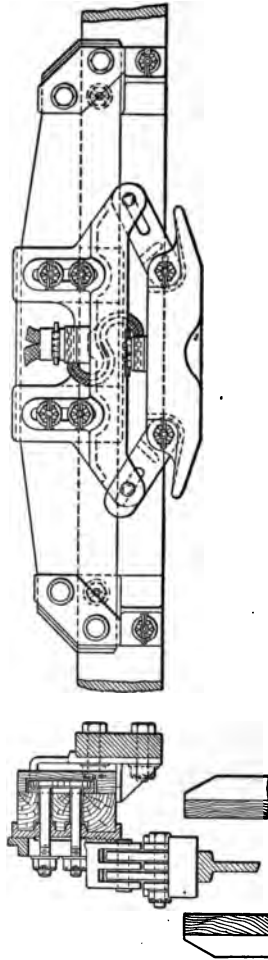

Fig. 62.

points near to each other, the two may be considered as a single composite contact conductor of cross section equal to the sum of the two.

The economic use of copper requires, however, that the cross section of the supplementary conductor be not uni-

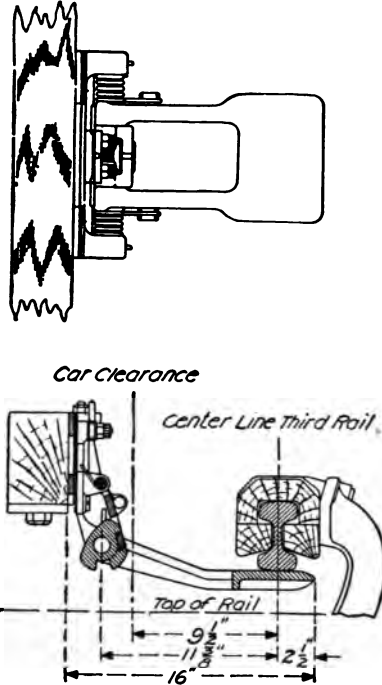

Fig. 63.

form. Consider such a composite contact conductor section to be fed with I amperes at one end and to be divided into m short elements, each of length l feet, and of different cross sections, that of the n th element from the remote end being y_n circular mils. For a uniform drain of current I_0

amperes per foot, the current in the n th element is nI_0 , the volume of the element is $y_n l$ circular mil-feet, its resistance is $\rho l / y_n$ ohms, and the drop over it is $n\rho I_0^2 / y_n$ volts. If v be the total volume of copper and e be the total drop, then

$$v = \sum_1^m l y_n = l \sum_1^m y_n \text{ circular mil-feet} \quad (1)$$

and

$$e = \rho I_0^2 \sum_1^m n / y_n \text{ volts.} \quad (2)$$

Therefore substituting the value of l from (2) in (1),

$$v = \sqrt{\frac{e}{\rho I_0}} \frac{\sum_1^m y_n}{\sqrt{\sum_1^m n / y_n}} \text{ circular mil-feet.} \quad (3)$$

In order that the copper volume v may be a minimum dv/dy must be a minimum, which involves the conditions that $\sum_1^m y_n$ be a minimum while $\sum_1^m n / y_n$, or the total drop, remain constant. If each term of the latter be multiplied by an unknown constant C , to be determined later, the result will still be a constant. Further, if each term of the result be added to the corresponding term of the series $\sum_1^m y_n$, a new series will be formed, of the form $z = \sum_1^m \left(\frac{Cn}{y_n} + y_n \right)$, which also must be a minimum. Therefore

$$\frac{\partial z_n}{\partial y_n} = 1 - \frac{Cn}{y_n^2} = 0.$$

$$\therefore y_n = \sqrt{Cn},$$

and since $nl = x$, the distance in feet of any chosen point from the remote end, substituting the value of n

$$y_x = \sqrt{\frac{Cx}{l}} \text{ circular mils.} \quad (4)$$

To determine the value of C , consider that the drop in an element of length dx at a distance x from the remote end is

$$de = \frac{\rho I_0 x dx}{y_x} = \rho I_0 \sqrt{\frac{l}{C}} \sqrt{x} dx;$$

therefore the total voltage drop is

$$e = \rho I_0 \sqrt{\frac{l}{C}} \int_0^L x^{\frac{1}{2}} dx = \rho I_0 \sqrt{\frac{l}{C}} \frac{2}{3} L^{\frac{3}{2}} \text{ volts.} \quad (5)$$

Since the total entering current, I , is equal to the product of I_0 and the total length of the section, L , the value of

$\sqrt{\frac{C}{l}}$ from equation (5) becomes

$$\sqrt{\frac{C}{l}} = \frac{2}{3} \frac{\rho I \sqrt{L}}{e};$$

consequently

$$y_x = \frac{2}{3} \frac{\rho I \sqrt{L}}{e} \sqrt{x} \text{ circular mils.} \quad (6)$$

This equation shows that the curve which relates total cross section of supplementary and contact conductor with distance from the remote end is a parabola with its vertex at the remote end. Of course it is not practicable to construct a conductor with such a varying cross section, but it is common to reduce the cross section by steps as the remote end is approached.

The connection of the supplementary to the contact conductor at many points involves considerable expense especially when made through contact switches. It is therefore

common practice to employ a moderate number of connections and to feed sections at each end and often from separate substations. In many instances this arrangement is used when the load is concentrated rather than uniformly distributed. In such cases the determination of the proper

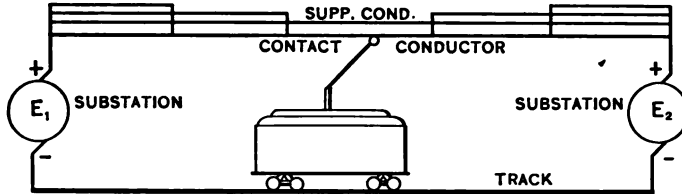

Fig. 64.

disposition of copper is involved and is best arrived at by trials based upon assumed distributions of copper and of load.

Assume a system connected as in Fig. 64 which is electrically equivalent to the arrangement shown in Fig. 65,

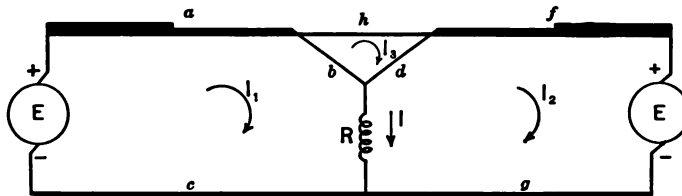

Fig. 65.

where the resistances of the various branches and the voltage at the substations are known and the equivalent resistances R of the load and x of the rest of the conducting system, out and back from both substations and considered as connected in parallel, are to be found. The problem is solved by applying Kirchhoff's laws, which result in the following equations, where the resistances

$$\left. \begin{aligned} A &= a + b + c \\ B &= d + f + g \\ C &= b + d + h \end{aligned} \right\} \text{ohms.} \quad (7)$$

$$\left. \begin{aligned} AI_1 & & -bI_3 + IR &= E \\ & BI_2 & -dI_3 - IR &= -E \\ -bI_1 - dI_2 + CI_3 & & &= 0 \\ I_1 - I_2 & & &= I \end{aligned} \right\} \quad (8)$$

Solving for R by means of determinants

$$R = \frac{\begin{vmatrix} A & 0 & -b & E \\ 0 & B & -d & -E \\ -b & -d & C & 0 \\ 1 & -1 & 0 & I \end{vmatrix}}{\begin{vmatrix} A & 0 & -b & I \\ 0 & B & -d & -I \\ -b & -d & C & 0 \\ 1 & -1 & 0 & 0 \end{vmatrix}} = \frac{\begin{vmatrix} A & -b & (E-AI)/I \\ B & -d & -E/I \\ -(b+d) & C & b \end{vmatrix}}{\begin{vmatrix} A & B & -(b+d) \\ -b & -d & c \\ 1 & -1 & 0 \end{vmatrix}} \text{ohms.} \quad (9)$$

Whence the voltage impressed upon the load is

$$RI = \frac{E(b+d)^2 - E(A+B)C - (Ad^2 + Bb^2 - ABC)I}{(b+d)^2 - (A+B)C} \text{volts.} \quad (10)$$

The drop e between either substation and the load is

$$e = xI = E - RI \text{ volts,} \quad (11)$$

where x is the equivalent resistance in ohms of the conducting system between the substations and the load. The drop between a substation and any point with a plurality of variously located loads is equal to the sum of the drops produced by each load.

52. Graphic Time-table.— Since the reason for the employment of supplementary conductors is the prevention of an excessive drop of voltage between the substations and the cars, the conductors must be of adequate

cross section to cope with the worst condition likely to arise in the operation of the electric railway. As the voltage drop varies with the current and with the resistance, and the latter is proportional to the length of the conductors, the worst condition will be when a maximum total current is taken by cars at a maximum distance from both substations. To determine this condition use is made of *graphic time-tables* or *train-sheets* for the proposed service; such a curve is shown in Fig. 66. It consists of a set of intersecting curves, each one constituting the locus of the correlated time and place relations of a car or train. The ordinates may represent the hours of the day, while the abscissæ represent distances from the road terminus in miles. The curves are usually considered as made up of straight-line elements. With equal scales for ordinates and abscissæ the cotangent of the angle between a portion of the curve and a parallel to the axis of abscissæ represents the corresponding speed in miles per hour. If the elements be straight the speed is constant, and in plotting these curves the average running speed is assumed to be maintained throughout. The perpendicular elements represent stops of durations proportional to the lengths of the elements. The ordinate of a point where two curves cross each other gives the time when the corresponding cars meet each other, while its abscissa determines the necessary location of a turnout, if the road have but a single track. For a specific problem the time-table should have indicated upon it also the distribution of copper and the location of towns, villages, and substations.

Confining the attention to a single section of the road, and assuming an average value of current taken by a car when running and another greater value when starting, the

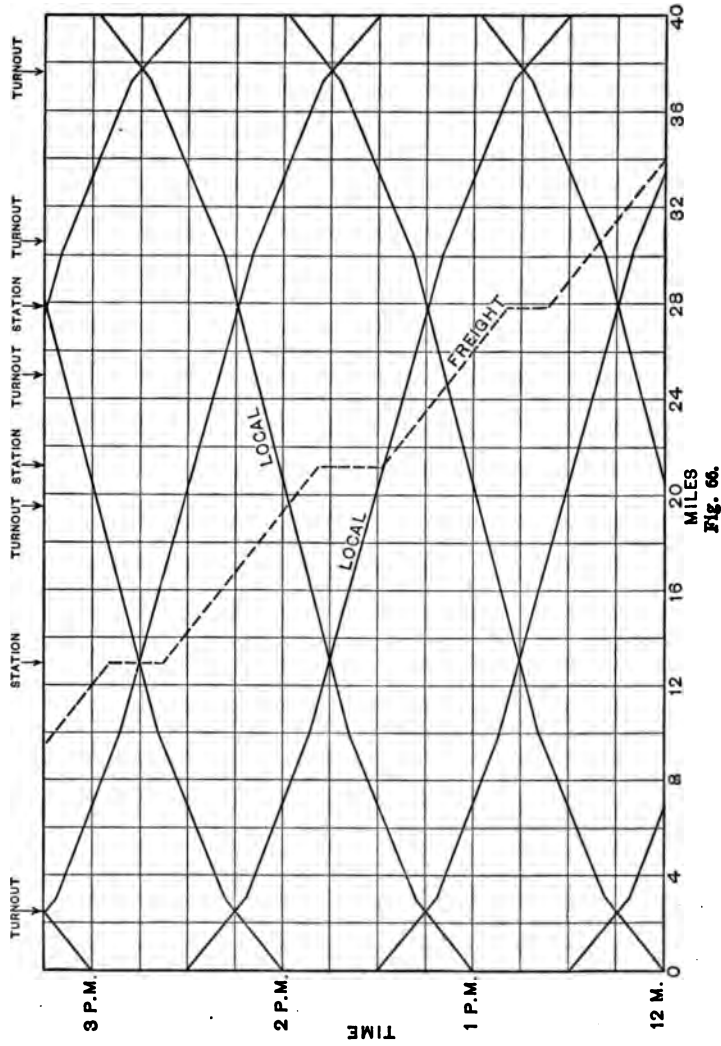

Fig. 66.

magnitudes of the currents and the distances from the substations of their points of drainage, corresponding to any chosen time, can be readily obtained. A comparison of the results for different times readily reveals the worst condition likely to arise. With single-track interurban roads giving infrequent train service such condition is likely to occur when and where two trains pass each other.

Having determined the worst condition, the adequacy of the assumed distribution of copper can be determined by the method outlined in the preceding section. The minimum voltage permissible at the car on 600-volt systems is 300 volts, or with high-class service 350 volts.

In the case of a supplementary conductor with numerous connections with a contact conductor which extends between

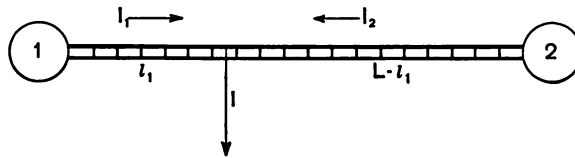

Fig. 67.

two substations and is fed by both, the drop produced by a concentrated load is proportional to the current and to the distance from the nearer substation. Consider the conditions as represented in Fig. 67. If R be the resistance in ohms per foot of combined conductor, the drop is

$$e = RI_1 l_1 = RI_2 (L - l_1) \text{ volts.} \quad (1)$$

$$\text{But} \quad I = I_1 + I_2 \text{ amperes;} \quad (2)$$

$$\text{hence} \quad e = RI \left(1 - \frac{l_1}{L} \right) l_1 \text{ volts.} \quad (3)$$

Therefore, for a given current I , the drop increases with increase of l_1 from $l_1 = 0$ to $l_1 = \frac{L}{2}$. These equations also

show that the portions of the current supplied to a car by the two substations vary inversely as their respective distances from the car.

53. Feeders. — Although supplementary conductors are often termed “auxiliary feeders” or simply “feeders,” the latter term is used in this text to represent conductors which extend from the station to a single feeding point and which carry the same current at the same time through every cross section. The cross section of a feeder is often determined from economical considerations and by the use of Kelvin’s law as modified by Kapp: The most economical area is that for which the annual cost of energy wasted is equal to the annual interest on that portion of the capital outlay which can be considered proportional to the weight of metal used.

Let I = maximum current in amperes carried by the feeder,

L = length of feeder in feet,

A = its cross-section in circular mils,

h = effective annual hours of operation at maximum current,

ρ = resistance of feeder in ohms per mil-foot, and

w = weight of a mil-foot in pounds.

Then the resistance of the feeder is $\frac{\rho L}{A}$ ohms, and, if the

cost per kilowatt-hour delivered to the feeder be c_3 dollars, the annual expense for energy lost in the feeder is

$$C_f' = \frac{c_3 \rho h I^2 L}{1000 A} \text{ dollars.} \quad (1)$$

At a cost of c_2 dollars per pound of feeder conductor and

at a rate for interest and depreciation of p_2 , the annual charge against capital outlay for feeder conductor is

$$C_f'' = p_2 c_2 w L A \text{ dollars.} \quad (2)$$

With overhead construction the cost of insulators and of installing the feeder will be independent of the cross-section for a specific case. Therefore the most economic cross-section is that which will make $C_f' + C_f''$ a minimum, in which case $C_f' = C_f''$ and the economic cross-section is

$$A = I \sqrt{\frac{c_3 h \rho}{1000 p_2 c_2 w}} \text{ circular mils.} \quad (3)$$

Hence the maximum economic drop is

$$e = \frac{I \rho L}{A} = 31.6 L \sqrt{\frac{p_2 c_2 w \rho}{c_3 h}} \text{ volts.} \quad (4)$$

The reciprocal of the radical in equation (3) may be termed the *economic current density*. Often the maintenance of a suitable operating voltage or the inevitable heating of a feeder precludes the use of the economic cross section. Long feeders may be fed from a special bus at the station at a potential somewhat in excess of the normal station voltage.

In case the feeders are to be placed underground, an expression must be obtained for the annual expense chargeable against the cost or rental of conduit ducts in terms of the feeder cross-section. This expression must then be added to equations (1) and (2) before differentiating in order to obtain a minimum.

Boosters.—In the case of feeding points remote from the station the cross section of feeders as prescribed by the permissible drop may be very large and may entail an almost prohibitive first cost. The cross section may be materially reduced if a booster be inserted in the feeder circuit.

Whether or not a booster should be used depends upon its cost and the expense of its operation and maintenance as compared with the saving resulting from the reduced feeder cross section. The determination of the advisability of its use and of its voltage may be made as follows, neglecting the losses in the booster:

Let x = maximum voltage of booster,
 e_f = maximum total drop in boosted feeder,
 I = maximum amperes in feeder,
 p_1 = interest, depreciation, etc., on cost of booster,
 f and g = cost constants.

Then

$$\text{Capacity of booster} = \frac{Ix}{1000} \text{ K.W.}$$

$$\text{Cost of booster} = f + g \frac{Ix}{1000} \text{ dollars.}$$

Hence the annual interest and depreciation on the booster is

$$C_1 = p_1 \left(f + g \frac{Ix}{1000} \right) \text{ dollars.}$$

If h be the yearly effective hours of feeder operation and c_3 be the cost in dollars of generating a K.W.-hour, the annual cost of energy lost in the feeder is

$$C_2 = \frac{I(x + e_f)}{1000} hc_3 \text{ dollars.} \quad (5)$$

If the length of the feeder be L feet, and its weight be w pounds per mil-foot, its cross section is

$$A = \frac{\rho IL}{x + e_f} \text{ circular mils,} \quad (6)$$

and its weight is

$$W = \frac{w \rho IL^2}{x + e_f} \text{ pounds.} \quad (7)$$

At a cost of c_2 dollars per pound and a rate of interest, etc., of p_2 per cent, the annual feeder expense is

$$C_3 = \frac{c_2 p_2 w \rho I L^2}{x + e_f} \text{ dollars.} \quad (8)$$

The total annual feeder and booster expense therefore is

$$C = C_1 + C_2 + C_3,$$

or

$$C = p_1 \left(f + g \frac{Ix}{1000} \right) + \frac{I(x + e_f) h c_3}{1000} + \frac{c_2 p_2 w \rho I L^2}{x + e_f} \text{ dollars.} \quad (9)$$

In order that this expression may be a minimum its differential coefficient with respect to x must equal zero, or

$$\frac{dC}{dx} = p_1 \frac{gI}{1000} + \frac{I h c_3}{1000} - \frac{c_2 p_2 w \rho I L^2}{(x + e_f)^2} = 0;$$

therefore

$$(x + e_f)^2 = \frac{c_2 p_2 w \rho L^2 1000}{(p_1 g + c_3 h)}$$

and

$$x = L \sqrt{\frac{1000 c_2 p_2 w \rho}{p_1 g + c_3 h}} - e_f \text{ volts.} \quad (10)$$

Since x must be a positive quantity, that value of L which makes it equal to zero is the minimum length of feeder with which the use of a booster is advisable. It should be noted that this minimum length increases as the yearly hours of boosted-feeder operation increase. Boosters are therefore to be especially recommended for intermittently operated feeders. If the average efficiency of the booster set be ϵ , multiplication of the term $c_3 h$ in (10) by $(2 - \epsilon)$ will include the losses of the set.

With the following values for the constants — those in brackets being suggestive of the order of magnitude — equation (10) may be simplified for use with copper feeders:

$$\begin{array}{ll}
 \rho = 10.5. & c_3 = [0.006]. \\
 w = 0.00000303. & p_1 = [0.10]. \\
 c_2 = [0.17]. & f = [300]. \\
 p_2 = [0.06]. & g = [28].
 \end{array}$$

$$x = 0.018 L \sqrt{\frac{1}{2.8 + 0.006 h}} - e_f. \quad (11)$$

For a total boosted-feeder drop of 50 volts and continuous operation of $h = 24 \times 365 = 8760$ hours, the minimum length of feeder to be boosted is found by making $x = 0$. It is

$$L = 20,650 \text{ feet.}$$

An infrequent operation would indicate a poorer load factor and accordingly higher cost per kilowatt-hour c_3 . Assuming $h = 1000$ hours and $c_3 = 0.01$ the minimum length becomes

$$L = 10,000 \text{ feet.}$$

54. Track Rails. — The size of track rails is determined by consideration of the mechanical requirements of the rolling stock, the schedule speed, and the character of ballast. The common sizes weigh from 60 to 100 pounds per yard of length. The specific resistance varies with the chemical constitution and, as carbon and manganese are usually present to the extent of about one-half per cent, amounts to about 20 microhms per cubic centimeter, while that for standard copper at 0° C. is 1.594. It is convenient to assume that for average temperatures it is ten times that of commercial copper.

The usual length of a rail is 30 feet, although twice this length is sometimes used. In order satisfactorily to return the current to the station from the car, the rail sections must be conductively connected with each other by means

of *bonds*. These bonds are often made of copper, which has a much larger temperature coefficient of expansion than steel. As a consequence, it is not easy to maintain a good electrical contact between a copper bond terminal and the rail, under varying temperatures and the displacements caused by traffic. Many forms of these bonds have therefore been devised. The most satisfactory forms have their terminals either brazed to the rail or mechanically expanded in a hole in the web or flange of the rail. When heavy current-carrying capacity is desirable and the density of traffic warrants the expense the rail sections may be welded to each other.

It is desirable to use a pair of bonds for each joint, when they are of copper, to insure continuity of the circuit in case one bond should fail. With such bonding the resistance per mile of 30-foot rails may be assumed as 10% larger than if the rail were continuous.

For convenience in calculating the voltage drop in tracks the following values for the resistance of two track rails in parallel including that of 9-inch bonds of half the carrying capacity of the rail are given:

RESISTANCE OF TRACK RAILS INCLUDING BONDS.

Weight of rail, pounds per yard.	Resistance per mile, ohms.
40	0.066
50	0.053
60	0.044
70	0.038
80	0.033
90	0.030
100	0.027
110	0.024

55. Negative Track Feeders.— In those systems which make use of the earthed track rails for returning current from the car motors to the generating station, differences of potential exist between different points along the rails; as a consequence, the neighboring soil takes a part in the conduction of the return current owing to the presence in it of moisture, of dissolved substances, and of pipes or other metallic subsurface structures. At the points where the current leaves the rail to enter the connection from the negative bus at the station, electrolytic corrosion occurs to an extent dependent upon the ampere-hours conducted. It is therefore desirable that this leakage current from the rails should be made as small as possible. Its magnitude is dependent upon that of the potential differences along the rails, and varies inversely as the resistance offered by the earth. It is not often that the engineer can alter the earth resistance, but he can materially vary the potential distributions along the rails by using negative supplementary conductors or feeders, connected to the track at predetermined points, which serve as auxiliary return conductors. Owing to the large cross section offered to the current by the earth, its chief resistance, outside of that existing at the ground plate for the negative bus at the station, is that due to the layers of soil in the immediate vicinity of the rails, and this may be, and hereinafter is, considered as a transition resistance of a ohms per foot length of track (two or four rails) and varying inversely as the length. In the case of a track whose rails are connected to the ground and to the negative bus at the power house, if the excesses of potential, e , of the various points in the track above that of the negative bus be represented by the ordinates of the curve of Fig. 68, while the abscissæ repre-

sent distances in feet from the power house, then the leakage current dI , escaping at the point l to the soil from an elementary length, dl , of track, is represented by the proportionality

$$dI \propto \frac{edl}{a}, \quad (1)$$

and the total leakage current is proportional to the area

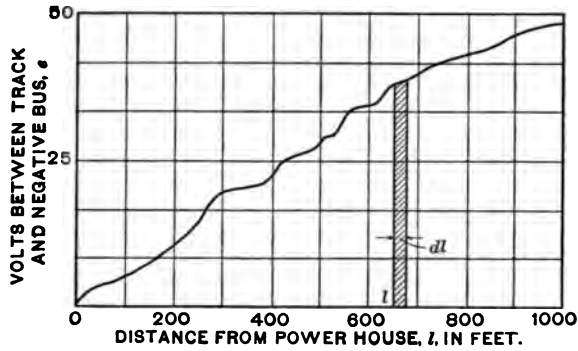

Fig. 68.

included between the potential curve and the axis of abscissæ, or

$$I \propto \frac{1}{a} \int_0^L edl. \quad (2)$$

In order to compare the relative merits for the reduction of leakage current of various proposed dispositions of the same amount of return copper, it is desirable that analytical expressions be obtained for e in terms of the distances, l , from the power house for each proposed disposition. Substitution can then be made in (2) and that disposition which yields the minimum value of the integral may be adopted.

As an illustration, consider a single generator supplying

I amperes to trolley feeders for a single-track road extending L feet in only one direction from a station, the load being uniformly distributed along the line. Assume that the negative terminal of the generator is grounded at the station and that one negative supplementary conductor of uniform cross section, and bonded to the rails at short intervals, extends from the station to the end of the line.

Let l = distance in feet of any point on the line from the station,

i = current at this point in amperes,

e = voltage of track at this point above negative terminal of generator,

r = resistance in ohms per foot of return, including rails and negative supplementary conductor,

ρ = ohms per mil-foot of copper,

A_i = copper cross section in circular mils equivalent in conductivity to the track rails,

A_c = cross section of negative supplementary conductor in circular mils.

Then

$$i = I \left(1 - \frac{l}{L} \right) \text{ amperes,} \quad (3)$$

$$r = \frac{\rho}{A_i + A_c} \text{ ohms,} \quad (4)$$

$$e = \int_0^l i r dl = \frac{\rho I}{A_i + A_c} \left(l - \frac{l^2}{2L} \right) \text{ volts.} \quad (5)$$

The curve coördinating voltage to distance is therefore a parabola, and the area contained between it and the l axis, that is, the value of the integral in equation (2), is

$$\int_0^L e dl = \frac{\rho I}{A_i + A_c} \frac{L^2}{3}. \quad (6)$$

George I. Rhodes has compared various dispositions of return copper and concludes that a maximum reduction of leakage current can be obtained by the use of several insulated negative feeders of such cross section that the average potentials at their feeding points are maintained

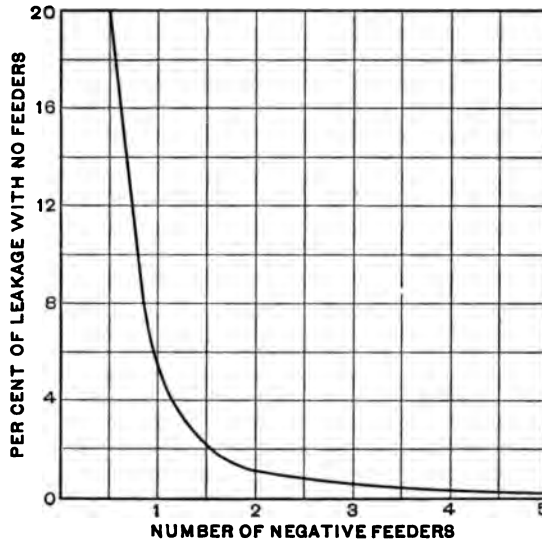

Fig. 69.

equal, the negative bus bar being insulated from the ground at the station.

If, in addition, use be made of negative boosters in the feeders, the potentials at the feeding points can be maintained uniform with that of the negative bus-bar even with widely fluctuating loads.

The amount to which the original leakage current is reduced by various numbers of such negative feeders and boosters as a percentage of what would exist in the case of no feeders, is shown in Fig. 69.

If the contact-conductor sections be supplied by individual feeders and the current of each be passed through the field exciting coil of the booster which is connected to the track feeder for the corresponding section, as indicated in Fig. 70, the potential of the track feeding points can be kept practically equal to that of the negative bus at the station. It should be noted that the track rails are insulated from the negative bus. This arrangement of connec-

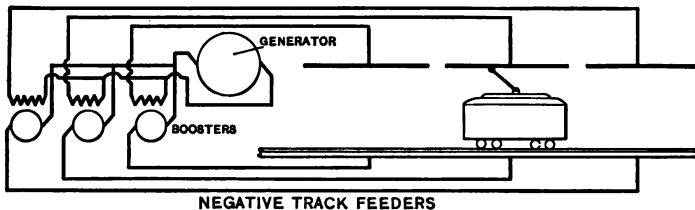

Fig. 70.

tions is the most effective one for minimizing electrolytic corrosion in those systems which return current through the grounded track rails.

56. Electrolytic Surveys.—The determination as to whether and to what extent track feeders shall be installed depends upon the conditions which result from the operation of a road. These conditions are usually found by making an *electrolytic survey* and studying the results thereby attained. The difference of potential between the tracks and the various pipe systems is measured at many points throughout the roadway. Care must be taken that good terminal contacts be secured, for these differences seldom amount to more than a few volts. Upon a map, which clearly shows all the tracks, the potential differences are plotted as ordinates with respect to the track as abscissæ, and a curve is drawn through their ends. Wherever the

track is positive with respect to the pipe the area included between the curve and the track is generally colored blue. In case it be negative the area is colored red, indicating that the potential conditions at such places are favorable to corrosion of the pipes.

Another map is prepared from which the tracks are omitted but upon which the pipe system under investigation is indicated. The magnitude and direction of the currents flowing in the pipes at various points, especially in the red districts, are obtained and are indicated on this map by arrows of proportionate length and direction. Currents may be measured by the drop-of-potential method, using a low-reading millivoltmeter. The portion of the pipe over which the drop is to be obtained must be insulated from the earth and therefore excavations are generally necessary. A study of this map is likely to reveal the location of points where electrolytic corrosion is likely to take place. Thus, if at two points on an unbranched pipe currents be simultaneously flowing towards each other, the conclusion is inevitable that they both leave the pipe at an intermediate point. Again, if a large current flow towards a point where a smaller one is flowing in the same direction, the excess of the former must leave the pipe at intermediate points.

A relatively high potential difference between a track and pipe does not necessarily indicate that a large current is flowing between them, for such would not be the case if the resistance offered by the soil were large. It may be desirable to know whether the current be large or not, and this can be determined by the use of Haber's earth ampere-meter. It consists of a wooden frame in which is mounted a plate of glass with a copper plate on each side of it. The free surfaces of the latter are covered with a thin layer of

• paste, made of copper sulphate and 20% sulphuric acid, and held in place by parchment. This frame is buried in the soil transverse to the supposed path of current flow. Leads from the copper plates are connected with a milli-ammeter which will indicate the flow of current through the soil. The device is non-polarizable, and experience shows that its presence in the soil does not distort the current flow-lines.

In order to make the current measurements it is necessary to know the resistance per unit length of the pipe. This may be obtained from the following table published by Prof. A. F. Ganz, based upon a specific resistance of 0.00144 ohm per pound-foot of cast iron and 0.000181 ohm per pound-foot of wrought-iron pipe.

WEIGHT AND RESISTANCES OF CAST- AND WROUGHT-IRON PIPE.

Inside diameter of pipe, inches.	Standard cast iron.		Standard wrought iron.		Extra heavy wrought iron.	
	Weight per foot without hub pounds.	Resistance per foot, ohms.	Weight per foot without hub pounds.	Resistance per foot, ohms.	Weight per foot without hub pounds.	Resistance per foot, ohms.
½			.84	.000215	1.1	.000164
1			1.7	.000106	2.2	.000082
1½			2.7	.000067	3.6	.0000502
2			3.6	.0000502	5.	.0000362
3	11.	.000131	7.5	.0000241	10.	.0000181
4	18.	.000080	10.6	.0000171	15.	.0000121
6	31.	.0000465	18.8	.00000963	29.	.00000623
8	42.	.0000343	28.	.00000647	43.	.00000421
10	55.	.0000262	40.	.00000452	54.	.00000335
12	70.	.0000206	49.	.00000369	65.	.00000278
16	109.	.0000132				
18	130.	.0000111				
20	151.	.00000955				
24	205.	.00000702				
30	294.	.00000490				
36	408.	.00000353				
48	604.	.00000238				

57. Alternating-current Distribution.—The voltage drops which occur with alternating-current systems are dependent not only upon the resistances of the conductors but also upon their reactances and the phases of the components of current. An adequate general treatment of the subject is out of place in this text. The methods of determining line reactances will be given in a later chapter. The flexibility and cheapness of transformers permit of their extensive use for the equalization of potentials, whereas excessive copper or boosters are essential in direct-current systems.

The high permeability and the hysteresis characteristics of steel track and third rails involve large drops when they carry alternating currents. Skin resistance becomes an important factor and it has been estimated that at frequencies of 15 and 25 the current confines itself to a peripheral depth of but 4 and 3 millimeters respectively. Disregarding any drop due to flux set up outside the rail, its impedance, according to Armstrong, is 8 times the ohmic resistance at 25 cycles and 6.2 times at 15 cycles.

PROBLEMS

31. Calculate the resistance at 20° Centigrade of a 30-foot length of track rail weighing 700 pounds. Take 7.7 as the specific gravity of steel rail.
32. How far from the terminus of a road is the last feeding point to a No. 0000 copper contact conductor supplying 0.01 ampere per foot, if the potential at the feeding point is maintained at 550 volts and the drop in the contact conductor must not exceed 20 per cent?
33. The two cross-bonded contact conductors of the Manhattan Elevated Railroad consist of third rails weighing 100 lbs. per yard. They are fed at both ends from substations which maintain a constant potential of 625 volts. If the distance between substations be one mile and the current drainage from both tracks at maximum load be 0.3 ampere per foot, what is the maximum percentage drop in the contact conductors?
34. Determine the economic cross-section of a copper feeder to carry

350 amperes for 2500 effective hours per year. Assume the cost of a kilowatt-hour as one cent, the cost of a pound of copper 18 cents, and the rate of interest and depreciation as 6 per cent.

35. If the feeder of problem 34 be supplied with current at 550 volts, what is the greatest length which may be used without producing a drop exceeding ten per cent?

36. Plot a curve, based upon the constants given in § 53, which shows the dependence of equivalent hours of operation upon the minimum feeder length for economic installation of a booster assuming an average booster efficiency of 85 per cent.

CHAPTER VIII.

SUBSTATIONS.

58. Types of Substations. — A substation is a station which contains devices which serve to alter the voltage or character of the current received from the transmission line and thereafter deliver it to the distributing system. Substations are of three types, depending upon the character of the received and delivered currents as to whether they are direct or alternating.

59. Direct Currents Received and Delivered. — With the Thury system, which is employed to some extent in Europe but which is not looked upon with favor by American engineers, direct current is generated at the power house, transmitted and received at the substation and direct current is sent out from the substation. A typical example of this system is the plant which transmits power from Moutiers in Savoy to Lyons for the operation of the street railways in the latter city. Sixteen water-turbine-driven direct-current generators, consisting of four sets of four each, are connected in series with each other and can, at full load, generate 3500 volts each or 56,000 volts in all. They supply a constant current of 75 amperes to the line, and their voltage is varied with the load by means of electrically operated regulators connected in series with the line. The sets may be operated singly or together according to the load requirements, a single movement of a controller handle on a simple switchboard serving to cut in

or out a set. The transmission line is 110 miles long, consists of two copper wires 0.354 inch in diameter, and entails a constant loss of 535 kilowatts. It has been found necessary to keep the line connected to the earth through high resistances and to provide numerous lightning arresters.

At the substation the received current is used to operate motors each of 540 horsepower capacity. The speed of the motors is maintained constant by centrifugal regulators which shift the brushes when the load changes. These regulators are criticized as being an inherent defect of the system, for they are complicated and frequently require adjustment and repairs. Each motor is used to drive a 600-volt direct-current generator which is connected with the distributing system. Special precautions are taken to insulate the motors from each other, from the earth, and from the generators which they drive. Tests have shown that the power output of the substation is 0.705 that of the intake of the turbines which drive the generators at the power house. As a precaution against breakdown of the line or power station, the substation is amplified by an auxiliary transformer station in which direct-current motors are direct connected to 10,000-volt three-phase generators, the latter being adapted for connection with the lines of another operating company. These sets are reversible and by means of them energy may be supplied to or received from the other system. The power stations and the substations in this direct-current system cost more than those which use alternating currents for transmission. The cost of the transmission line is less and the maximum voltage, as limited by the appearance of corona, § 72, is greater. The system is lacking in that flexibility which characterizes the use of transformers.

60. Alternating Currents Received and Delivered. — In those systems which employ induction motors on the cars or locomotives, three-phase currents are generated at the power station, and, if the length of the transmission line requires more than an impressed voltage of 12,000 — the upper voltage limit of generators — at least three single-phase step-up transformers or one three-phase transformer must be used. At the substation three step-down transformers must be located, and usually a fourth one is installed as a spare unit. Such substations are designed to

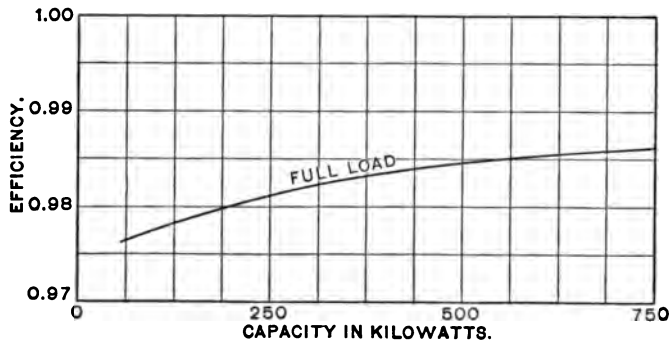

Fig. 71.

operate without an attendant and therefore the transformers are self-cooling and both the primary and secondary circuits are supplied with automatic oil switches adjusted to open on short circuits but not on overloads. Fig. 71 shows the full-load efficiencies of a line of 25-cycle, 11,000-volt air-blast transformers of capacities from 100 K.W. to 750 K.W. The buildings are of fireproof construction, and permanently installed ammeters and voltmeters facilitate the location of possible faults on the system.

In those systems which employ single-phase commutator

motors, if the transmission line be single phase and be long, and consequently the voltage be high, but one step-up and one step-down transformer are necessary. Since, however, it is cheaper to use a three-phase transmission line it is advisable to use a three-phase generator and three step-up transformers at the power station and two step-down transformers at the substation, the latter being connected according to Scott's method for transformation from three-phase to two-phase with connections as shown in Fig. 12. Furthermore, the cost per kilowatt of three-phase generators is but about three-quarters that of single-phase generators, because in the former a single magnetic circuit is used in common by all phases.

Experience has shown that it is practicable to use alternating-current pressures as high as 20,000 volts on overhead contact conductors. In such cases stationary substations may be dispensed with, and voltage reduction, suitable to the requirements of the motors, can be attained by the use of transformers located on the cars or locomotives. In some respects this arrangement is ideal, each motor having a substation and carrying it with it. There are no substations on the electrically equipped portion of the N. Y. N. H. & H. R.R., 11,000 volts being generated and impressed directly upon the contact conductors of the system. Each motor, however, is provided with a transforming device. The locomotives used in the Berlin-Zossen tests were equipped with polyphase motors wound for an impressed pressure of 10,000 volts taken direct from the contact conductors without the intervention of voltage transforming devices.

61. Alternating Currents Received and Direct Currents Delivered. — Substations which convert alternating

current into direct current are the type most frequently used. By means of transformers the voltage of the currents received from the transmission line is stepped down and the secondary currents are supplied to converters or motor-generators which deliver direct currents to the distributing system. The motor element of the motor generators may be either a synchronous motor or an induction motor. The proper selection of the conversion apparatus involves a number of considerations.

Floor Space. — In all cases it is customary to install three single-phase transformers or one three-phase transformer for each converter. Since both induction and synchronous motors are wound for an impressed *E.M.F.* up to 12,000 volts, step-down transformers can usually be dispensed with. Even then the floor space occupied by converters and transformers is less than that required for equivalent motor-generators. Wilson and Lydall give the following values for units of about 750 K.W. capacity:

Converters and transformers, 0.21 sq. ft. per K.W.

Induction motor-generators, 0.31 sq. ft. per K.W.

The possible separate location of converters and transformers, for instance the placing of transformers on a gallery, gives a flexibility of arrangement of apparatus not possessed by motor-generators. With urban substations and expensive real estate the occupied floor space becomes an important factor.

Efficiency. — The efficiency of synchronous converters is greater than that of motor-generators. Even if to the losses of the converters be added the losses in transformers and regulating devices, which are not involved in the use of motor-generators, the efficiency of the combined converter

installation excels. W. R. C. Corson gives the average operating efficiencies from this point of view as follows:

Synchronous converters.....	91%
Synchronous motor-generators.....	85%
Induction motor-generators.....	84%

Figs. 72 and 73 contain curves showing the operating characteristics of a shunt-wound, 25-cycle, 600-K.W. conver-

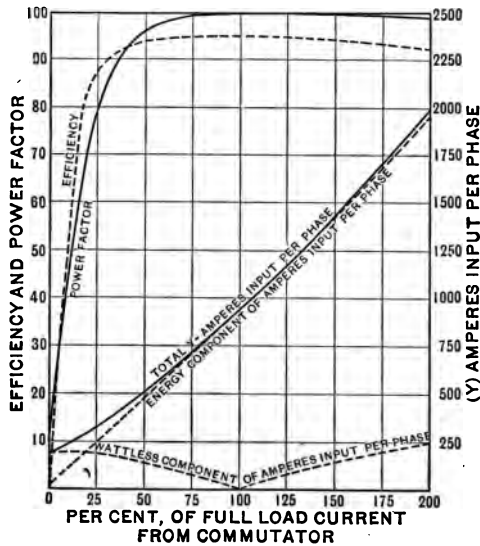

Fig. 72.

ter, and of a 50-cycle, 230-K.W. induction motor-generator respectively.

Regulation. — Since the ratio between the commutator and slip-ring voltages of a converter is practically constant, irrespective of the field excitation, except in the case of split-pole converters, it is customary to insert a reactance coil in the circuit between the low-tension terminal of a

transformer and the converter slip ring which it supplies with current, and to provide the converter with a series magnetizing coil which is traversed by the direct current from the commutator before it enters the feeders of the distribution circuit. The field excitation is thereby caused to increase with load, and the alternating current which enters the slip rings is therefore made to lead the impressed voltage. The passage of the leading current through the reactance coil establishes such phase relation that the vector

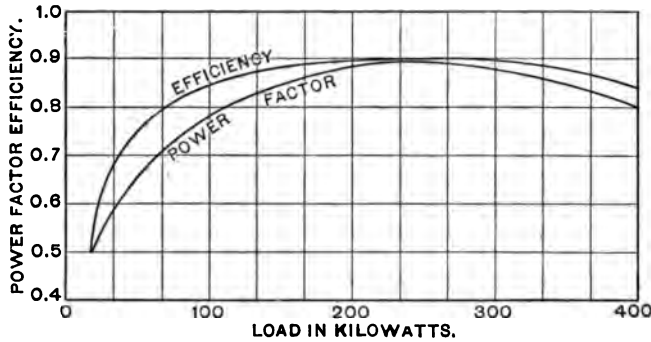

Fig. 73.

sum of the transformer and reactance voltages is greater than the former and therefore the slip-ring voltage is raised with load. The converter with such an arrangement is said to be *compounded*, and may maintain a constant direct-current voltage under wide variations of load. It is usual to provide for each phase a reactance coil of a combined kilovolt-ampere capacity equal to 15% of the rated kilowatt capacity of the corresponding converter. Fig. 74 shows a General Electric Company air-blast reactance set and starting switches for a 1000-K.W., six-phase converter. The operating characteristics of the 600-K.W.

converter previously mentioned, with added series ampere-turns at full load amounting to 64 % of the shunt ampere-turns, are shown in Fig. 75. With proper adjustments of the series and shunt field coils it is possible to make the converter take a lagging current on light loads and a leading current on heavy loads. It therefore increases the power



Fig. 74.

factor of the transmission circuit on heavy loads. This method of regulation, however, fails to give satisfactory results when the line resistance drop exceeds 10 % of the impressed line voltage or even less; and yet on large transmission systems and with long transmission lines it is desirable and often economical to have a drop greater than this. With motor-generators, however, the direct-current voltage can be as easily and satisfactorily regulated as with

plain generators, and the regulation is in nowise dependent upon the drop in the transmission line. Furthermore, by the use of series coils on a synchronous motor field the motor-generator set may be adapted for power factor correction to the same extent as with converters.

Cost. — The cost of converters *per se* is less than that of motor-generators of the same capacity. Compound con-

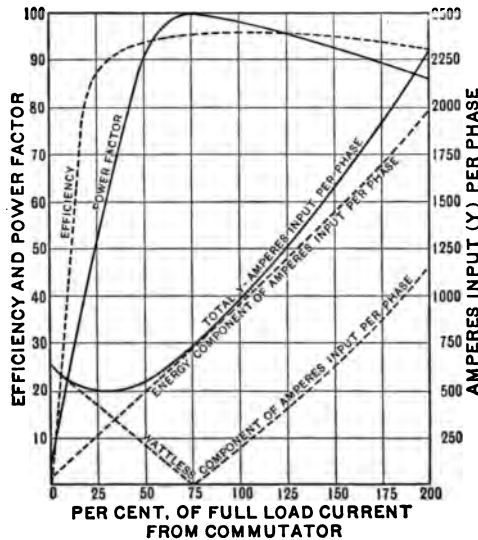

Fig. 75.

verters cost more than shunt converters because of the lower flux density in the iron.

To make a proper comparison of the costs of the two types of installation one should consider the whole system and compare the total cost of converters, regulating devices, transformers, switch gear, ventilation apparatus, and transmission cables with that of equivalent motor-generators, switch gear, and cables. Parshall and Hobart make such a

comparison for a plant supplying three substations each having a rated output of 1800 K.W., the most remote being 6 miles from the power house. The results are given in the following table.

RELATIVE COSTS OF CONVERSION INSTALLATIONS

	Converters.	Motor generators.
High-tension cables.....	\$80,000	\$55,000
Converters (6-900 K.W.).....	67,500	118,000
Motor generators.....		118,000
Transformers and ventilating sets (21-300 K.W.).....	31,500	
Substation switchboards and gear.....	27,000	18,000
Total.....	\$206,000	\$191,000

The smaller cable expenditure with motor-generators results from their ability to operate satisfactorily with a greater line drop than is allowable with converters. Whether the interest on the 7% less outlay with motor-generators would offset the increased operating cost resulting from the smaller efficiency of the motor-generators would require a careful study of the substation load diagrams. The preceding table is based upon the following costs per rated kilowatt:

Converters.....	\$12.50
Transformers and ventilation apparatus.....	5.00
Converter switch apparatus.....	5.00
Motor-generators.....	21.90
Motor-generator switch apparatus.....	3.33

The data concerning the converter equipment relate to an existing substation.

62. Location of Substations. — There are certain points on the roadway of a traction system which may be considered as natural points for the location of a substation.

These are the centroids of load in urban networks, the power house when it is located on the line, and the middle or a point near the remote ends of the terminal sections of the lines. It is also often desirable to have the substation located at a passenger station, thus making it possible for the ticket agent to serve as a substation attendant.

If it be assumed that there is a uniform drainage of current throughout the length of the road and that the contact conductor has numerous connections with the supplementary conductor, the composite conductor, of uniform cross section, extending from one substation to each adjacent substation, then the economic distance between substations can be determined by mathematical treatment.

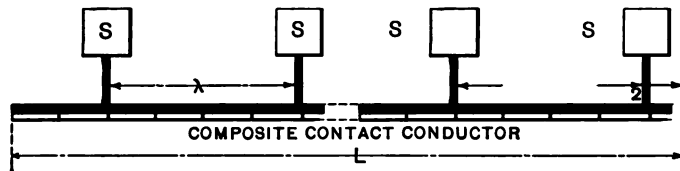

Fig. 76.

Furthermore, if the profile of the road be such that along certain portions the drainage of current is greater than along the rest of the line, each portion by itself can be treated mathematically.

Assume a road of length L feet to be supplied with current from n substations, equally spaced from each other by a distance $\lambda = L/n$ feet, and arranged as in Fig. 76, where the substations are represented by S .

The annual mean effective current per foot of contact conductor can be determined from a study of the train diagrams and from the instantaneous currents per car. The maximum drop, which will occur at a point midway

between substations and at the terminals of the line, is limited to such a value as will permit satisfactory operation of the motors and lighting of the lamps, is known, and *must be used as a check* on the economic drop about to be determined. See problem No. 37.

For a fixed distance between substations, the economic cross section, A , for the composite contact conductor is such that the annual charge for interest and depreciation on its cost is equal to the annual charge for the energy lost in it. To prove this, consider that the former charge is dependent on the weight of the conductor, that is its cross section, and may be placed equal to K_1A , and the latter on the resistance, which may be placed equal to K_2/A , where K_1 and K_2 are constants. The sum of these two charges, x , must be a minimum, hence the differential of x , with respect to A , must equal zero. Therefore

$$\frac{dx}{dA} = K_1 - \frac{K_2}{A^2} = 0$$

and

$$K_1A = K_2/A \text{ dollars.} \quad (1)$$

If now, with a conductor of constant cross section, the distance between the substations be increased, which is equivalent to reducing the number of substations for a road of given length, the resistance and weight of the conductor between stations will be increased proportionately. The interest charge will likewise increase, while the energy charge will increase to a greater extent, because the current entering the section of conductor from the substation has also been increased. Therefore K_2/A is, in this case, larger than K_1A , and to maintain the equality of equation (1) the value of A must be increased.

The increase of distance between substations, or reduction in their number, furthermore affects the charges for interest, maintenance, and operation of all the substations. The wages for fewer attendants and the costs and losses per kilowatt of the larger units installed are thereby decreased. The economic cross section of contact conductor and economic distance between substations, therefore, involves a minimum annual charge for wages, for interest on total cost of copper and equipment, and for cost of total energy lost in copper and equipment. Expressions for each of these items of annual charge must be found in terms of the distance, λ , between substations, and the differential coefficient of their sum, with respect to λ , must be equated to zero in order to determine the economic separation of substations.

It will be assumed that the annual charges against the transmission line, the energy lost in the track, and the cost of substation buildings are not affected by changes in λ . The last two charges can be introduced without difficulty, if desired. The first charge materially alters with λ only in the case of very short lines and very heavy traffic.

Wages. — For a given type of substation, length of line and density of traffic, the necessary number of attendants in each substation and their average wages will not vary with the size of the units, so far as these sizes are dependent upon λ . For all substations, however, they will vary directly with the number of substations, $n = L/\lambda$, and if there be n' attendants per substation, receiving on an average w' dollars per year, the total annual charge for attendants

$$C_w = nn'w' = [n'w'L] \frac{1}{\lambda}. \quad (2)$$

With transformer substations there are no attendants and therefore C_w becomes, in this case, zero.

Charges against Contact Conductor. — Consider that part of the contact conductor of cross section A circular mils which is fed from one substation. Under the assumption of a uniform drainage of I_0 mean effective amperes per foot, the watts lost in each half of the conductor, or $\lambda/2$ feet, are, according to equation (5), § 48, $\rho I_0^2 \lambda^3 / 24 A$. There being 8760 hours in a year, at a cost of c_3 dollars per kilowatt-hour delivered from the substation, the annual charge for the energy lost in λ feet of the conductor is

$$C_c' = \frac{8760}{1000} \frac{\rho c_3}{12 A} I_0^2 \lambda^3 \text{ dollars.} \quad (3)$$

If the cost of conductor be c_2 dollars per pound and w be the weight of a mil-foot in pounds, at an interest rate of p_2 the annual capital charge against the contact conductor is

$$C_c'' = p_2 c_2 w A \lambda \text{ dollars.} \quad (4)$$

Since C_c' must equal C_c'' when the cross section A is most economical, equations (3) and (4) may be equated and solved for A as follows:

$$A = 0.855 I_0 \lambda \sqrt{\frac{\rho c_3}{p_2 c_2 w}} \text{ circular mils.} \quad (5)$$

Substituting the value of A in (4), multiplying by 2 so as to include C_c' and by $L/\lambda = n$ to cover the whole length of line, the total annual charge against contact conductor is

$$C_c = \frac{L}{\lambda} (C_c' + C_c'') = \frac{2L}{\lambda} C_c'',$$

or
$$C_c = [1.71 L I_0 \sqrt{\rho w p_2 c_2 c_3}] \lambda \text{ dollars.} \quad (6)$$

Annual Charge against Substations. — If the total maximum output of all substations be P kilowatts and if the

overload coefficient or ratio of maximum output to rated installed capacity be δ , then the rated capacity of the apparatus installed in each substation is $P/\delta n$ K.W. The overload coefficient is determined from a study of the nature of the load diagram for each substation and from the overload guarantees as to the apparatus. In determining the number of units to be installed in each substation the following points must be considered:

(a) It is desirable and good practice to have the same sized units throughout the system whenever possible.

(b) There are limits as to the maximum size of units to be found among manufacturers' standard lines.

(c) The daily load curve is often of such a character that one unit and several units can be operated for protracted intervals at nearly maximum efficiency.

(d) The maintenance of the continuity of service requires that either a spare unit be installed in each substation or that there should be a portable substation which can be placed on a siding as needs may require.

(e) The peak of the load may be taken by a storage battery installed in each substation.

(f) Provision must be made for increased output with growth of traffic.

Fig. 77 shows the load curve on No. 2 substation of the Manhattan Division of the Interborough Rapid Transit Company on a particular day. This substation was then equipped with six 1500-K.W. converters each having efficiencies of 93.5, 95.75, and 96.0 per cent at half, full, and five-quarters load respectively. They were supplied with alternating current from eighteen 550-K.W. transformers, three for each converter, each having efficiencies of 97, 97.75, and 97.7 per cent respectively at the corresponding loads.

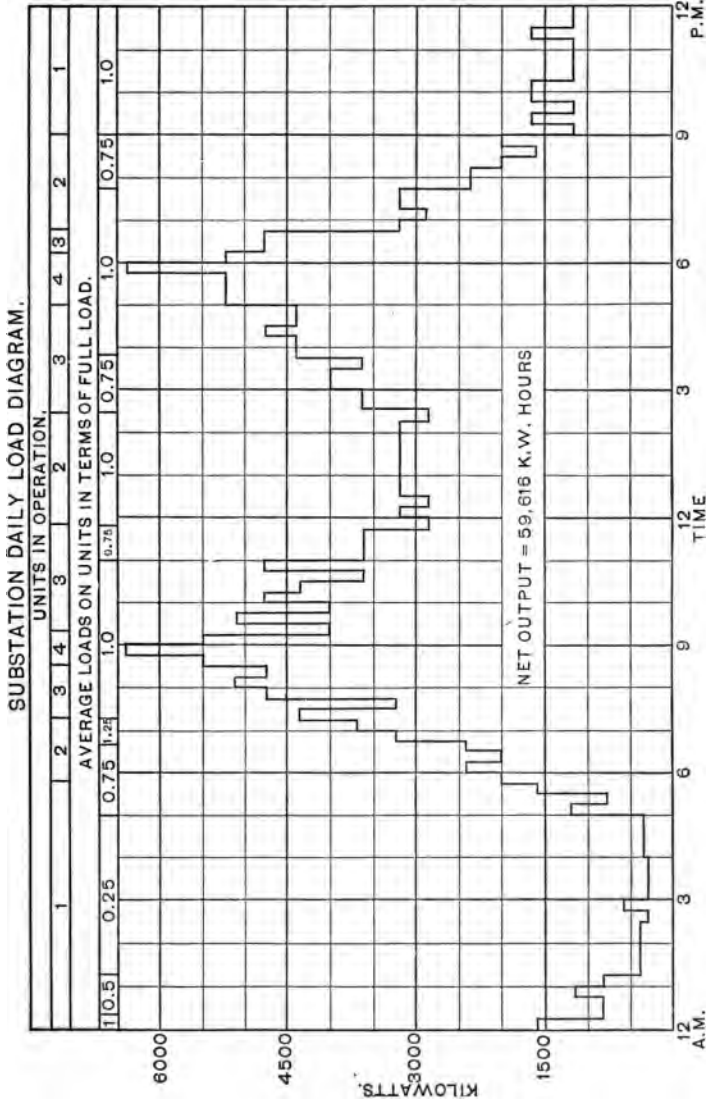

Fig. 77.

Assuming that the overload capacities are as recommended in the Standardization Rules of the A. I. E. E., that is, that they can each carry an overload of 25 % for two hours and 50 % for one-half hour, the load diagram shows the probable operating conditions of these units on this day to be as in the accompanying table, the numbers in the third column indicating the *equivalent number of hours* that a unit must be operated at full load in order that its losses may be the same hypothetically as they are in fact. To determine the equivalent hours, if the efficiency at any load be ϵ , let the expression $(1 - \epsilon)$ be termed the *deficiency* at that load; then the equivalent hours are equal to the product of the number of hours at any load by the ratio of that load times its deficiency to full load times its deficiency.

CONDITIONS OF OPERATION OF UNITS

Unit.	Hours per day.	Equivalent hours per day.
No. 1	24	21.4
No. 2	15.5	15.0
No. 3	8.8	7.5
No. 4	2.0	2.0
No. 5	0	0
No. 6	0	0

Total daily equivalent unit, hours, 45.9

The equivalent annual hours of operation of all units in this substation at full load are therefore

$$h = 365 \frac{45.9}{6} = 2792 \text{ hours.}$$

The load on this substation was about 20 % greater in winter than as shown in Fig. 77, due partly to the current required for car heaters. Instantaneous fluctuations of

current above and below those shown in the figure amounted in some cases to 40 %. In calculating losses in a proposed substation a mean effective load diagram should be used.

To obtain an expression for the annual charge for energy lost in the substation in terms of λ , it is necessary to plot deficiency curves in terms of the rated capacity of units. There should be say three curves, for half, full, and three-halves load respectively. The points on these curves can

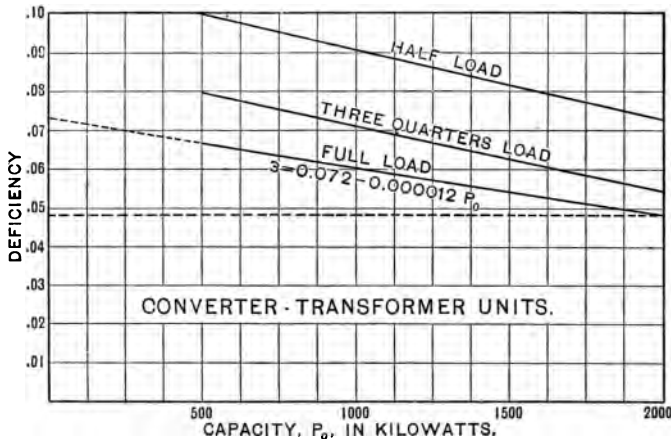

Fig. 78.

be obtained readily from manufacturers' efficiency curves of units for say three rated capacities, as 500, 1000, and 1500 kilowatts. Three such curves for combined transformer-reactance-converter units, at unity power factor, are shown in Fig. 78. The full-load curve is practically straight over the portion covered by the capacities entering into the problem, and the deficiency, λ , may be expressed analytically as

$$\lambda = f_3 - g_3 P_0, \tag{7}$$

where P_0 is the rated capacity in kilowatts.

The following values are suggestive of the order of magnitude of the constants f_3 and g_3 for conversion at 25 cycles from 11,000 volts to 600 volts:

DEFICIENCY CONSTANTS

Units.	K.W.	f_3 .	g_3 .
Transformer-reactance-converter	500 to 2000	0.072	0.000012
Transformer-reactance-converter	200 to 500	0.087	0.000060
Transformers.....	100 to 750	0.024	0.000014

The converters of larger capacity listed in the table are wound six-phase, while those of smaller capacity are three-phase. If there be u units of capacity P_0 kilowatts installed in each substation, including spare units, and h be the equivalent annual hours of operation of all units at full load, then, since $P_0 = P/\delta nu$, the annual loss of energy in all substations is

$$P_0 nu \delta h = \frac{P f_3 h}{\delta} - \frac{P^2 g_3 h}{\delta^2 nu} \text{ kilowatt-hours.} \quad (8)$$

Since $n = L/\lambda$, if the cost per kilowatt-hour of energy delivered to the substation be c_3' dollars, the annual charge against the substations for energy lost in them is

$$C_s' = \left[\frac{P c_3' f_3 h}{\delta} \right] - \left[\frac{P^2 c_3' g_3 h}{L \delta^2 u} \right] \lambda \text{ dollars.} \quad (9)$$

The cost of one unit of capacity P_0 kilowatts can be expressed analytically as $f_3' + g_3' P_0$ dollars, where f_3' and g_3' are constants determined by the manufacturer. The cost of all units to be installed in all substations is therefore $nu(f_3' + P g_3'/\delta nu)$, and, if p_3 be the annual rate covering interest, depreciation, and obsolescence, the annual charge against cost of substation equipments is

$$C_s'' = p_3 n u f_3' + P p_3 g_3' / \delta,$$

or, since $n = L/\lambda$,

$$C_s'' = \left[\frac{P p_3 g_3'}{\delta} \right] + [L p_3 f_3' u] \frac{1}{\lambda} \text{ dollars.} \quad (10)$$

The following values are suggestive of the order of magnitude of the constants f_3' and g_3' .

COST CONSTANTS

Units.	K.W.	f_3' .	g_3' .
Transformer-reactance-converter...	500 to 2000	3200	9.4
Transformer-reactance-converter...	200 to 500	2000	11.0
Transformers	250 to 750	240	2.66

The total annual charge against the substation equipments is equal to the sum of C_s' and C_s'' as given in equations (9) and (10), or is

$$C_s = \left[\frac{P c_3' f_3' h + P p_3 g_3'}{\delta} \right] - \left[\frac{P^2 c_3' g_3' h}{L \delta^2 u} \right] \lambda + [L p_3 f_3' u] \frac{1}{\lambda} \text{ dollars.} \quad (11)$$

The Economic Spacing of Substations. — The economic value of λ is such that the total annual charges or the sum of C_w , C_c , and C_s , as given in equations (2), (6), and (11), shall be a minimum. To avoid needless repetition of the letters entering into the bracketed coefficients of these equations, these coefficients may be represented as follows:

$$\begin{aligned} C_w &= K_w / \lambda, \\ C_c &= K_c \lambda, \\ C_s &= K_s + K_s' / \lambda + K_s'' \lambda, \end{aligned}$$

and their sum as

$$C = K_s + (K_w + K_s') / \lambda + (K_c + K_s'') \lambda.$$

To determine the minimum value of λ , the differential

coefficient of C , with respect to λ , must be placed equal to zero, or

$$\frac{dC}{d\lambda} = -\frac{K_w + K'_s}{\lambda^2} + K_c + K_s'' = 0.$$

Solving,

$$\lambda = \sqrt{\frac{K_w + K'_s}{K_c + K_s''}} \text{ feet,} \quad (12)$$

and substituting the values of the coefficients,

$$\lambda = \sqrt{\frac{n'w'L + p_3 f_3' uL}{1.71 LI_0 \sqrt{\rho w p_2 c_2 c_3} - \frac{P^2}{\delta^2} \left(\frac{c_3' g_3 h}{Lu} \right)}} \text{ feet.} \quad (13)$$

The economic cross section, A , for the composite contact conductor can now be obtained by inserting the value of λ in equation (5).

63. Numerical Illustration. — For the purpose of more clearly understanding the influence of the factors entering into the economic spacing of substations, assume a road 200,000 feet long with converter substations that are to be cared for by two attendants, each receiving \$720 per annum, and each on duty 12 hours each day, every station to be equipped with two converter units of equal size. The cost and deficiency constants will be those applying to units under 500 K.W. capacity. Let the following be the values of the characteristic constants:

$$\begin{array}{ll} P/\delta = 2500 \text{ K.W.}, & \delta = 1.25, \\ I_0 = 0.00875 \text{ ampere per foot}, & p_2 = 0.06, \\ h = 5000 \text{ hours}, & p_3 = 0.10, \\ \rho = 10 \text{ ohms}, & c_2 = 0.18 \text{ dollar}, \\ w = 0.00000303 \text{ pound}, & c_3 = c_3' = 0.01. \end{array}$$

Then

$$\begin{aligned} \lambda &= \sqrt{[2 \times 720 \times 200,000 + 0.10 \times 2000 \times 2 \times 200,000]} \\ &\quad \div \left[\frac{1.71 \times 0.00875 \times 200,000 \times \sqrt{10 \times 0.00000303 \times 0.06 \times 0.18 \times 0.01 - (2500)^2 \times \frac{0.01 \times 0.00006 \times 5000}{200,000 \times 2}}}{[288,000,000 + 80,000,000]} \right]^{\frac{1}{2}} \\ &= \frac{[288,000,000 + 80,000,000]}{\div [2990 \sqrt{0.00000000327 - 0.0469}]}^{\frac{1}{2}} \\ &= \sqrt{\frac{368,000,000}{0.169 - 0.0469}} = 54,800 \text{ feet} = 10.4 \text{ miles.} \end{aligned}$$

Thus, the economic separation of converter substations on this 37.8-mile electric railway is 10.4 miles; consequently

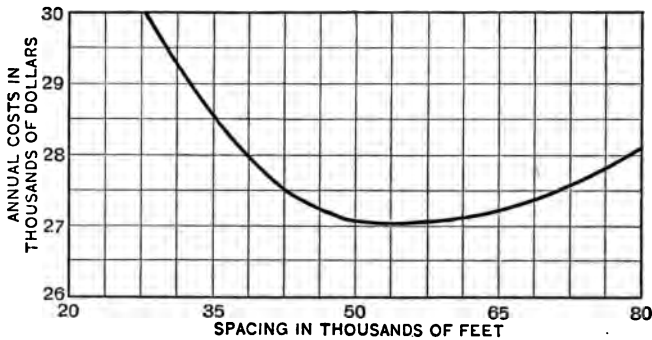

Fig. 79.

4 substations will be required, each equipped with two conversion apparatus units of 300 K.W. rated capacity. That 10.4 miles is the economic distance between substations is proved by computing the various cost items for the railway which depend upon this distance for different values of λ , as in the following table, and as shown in Fig. 79.

Cost items.	Substation spacings in feet.				
	30,000	50,000	54,800	60,000	80,000
Wages, C_w	\$ 9,600	\$ 5,760	\$ 5,260	\$ 4,800	\$ 3,600
Copper, C_c	5,075	8,460	9,280	10,130	13,570
Equipment, C_e	14,885	12,890	12,515	12,145	10,875
Total	\$29,560	\$27,110	\$27,055	\$27,075	\$28,045

Automatic substations, which dispense with operators and avoid their wages, are now in successful operation. At a predetermined low line voltage a contact-making voltmeter actuates a drum controller which, by the use of contactors, places a converter in service. When its output falls to a fixed value a current relay shuts it down. Protective devices do the same in case of short circuits, defect in any device, or failure of supply voltage.

64. Auxiliary Storage Batteries. — If a storage battery in series with a compound-wound booster¹ be connected between the positive outgoing and negative incoming feeders of a substation, the two may be so adjusted as to impress a constant voltage upon these feeders. As a result, a slight decrease of converter voltage under abnormal load allows the battery to discharge into the distributing system, and also a slight increase of converter voltage under subnormal load will cause the battery to receive a charging current from the converter. The use of a battery, therefore, relieves the substation units, the transmission line, and the power station apparatus of violent instantaneous fluctuations of load. If the battery be of sufficient capacity,

¹ For a discussion on the connections and operation of boosters and storage batteries see Chapter VIII, *Dynamo Electric Machinery*, Vol. I, by Sheldon and Hausmann.

it may also serve to carry the peak loads, of not too long duration, which are common on interurban systems. If, again, the battery be of very large capacity, it may serve to carry the characteristic peak loads of an urban system and may serve to supply power to the whole system in case of accident in the power station or on the transmission line. The use of a battery, therefore, may enable one to install smaller units in substations and in generating stations and to operate them under better load factors and therefore at greater efficiencies. It also enables one to design the transmission line for average instead of maximum load conditions. The saving in investment for station equipments and line must however be balanced against the cost of batteries and boosters, and the decreased energy losses must be balanced against the energy losses attendant upon the use of the battery. Furthermore, the cost of extra attendance entailed by the use of batteries must be considered. The proper capacity of such a battery is so closely dependent upon the characteristics of the substation load diagram that the advisability of its installation can be determined only from the study of the specific case.

65. Arrangement of Apparatus. — The arrangement of apparatus in a substation is governed to some extent by the character of the equipment and the size and shape of the available site. It is desirable to have all apparatus on one floor; but, if the equipment be large, the switch gear should be placed on a gallery so that the attendant may command a view of the whole station. In urban districts, where real estate is expensive, the transformers, high-tension switches, and lightning arresters are often placed on a second floor. Storage batteries when used in substations are usually located on another floor or

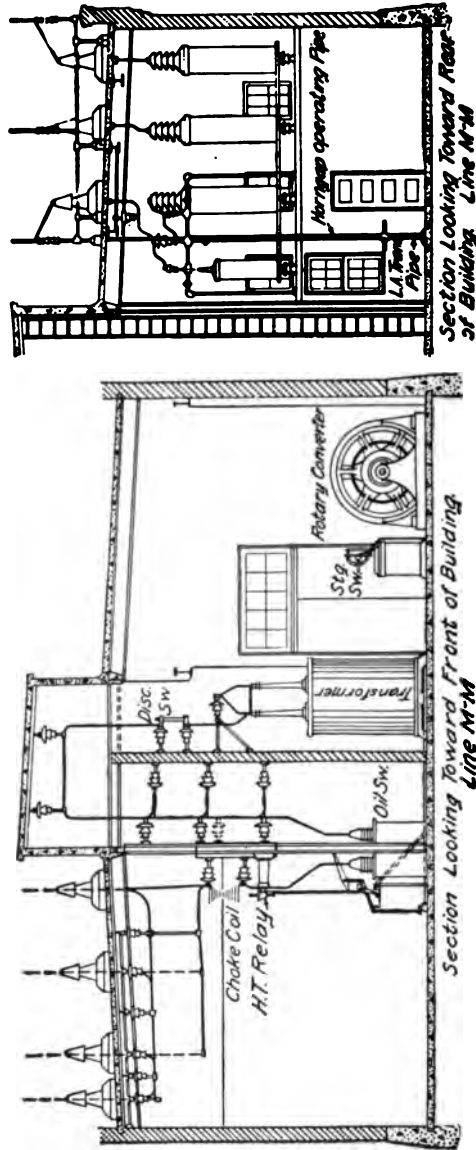

Fig. 80.

in a separate building adjacent to the main substation. The path of energy from the transmission line to the distributing feeders should be as short and direct as possible. This leads to the following arrangement across the station



Fig. 81.

from the transmission line: high-tension entrance devices, lightning arresters and switch gear, transformers, reactances, converters, low-tension switch gear, and outgoing feeders. Fig. 80 is a sectional view of a substation of the Milwaukee Electric Railway and Light Company. This substation has a rated capacity of 1200 K.W. for conversion from 66,000 volts alternating current to 1200 volts direct current.



Fig. 82.



Fig. 83.

Fig. 81 gives a view of the low-tension end of one of the substations of this road, the reactances surmounted by starting panels being shown as located in front of their respective converters. Fig. 82 shows the method of tapping



Fig. 84.

the transmission line on the substation roof, and shows the high-tension roof bushings for insulating the supply wires at their points of entrance to the substation. Figs. 83 and 84 respectively show the electrolytic lightning arresters and the high-tension oil switches and the methods employed in their installation.

66. Portable Substations.— On most electric roads there are certain sections of the line on which abnormally

heavy traffic must be handled at infrequent intervals or only during a certain portion of the year, as for instance near fairgrounds, parks, or summer resorts. To meet such a condition and to guard against interruption of service due to accident to a unit in any substation, it is much cheaper to make use of portable substations than to install permanent spare units. These substations consist of specially arranged cars containing complete substation equipments, of the converter or motor-generator type, with accessories. The standards as to track gauge, height of tunnels, and strengths of bridges limit their characteristics to 500 K.W., 60,000 volts, and 150,000 pounds weight. The external appearance of such a portable substation is shown in Fig. 85. The arrangement of apparatus is shown in the plan and elevation of Fig. 86, and Fig. 87 is a diagram of the circuit connections. The positive feeder cable is carried to a terminal block on the outside of the car near the roof, for convenient connection to the trolley wire or feeder. The incoming high-tension lines may be connected directly to the transmission line; but, if frequent or continued use of the portable substation in one locality is necessary, disconnecting switches should be mounted on the nearest pole to facilitate disconnecting the oil switch without having to cut off power from the transmission line.

The use of such portable stations insures continuity of supply with minimum investment in permanent substations, saves large investment in copper and equipment on lines infrequently loaded, provides additional capacity at any point where there may be a temporary abnormally heavy traffic, and may furnish power for extensions during the period of construction.



Fig. 86.

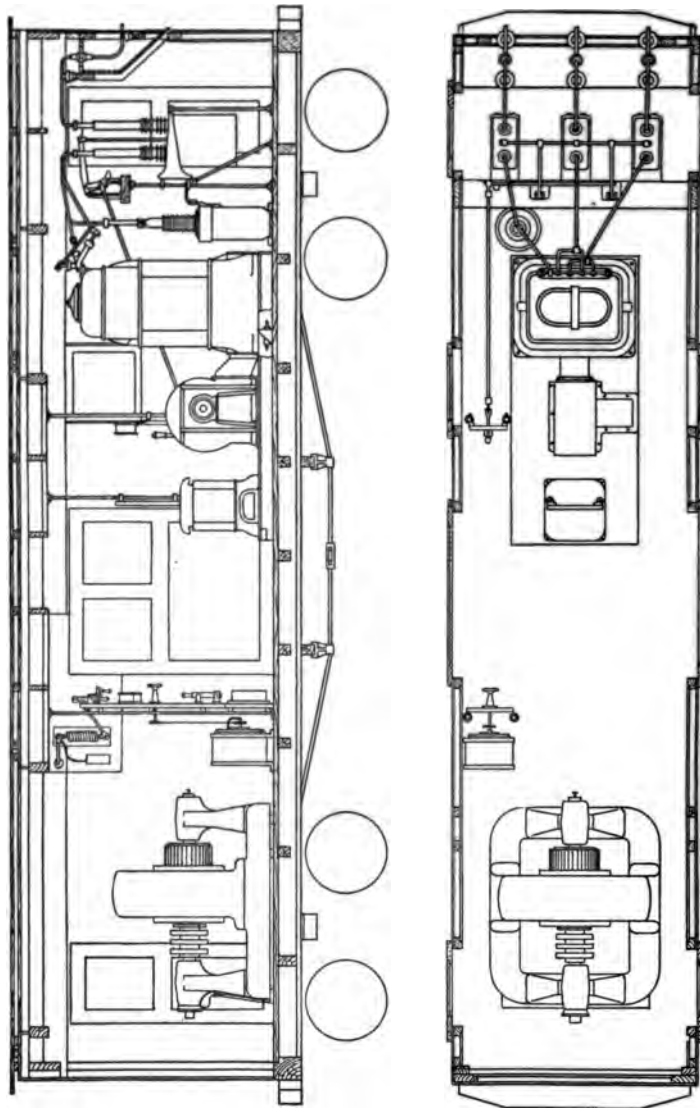

Fig. 86.

PROBLEMS.

37. Derive an expression for the economic spacing of substations, the cross section of the composite contact conductor being prescribed by a mean effective drop of e volts at a point midway between substations.

Suggestion. — Obtain an expression for A by using (3) of § 48, insert it in (3) and (4) of § 62, which then add, multiply by L/λ and use in place of (6) of § 62 for the economic determination.

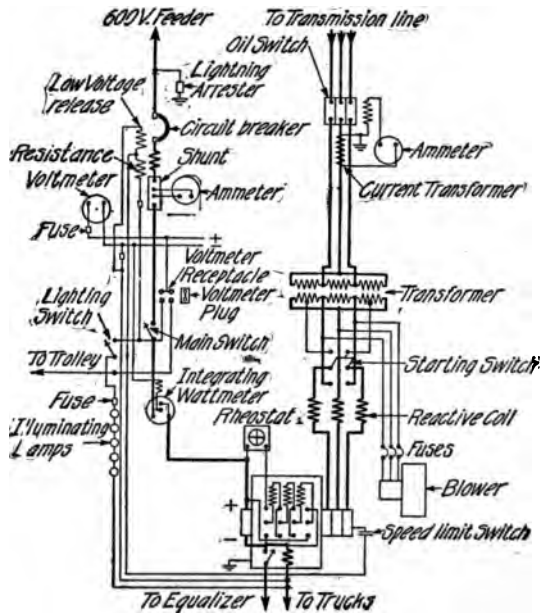

Fig. 87.

38. Assuming the same wages as in the illustration of § 63, what influence would a change of the hours of duty to eight hours a day have upon the spacing?

39. If the road in this illustration were to be operated with single-phase currents and each substation were to be equipped with two single-phase transformers, what would be the economic spacing? Use cost and deficiency constants given in § 62 and neglect reactance drop in the distributing system.

40. If all the equipment in all the substations of the road specified in

§ 63 were to be operated for 8760 hours per year at rated capacity, what would be the value of I_0 and what would be the economic spacing, assuming 1200 as the generator voltage.

41. If the costs of switch gear and lightning arresters for each substation on the road specified in § 63 were to be \$2500 and \$3750 for 250 K.W. and 500 K.W. capacities respectively, what change would thereby be entailed in the cost constants f_3' and g_3' and how would this change affect the value of the economic spacing?

CHAPTER IX.

TRANSMISSION LINES.

67. **Location of the Transmission Line.**— In those installations which employ steam or internal-combustion prime movers in the power station, it is desirable to locate the latter with reference to the substations which it supplies with energy, so that a minimum weight of conductor material shall be required and the drop of voltage to each shall be the same. This location is termed the *center of distribution*. Consider two substations λ feet apart and distant λ_1 and λ_2 feet respectively from an intermediate power station. Assume the substations to be supplied, over a three-phase line, with I_1 and I_2 annual mean effective amperes per wire respectively. If the specific resistance of the conductor material be ρ ohms per circular mil-foot, and the respective cross sections be A_1 and A_2 circular mils, then the power lost in transmitting energy to the substations is $P_1 = 3 \rho \lambda_1 I_1^2 / A_1$ and $P_2 = 3 \rho \lambda_2 I_2^2 / A_2$ watts respectively. If the weight of a circular mil-foot be w pounds, the total weight of conductors is

$$W = 3 w (\lambda_1 A_1 + \lambda_2 A_2) \text{ pounds.}$$

Substituting the values of A_1 , A_2 , and $\lambda_2 = \lambda - \lambda_1$,

$$W = 9 \rho w \left(\frac{\lambda_1^2 I_1^2}{P_1} + \frac{(\lambda^2 - 2 \lambda \lambda_1 + \lambda_1^2) I_2^2}{P_2} \right) \text{ pounds.} \quad (1)$$

For a minimum weight of conductor material, the differential of W with respect to λ_1 must equal zero. Hence

$$\frac{dW}{d\lambda_1} = 18 \rho w \left(\frac{\lambda_1 I_1^2}{P_1} - \frac{\lambda_2 I_2^2}{P_2} + \frac{\lambda_1 I_2^2}{P_2} \right) = 0,$$

or

$$\frac{\lambda_1 I_1^2}{P_1} = \frac{\lambda_2 I_2^2}{P_2}. \quad (2)$$

If the drop to both substations be the same, $P_1/I_1 = P_2/I_2$, and

$$\lambda_1 I_1 = \lambda_2 I_2, \quad (3)$$

wherein λ_1 and λ_2 now represent the respective distances of the substations from the center of distribution. For any number of substations located at various points along a continuous roadway the distance of the center of distribution from any point is $\lambda_0 = \Sigma l / \Sigma I$, each length being measured along the path taken by the transmission line.

The location of the power station at the center of distribution is subject to other considerations, such as the cost of real estate, future growth, facilities for the receipt of fuel and supplies and the removal of ashes, and the availability of water for condensing purposes.

In the case of hydraulic installations, the location of the power station is dependent on the hydraulic conditions, and may be quite distant from the substations. The transmission line should extend from the central station to the nearest substation or to the one nearest the center of distribution, that route being selected which results in the lowest annual cost.

Private rights of way for the transmission line are to be preferred to public highways and generally result in final economy in operation. Rights of way along steam railroads are undesirable because of insulation troubles likely

to result from coal smoke. It is not practical to make the right of way so wide as to prevent a pole or tower from falling on the abutting property, but the right to trim trees on both sides should be secured. A width of from 50 feet to 100 feet is ample. The cost of right of way is from 25 to 50 per cent of the total cost of the transmission line.

68. Number of Phases. — The proper basis for determining the number of phases to be employed is the comparison of the weights of conductor material necessary to transmit the same power, P kilowatts, over the same distance, S feet, with the same loss, P' watts, and the same maximum voltage, E kilovolts, between any two conductors. In a system using n wires each of cross section A circular mils and carrying I amperes the loss is

$$P' = \frac{n\rho SI^2}{A} \text{ watts.} \quad (1)$$

Therefore
$$A = \frac{n\rho SI^2}{P'} \text{ circular mils.} \quad (2)$$

The total weight of the conductors is therefore

$$W = nwAS = \frac{\rho w S^2}{P'} n^2 I^2 \text{ pounds;} \quad (3)$$

that is, the weight is proportional to the square of the product of the number of wires by the current flowing in each wire. The following table is based upon the current per wire in amperes for transmitting, at unit power factor, one kilowatt with a loss of one watt per foot of line at one effective kilovolt between wires of greatest potential difference. With direct currents the equivalent voltage is $\sqrt{2}$ kilovolts. For the three-wire quarter-phase system, where the center conductor carries $\sqrt{2}$ times the current in the outer conductors, it is assumed that the cross sections of

the conductors will be so chosen that the loss per foot is the same, $P'/3$, in each conductor. The maximum voltage between any two conductors is assumed the same in all cases because its value determines the capacity and cost of each insulator. The center wire of the three-wire quarter-phase system, however, does not need to be so well insulated as the outside wires, and to this extent the above comparison is unfair to this system. Considering, however, that the conductor expense considerably exceeds the insulator expense in most cases, this system does not need to be considered in comparison with the three-phase system, which, as shown in the table, is superior to all systems using alternating currents.

RELATIVE WEIGHTS OF CONDUCTORS.

System.	Amperes per Wire.	I^2 .	$\#$ of W.	Relative Total Weight.
Two wires:				
Direct current.....	$I = \frac{P}{\sqrt{2}E} = \frac{1}{\sqrt{2}}$	$\frac{1}{2}$	2	50
Single-phase.....	$I = \frac{P}{E} = 1$	1	4	100
Three wires:				
Three-phase.....	$I = \frac{P}{\sqrt{3}E} = \frac{1}{\sqrt{3}}$	$\frac{1}{3}$	3	75
Quarter-phase:				
Right-hand wire.....	$I = \frac{P/2}{E/\sqrt{2}} = \frac{\sqrt{2}}{2}$	$\frac{1}{2}$	6	150
Center wire.....	$I = \sqrt{2} \frac{P/2}{E/\sqrt{2}} = 1$	1		
Left-hand wire.....	$I = \frac{P/2}{E/\sqrt{2}} = \frac{\sqrt{2}}{2}$	$\frac{1}{2}$		
Four wires:				
Quarter-phase.....	$I = \frac{P/2}{E} = \frac{1}{2}$	$\frac{1}{4}$	4	100

69. Frequency.—The Standardization Rules of the A. I. E. E. give 25 and 60 as standard frequencies. For transmission lines supplying converting substations one or the other should be used. The weights and costs of 60-cycle

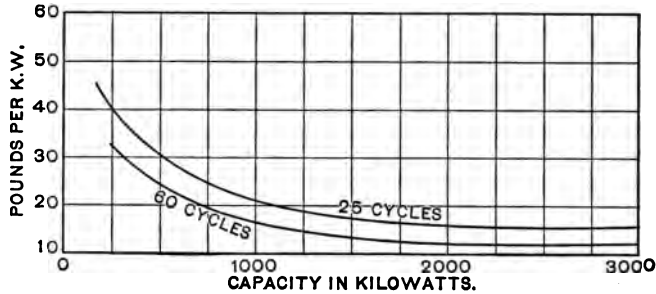

Fig. 88.

transformers are less than those for 25 cycles and the operating efficiencies of the former are greater than those of the latter. The differences are not very great, as will be seen from the curves in Figs. 88 and 89, which refer to

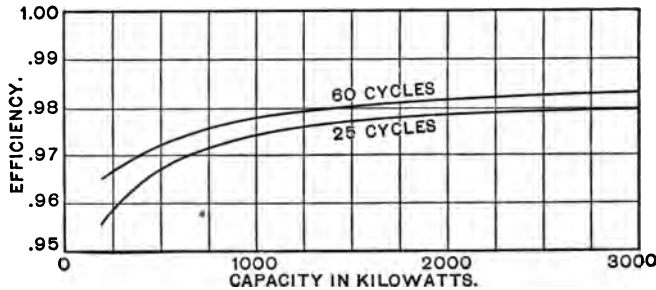

Fig. 89.

33,000-volt, plain steel, air-blast transformers. Induction motors for higher frequencies are also cheaper, but operate at lower power factors. At the lower frequency it is less difficult to operate generators and other synchronous appa-

ratus in parallel, because the unavoidable variations in speed are smaller in proportion to the angular velocity. The charging current of the line and the inductive drop are less with low frequencies, and may give a better regulation. For lines of moderate length it might prove desirable to use 60 cycles, but the general tendency is to use 25 cycles.

For lines of great length, however, it is usually undesirable to use 60 cycles for the following reasons. In all large systems odd harmonic frequencies of voltage and current, of which the third and fifth may predominate, are likely to be present and be superposed upon the fundamental frequency. Electromotive-force harmonics may be due to armature reaction, to pulsation of inductance, to the distribution of armature windings, or to non-uniform distribution of magnetic flux in the air gaps of the generators. Current harmonics may result from similar causes associated with the structures forming the receiving apparatus. Every transmission line, because of its inductance and capacity, has a resonant frequency. The magnetic field of the former and the electric field of the latter serve for the storage of energy in kinetic and potential forms respectively. Such capacities for the storage of the two forms of energy are characteristic of every medium for wave propagation, and their magnitudes determine the velocity of the propagation. As will be shown later, the velocity with which an impressed difference of potential travels away from a generator along a line of usual construction is but slightly less than the velocity of light, that is, in the neighborhood of 186,000 miles per second. Now a transmission line with both ends open or both ends short-circuited has a resonant frequency which corresponds to a wave length equal to twice the length of the line, as is the case with an organ pipe open at both ends.

On the other hand its length is but a quarter wave length when one end is open and the other short-circuited, as is the case with a closed organ pipe. In the latter condition a line 155 miles long would correspond to a wave length of $4 \times 155 = 620$ miles and the corresponding resonant frequency would be 186,000 miles per second divided by 620 miles, or 300 per second, which is the frequency of the fifth harmonic, when the fundamental is 60 cycles per second. The use of 60 cycles on a line of such length is therefore likely to result in resonant oscillations of current and electromotive force which may prove disastrous.

For the operation of single-phase railroads a frequency of less than twenty-five permits of a marked reduction in the size of a motor for a given output; and yet almost all such roads have adopted 25 cycles. The New York, New Haven & Hartford Railroad is an instance. The Midi Railway of France, among others, has adopted 15 cycles. A determination of the most suitable frequency for such installations is desirable, involves extensive knowledge as to costs and peculiarities in operation, and must be considered as to its bearing on the general question of the standardization of practice.

70. Economic Voltage. — The economic voltage between the wires of a transmission line depends upon the amount of power and the distance over which it is to be transmitted as well as upon the various cost factors of equipment and energy. To understand the method for its determination and to avoid complexity, assume a single three-phase line of equivalent length S feet supplying at a maximum P kilowatts, divided equally among n substations, each of which contains two converter units of rated capacity $P/2n$ kilowatts. Assume further that the rated capacity of each of

the three single-phase step-up transformers at the power station is $P/3$ kilowatts.

Conductor Expense. — If the yearly mean effective power factor be $\cos \phi$ and the voltage between wires be E kilovolts, the full load current per wire will be

$$I = \frac{P}{\sqrt{3} E \cos \phi} \text{ amperes.}$$

If the resistance of a mil-foot of conductor be ρ ohms, the resistance of each wire will be $\rho S/A$ ohms, and if the equivalent effective yearly hours of operation on full load current be h , the annual loss of energy in all three wires will be

$$\frac{3 RI^2 h}{1000} = \frac{\rho h S P^2}{1000 A E^2 \cos^2 \phi} \text{ kilowatt hours.}$$

If the mean annual cost of delivering a kilowatt hour to the middle of the line be c_3 dollars, the annual expense for energy lost in the line conductors will be

$$C_c' = \frac{c_3 \rho h S P^2}{1000 A E^2 \cos^2 \phi} \text{ dollars.} \quad (1)$$

If w be the weight of a mil-foot in pounds, c_2 be the cost per pound, and p_2 be the rate of interest and depreciation on the cost of conductors, the annual charge on the capital outlay for all three conductors is

$$C_c'' = 3 p_2 c_2 w S A \text{ dollars.} \quad (2)$$

Since equations (1) and (2) must be equal to each other for a minimum annual cost, they may be equated and solved for A , giving

$$A = \frac{P}{E \cos \phi} \sqrt{\frac{c_3 \rho h}{3000 p_2 c_2 w}} \text{ circular mils.} \quad (3)$$

Substituting this value of A in (2) and multiplying by 2 so as to include (1), the total annual charge against the conductors will be

$$C_c = C_c' + C_c'' = \left[\frac{0.1096 PS}{\cos \phi} \sqrt{c_3 \rho h p_2 c_2 w} \right] \frac{1}{E} \text{ dollars,} \quad (4)$$

and representing the bracketed expression by K_c ,

$$C_c = K_c/E \text{ dollars.} \quad (5)$$

Pole and Insulator Expense. — There are several standard forms of construction of towers or poles. Many rigid steel towers have been installed and recently flexible steel structures costing materially less than those of the rigid type have been used with success. The determination of the type to be employed can best be made in connection with a specific problem, which determination will also give the economic distance, λ' feet, between poles. With poles of the flexible type the cost, c_p , does not materially vary with the voltage between the line wires. Furthermore, if insulators of the suspension type be employed, the cost of each one per kilovolt, c_i , is practically constant. Since the number of poles to be used on a line of real length S' equals S'/λ' and the number of insulators is three times this, if the annual interest and depreciation on these items be p_p and p_i respectively, the annual pole and insulator expense is

$$C_p = [p_p c_p S'/\lambda'] + [3 p_i c_i S'/\lambda'] E \text{ dollars,} \quad (6)$$

and, representing the bracketed expressions by K_p and K_p' respectively,

$$C_p = K_p + K_p' E \text{ dollars.} \quad (7)$$

Pin-type insulators cost more per kilovolt as the operating voltage increases. It is assumed by some that the cost thereof increases as the cube of the voltage.

Transformer Expense. The costs of transformers depend not only upon their rated capacity but also upon the voltage at the high-tension terminals. The insulation expense increases with voltage. For the same capacity and voltage water-cooled transformers are cheaper than air-cooled ones. Power-station facilities are generally such as to permit the use of water-cooled step-up transformers, while air-blast transformers are common in substations. A study of the prices for transformers shows that the cost of each, c_t , can be expressed by the following formula, where E represents the high-tension kilovoltage, P_1 the rated capacity in kilowatts, and K and K' are constants:

$$c_t = (KE + K') \sqrt{P_1} \text{ dollars.} \quad (8)$$

This formula applied to transformers where P_1 varies from 500 to 4000 and E from 22 to 66, gives results within the variations between the quotations from different manufacturing companies. It is approximately true also for higher voltages. In a particular problem with many substations it would be wise to make use of two sets of values for the constants applying respectively to the power and substation transformers.

The number of transformers in the power station is three; each of capacity $P/3$ kilowatts. There are $6n$ in the n substations; each of capacity $P/6n$ kilowatts. If p_t be the rate of interest and depreciation on this apparatus, the annual expense for transformers in dollars is

$$C_t = 3 p_t (KE + K') \sqrt{P/3} + 6 p_t n (KE + K') \sqrt{P/6n},$$

which by combining and transposing becomes

$$C_t = [3 p_t K' \sqrt{P/3} (1 + \sqrt{2n})] + [3 p_t K \sqrt{P/3} (1 + \sqrt{2n})] E \quad (9)$$

and, if K_t and K_t' represent the bracketed expressions, the annual transformer expense may be represented as

$$C_t = K_t + K_t'E \text{ dollars.} \quad (10)$$

Auxiliary Expense.—The costs of aluminum lightning arresters, choke coils, and oil switches increase with the voltage of the circuits with which they are to be connected. The first mentioned increase more rapidly than the voltage, the second nearly directly, and the last less rapidly. If their combined costs for different voltages be determined, it will be found that the cost per three-phase unit may be expressed, with sufficient accuracy, as a linear function of the voltage. Considering a unit to consist of a four-tank arrester, three choke coils, and a triple-pole oil switch, and one unit to be installed in each substation and in the power station, if c_a be the cost per unit per kilovolt and p_a be the rate of interest and depreciation, the annual expense chargeable to these auxiliaries will be

$$C_a = [p_a c_a (n + 1)] E, \quad (11)$$

and representing the bracketed expression by K_a ,

$$C_a = K_a E \text{ dollars.} \quad (12)$$

Solution. The economic voltage is now determined by adding the expressions for the annual expenses for conductors, poles, insulators, transformers, and auxiliaries, differentiating the sum with respect to E , equating to zero and then solving for E as follows:

$$C = C_c + C_p + C_t + C_a,$$

$$C = (K_p + K_t) + K_c/E + (K_p' + K_t' + K_a)E \text{ dollars,} \quad (13)$$

$$\frac{dC}{dE} = -K_c/E^2 + (K_p' + K_t' + K_a) = 0.$$

Therefore the economic voltage between wires is

$$E = \sqrt{\frac{K_r}{K_p' + K_t' + K_s}} \text{ kilovolts.} \quad (14)$$

Substituting the values of the constants from equations (4), (6), (9), and (11),

$$E = \sqrt{\frac{(0.1096 PS/\cos \phi) \sqrt{c_2 \rho h p_2 c_2 w}}{3 p_i c_i S' / \lambda' + 3 p_i K \sqrt{P/3} (1 + \sqrt{2n}) + p_a c_a (n + 1)}} \text{ kilovolts,} \quad (15)$$

and the economic cross section of the conductors is found by inserting this value in equation (3).

In the above derivation the total transformer capacity at the power station has been assumed equal to that in all substations. In existing plants the latter exceeds the former by from 40 per cent to 60 per cent. This is feasible when the load peaks of the different substations are not simultaneous. The ratio of the maximum load supplied at one time to all substations to the sum of the maximum loads on each substation is termed the *diversity factor*. Furthermore, it has been assumed that the power factor at maximum load is unity. This can be realized as resulting from the phase of the currents taken by converters at maximum load when the voltage regulation is that produced by reactances. The converters then tend to correct the power factor of the line. The energy given to the line at the power station must, however, exceed that which is delivered to the substations by the amount which is lost in the transmission line.

Generally a transmission line extends from the power station to one of several substations, then divides, and continues to the other substations. The currents in the branch

conductors are less than in the conductors of the main line and the cross section is accordingly reduced. The economic cross section of a conductor of a branch, of length S_B feet between substations, is determined by equation (3) and the total annual charge against the conductors by equation (4). If the mean annual effective power factor on the branch be the same as on the main line, then the main line may be considered as having added to it a length S_E such that the annual conductor expense for the branch is included in that for the main line. Remembering that $I = P/\sqrt{3} E \cos \phi$, and equating two expressions like equation (4), applied to lengths S_B and S_E and to currents I_B and I respectively,

$$I_B S_B = I S_E,$$

whence

$$S_E = S_B I_B / I. \quad (16)$$

If the distance from the power station to the first substation be S_O feet, then the *equivalent length* to be used in calculating the annual expense of conductors is

$$S = S_O + \Sigma S_E, \quad (17)$$

the last term including the extension of length due to all branches.

In calculating the annual expense against insulators and poles, however, the real length of the complete line must be taken.

71. Numerical Illustration. — Assume a single three-phase 25-cycle line having an equivalent length of $S = 350,000$ feet and a real length of $S' = 450,000$ feet, transmitting, at maximum rated load, $P = 3000$ kilowatts divided equally among $n = 5$ substations at the receiving end of the line. Let the annual effective power factor be $\cos \phi = 0.90$, the equivalent annual hours of operation be

$h = 3500$, and let the constants have the following values — the bracketed values being suggestive of the proper order of magnitude:

$$\begin{array}{ll} \rho = 10. & c_p = [80]. \\ w = 0.00000303. & \lambda' = [600]. \\ p_2 = [0.06]. & c_t = [0.20]. \\ c_2 = [0.18]. & K = [0.50]. \\ c_3 = [0.01]. & K' = [65]. \\ p_i = p_p = p_t = p_a = [0.12]. & c_a = [50]. \end{array}$$

Substituting these values,

$$\begin{aligned} K_c &= (0.1096 \times 3000 \times 350,000/0.9), \\ &\sqrt{.01 \times 10 \times 3500 \times .06 \times .18 \times 0.00000303} = 432,000, \\ K_p' &= 3 \times 0.12 \times 0.2 \times 450,000/600 = 54, \\ K_t' &= 3 \times 0.12 \times 0.5 \sqrt{1000} (1 + \sqrt{10}) = 23.75, \\ K_a &= 0.12 \times 50 \times 6 = 36. \end{aligned}$$

Substituting these values in equation (14), the economic voltage is

$$E = \sqrt{\frac{432,000}{54 + 23.75 + 36}} = 61.7 \text{ kilovolts.}$$

The American Institute of Electrical Engineers recommends as standard voltages for transmission circuits 6.6, 11, 22, 33, 44, 66, or 88 kilovolts. Furthermore, 55-kilovolt apparatus is listed by manufacturers. The problem in hand requires for greatest economy 61.7 kilovolts, a value which falls between two of those recommended. It is instructive to find what additional annual expense would be entailed in following the recommendations. The annual expense items for different voltages are therefore given in the following table.

ANNUAL EXPENSES AT DIFFERENT VOLTAGES.

Items of Annual Expense.	Kilovolts between Wires.			
	44	55	61.7	66
Conductors:				
K_c/E	9,810	7,860	7,010	6,550
Poles and insulators:				
K_p	7,200	7,200	7,200	7,200
$K_p'E$	2,378	2,970	3,330	3,560
Transformers:				
K_t	4,050	4,050	4,050	4,050
$K_t'E$	1,044	1,314	1,467	1,568
Auxiliaries:				
K_aE	1,582	1,980	2,220	2,376
Total annual expense.....	\$25,094	\$24,404	\$24,307	\$24,334

These results show that the additional annual expense would be but \$97 at 55 kilovolts or \$27 at 66 kilovolts, and therefore either standard voltage should be adopted. The use of the higher voltage requires a somewhat smaller initial investment. It may be desirable in some cases materially to increase the operating voltage above that determined in this manner, in order to limit the first cost.

72. Separation of Conductors. — The proper separation of the conductors of a transmission line depends largely upon the insulating properties of the atmosphere. If the voltage between two aerial conductors be gradually increased a *critical voltage* is reached at which a discharge of electricity from the conductors into the air is initiated. This critical voltage depends upon the sizes of the conductors and the distance between them, and upon the temperature and pressure of the air. When this voltage is exceeded, the conductors when seen at night are surrounded by a luminous envelope of red-violet color. The phenomenon is termed *corona*. A considerable loss of

energy results from the employment of transmission voltages above the critical value, this loss being termed *corona loss*.

At normal pressure and temperature, the air breaks down and becomes convectively conductive when subjected to a *uniform* electric field strength of 78 kilovolts per inch or 31 kilovolts per centimeter. For alternating currents these values apply to the maximum value of the voltage wave, therefore, if a sine wave is assumed the strength of air is $31 \div \sqrt{2}$ or 21.9 effective kilovolts per centimeter. The electric fields in the vicinity of the conductors of an ordinary aerial line are not uniform, for the lines of electrostatic flux diverge in leaving the conductors. The amount of diver-

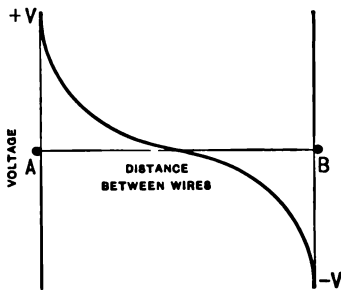

Fig. 90.

gence depends upon the sizes of the conductors and the distance between them. The distribution of potential between two wires, *A* and *B*, is typified by Fig. 90. The strength of the electric field at any point between the conductors is measured by the slope of the curve at that point, and is termed the *voltage gradient*.

This gradient, expressed in volts (or kilovolts) per centimeter, is seen to be greatest at the wire surface and least midway between the wires. In consequence, it is at the surface of the wires where the breakdown of the air must first occur, and therefore the electrical conditions for the starting of corona may be determined from the critical field intensity at the surface of the conductor.

The physical process underlying the initiation of corona is termed *ionization by collision*. Due primarily to the

presence of radioactive substances on the earth, there are always present in the atmosphere positive and negative *ions*, each carrying a charge of 4.6×10^{-10} abstat coulombs or multiples thereof. Under ordinary conditions the number present per cubic centimeter is of the order of 1000, and this number is inadequate to permit of appreciable convective conduction by the air of the problem under consideration. Each of these ions however, if subjected to an electric field intensity of sufficient magnitude, will acquire adequate kinetic energy in traversing a free path, to *ionize* a neutral air molecule with which it collides. The energy required to ionize a gas particle, as determined by various methods, is of the order 4×10^{-11} ergs. Since the free path of a gas particle increases directly with decrease of pressure at constant temperature and with increase of temperature at constant pressure, the value of the critical voltage will accordingly decrease with like proportionality.

Numerous experiments show that the voltage gradient (maximum value in the case of alternating currents) at the surface of the wire when corona appears on a round wire located in air depends upon the diameter of the wire and the density of the air in a manner given by Peek's equation

$$g = A\delta + B\sqrt{\frac{\delta}{D}} \text{ kilovolts per cm.}, \quad (1)$$

where D is the diameter of the wire in cm., A and B are constants, and δ is a density factor. The value of this density factor is unity at a barometric pressure of 76 cm. of Hg. and a temperature of 25° C., while for any other pressure p cm. and other temperature t° C. its value is

$$\delta = \frac{p}{76} \cdot \frac{273 + 25}{273 + t} = \frac{3.92 p}{273 + t}. \quad (2)$$

The values of the constants A and B in equation (1) obtained by various observers are somewhat at variance with each other, due probably to difficulties in measuring the ratio of the maximum to the effective values of the high alternating voltages and to the dissimilar surface conditions of the wires tested. Recent tests by Prof. J. B. Whitehead on wires ranging from 0.074 to 0.231 cm. diameter yield the following values for A and B :

		A	B
Alternating current		33.7	12.6
Continuous current	wire positive	33.7	11.5
	wire negative	31.02	13.5

F. W. Peek uses as his most recent coefficients corresponding to A and B for alternating currents the following:

$$A = 31.0 \quad \text{and} \quad B = 13.5.$$

The usual experimental method for ascertaining the value of the critical surface gradient g is to apply a high voltage between a wire and a metal tube, which tube is placed coaxially around the wire. If the wire has a diameter D cm. and the tube a radius of b cm., and corona appears when the applied voltage has reached a maximum value of V kilovolts, then the critical voltage gradient at the wire surface is given by

$$g = \frac{2V}{D \log_e \frac{2b}{D}} \text{ kilovolts per cm.} \quad (3)$$

Prof. Bennett calls this the *hypothetical gradient* because it holds for pure dielectrics permitting of elastic displacement only, but does not necessarily hold for dielectrics at potentials causing corona around the wire. Corona produced by alternating currents may be detected by visibility

or by an electroscope, while for direct-current corona a galvanometer may be used as an additional method. In a particular experiment by Whitehead, a wire of 0.231 cm. diameter within a tube 6.109 cm. in diameter required 22,500 volts (maximum value of alternating voltage) for

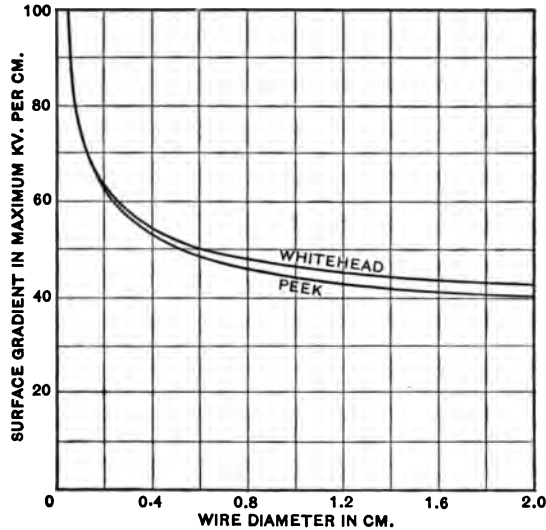

Fig. 91.

the appearance of corona; the critical surface intensity from equation (3) is therefore

$$g = \frac{2 \times 22.5}{0.231 \times 2.3026 \log_{10} \frac{6.109}{0.231}} = 59.6 \text{ kilovolts per cm.}$$

Having experimentally determined the values of g in this way for various values of wire diameter D and of density factor δ , the numerical magnitudes of the constants A and B of equation (1) are then ascertained.

The critical surface gradients for various sized conductors are given in Fig. 91 as calculated from equation (1), using the alternating-current constants A and B as given by Peek and Whitehead and taking $\delta = 1$. The curves are practically coincident over the range of Whitehead's experiments, but separate beyond a conductor diameter of 0.2 cm.

The gradient at the surface of a wire of diameter D cm. within a conducting cylinder of radius b cm. with a voltage V across the wire and cylinder is the same as the surface gradient of the same wire when used as one of parallel wires if the voltage from wires to neutral is equal to V and the distance d from center to center of the wires is equal to b . Then, from equation (3), the gradient for the appearance of corona on parallel wires is

$$g = \frac{2V}{D \log_e \frac{2d}{D}} \text{ kilovolts per cm.}, \quad (4)$$

where V is the voltage from a wire to neutral in kilovolts (maximum value) and d is the conductor separation in cm. Solving this expression for V and using equation (1) there results as the visual critical voltage to neutral:

$$V = \frac{gD}{2} \log_e \frac{2d}{D} = \frac{D}{2} \left(A\delta + B\sqrt{\frac{\delta}{D}} \right) \log_e \frac{2d}{D} \text{ kilovolts.} \quad (5)$$

To take care of the condition of the conductor surface, an irregularity factor m should be inserted in the foregoing equation. Its value is given by Peek as follows:

Polished solid conductors	1.00
Roughened or weathered wires	0.98 to 0.93
Cables (seven strand)	0.82 to 0.72

Converting equation (5) to effective voltage to neutral by dividing by $\sqrt{2}$, reducing the logarithm to base 10, and

using $A = 31.0$ and $B = 13.5$, there results as the *effective* voltage at which corona becomes visible:

$$V = mD \left(25.2 \delta + 11.0 \sqrt{\frac{\delta}{D}} \right) \log_{10} \frac{2d}{D} \text{ kilovolts. } (6)$$

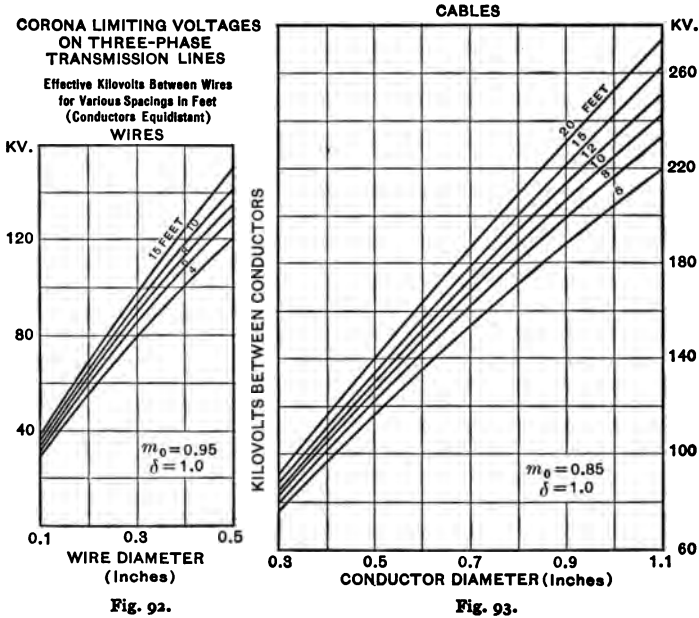

A loss of power from transmission lines occurs at a voltage lower than that at which corona appears, the difference being considerable with small wires. This voltage, termed the *disruptive critical voltage*, is expressed by the following equation given by Peek and similar in form to equation (5):

$$E_{cr} = g_0 m_0 \frac{D}{2} \delta \log_e \frac{2d}{D} \text{ kilovolts to neutral, } (7)$$

where g_0 is the disruptive voltage gradient at the conductor surface and may be taken as 21.9 kilovolts (effective value)

per centimeter, and m_0 is the irregularity factor which is the same as m for wires but has values between 0.87 and 0.83 for cables. The critical voltage between conductors is $\sqrt{3}$ times the value of E_{cr} for three-phase lines and twice E_{cr} for single-phase lines. The critical voltage is lowered by smoke, fog, sleet, rain and snow, but is not appreciably affected by humidity, air velocity or wire material.

The disruptive critical voltages between conductors (triangularly spaced) on three-phase lines are shown by the curves in Fig. 92 for solid wires and in Fig. 93 for cabled conductors, plotted from equation (7). When the three wires lie symmetrically in one plane the critical voltage for the center wire will be about 4 per cent lower, and for the outer wires 6 per cent higher than shown.

73. Resistance of Conductors.—The resistance per mile of length of a conductor in which the current density is uniform throughout the cross section, A circular mils, at any temperature t degrees centigrade is

$$R_c = 5280 \frac{\rho}{A} (1 + at),$$

where ρ is the resistivity in ohms per circular mil-foot at 0 degrees centigrade, and a is the mean temperature coefficient of electrical resistance; accepted values of which for the usual line materials being

	ρ	a	w
Copper (hard drawn)	9.54	0.00415	0.00000303
Aluminum (hard drawn)	15.8	0.0039	0.00000091

The weights per circular mil-foot in pounds of copper and aluminum are given in the last column.

Uniform distribution of current in conductors is realized in the transmission of continuous currents. In conductors

carrying alternating currents, the current density at the surface is greater than at the axis of the conductors; this unequal distribution of current increases with the frequency of the impressed electromotive force and manifests itself as an increase in resistance by rendering part of the conductor cross section ineffective. Fig. 94 shows the per-

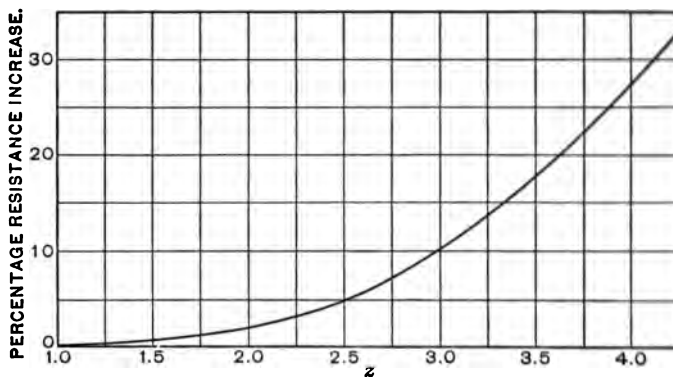

Fig. 94.

centage increase of resistance of conductors when traversed by alternating currents over that when traversed by continuous currents in terms of a function z , which is defined as

$$z = r \sqrt{\frac{f}{\rho}},$$

where r is the radius of the wire in inches and f is the frequency in cycles per second.

The resistances per unit length of cables are somewhat greater than those of solid conductors of like cross-sectional areas. If there be N strands in a cable having a lay of r in n (i.e., the pitch of the strand helices is n times their diameter measured along the central wire), the total re-

sistance of the cable, assuming no current flow between strands, will be

$$R = R_c \frac{N}{1 + \frac{n(N-1)}{\sqrt{\pi^2 + n^2}}}$$

Thus, the resistance of a 19-strand cable having a lay of 1 in 15 is 2.05 per cent greater than the resistance of a solid conductor of equal cross-sectional area.

74. Line Inductance.— Conductors carrying a varying current are surrounded by a magnetic field of varying intensity. A change in the magnetic flux which encircles a conductor develops in it an electromotive force of self-induction. If the conductors carry an alternating current an alternating electromotive force will be induced in them, the magnitude of which depends upon the time rate of change of current, that is, its value at the instant t is $L \frac{dI'}{dt}$, where L represents the inductance of the circuit and I' is the instantaneous current value.

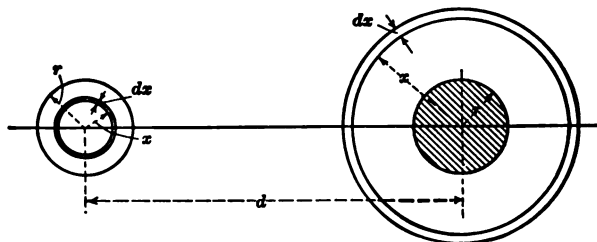

Fig. 95.

To determine the inductance L per unit length of single wire, consider a two-wire line carrying an alternating current, the conductors being of radius r and separated between centers by a distance d , as shown in Fig. 95. The

magnetic flux which passes through an element outside of the conductor of width dx and of unit axial length is equal to the magnetomotive force divided by the reluctance, or

$$d\Phi_1 = \frac{4 \pi i}{2 \pi x} = 2 i \frac{dx}{x},$$

where i is the instantaneous value of the current flowing in the conductors. The total magnetic flux which passes between the wires due to the current in one of them is obtained by integration for values of x between $d - r$ and r , as

$$\Phi_1 = 2 i \int_r^{d-r} \frac{dx}{x} = 2 i \log_e \frac{d-r}{r},$$

d and r being both expressed in terms of the same unit.

The magnetic flux which passes through the conductor material is of appreciable magnitude owing to the greater flux density near the wires. Assuming for simplicity that the current is uniformly distributed over the cross sections of the cylindrical conductors, then the current inside the circle of radius x is $\frac{x^2}{r^2} i$, and the magnetomotive force which it produces is $4 \pi \frac{x^2}{r^2} i$. The magnetic flux per unit length of the element dx is $2 i \mu \frac{x dx}{r^2}$, and since this flux is associated with but $\frac{x^2}{r^2}$ ths of the wire, the equivalent elementary magnetic flux which may be considered as linking the entire conductor is

$$d\Phi_2 = 2 i \mu \frac{x^3 dx}{r^4}.$$

Integrating for values of x between 0 and r , there results

$$\Phi_2 = \frac{1}{2} i \mu.$$

Hence the total magnetic flux linked with each conductor of the two-wire line is

$$\Phi_1 + \Phi_2 = i \left[2 \log_e \frac{d-r}{r} + \frac{\mu}{2} \right],$$

and therefore the inductance per centimeter length of the straight conductors, being the flux per unit current, in absolute units is

$$l = 2 \log_e \frac{d-r}{r} + \frac{\mu}{2} \text{ centimeters.}$$

By reduction, the inductance per mile for a single copper or aluminum wire becomes

$$L = \left[741 \log_{10} \frac{d-r}{r} + 80.5 \right] 10^{-8} \text{ henries.}$$

For 19-strand and 7-strand cables the constant 80.5 should be replaced by 89 and 102 respectively.

75. Hyperbolic Functions. — Many numerical calculations in Electrical Engineering are greatly facilitated by the use of hyperbolic functions, just as are calculations in mechanics by the use of circular functions. The use of the former is as simple as that of the latter and the relations which exist between the functions of each type are almost identical, the transformation formulæ seldom differing from each other in more than sign. Hyperbolic functions are especially useful in treating the problems arising in connection with transmission lines.

In Fig. 96 consider the rectangular hyperbola HH and the circle CC concentric with O as a center. Since OA equals the radius, r , of the circle, y_c/OA is the circular sine of the angle θ by conventional definition. Similarly y_h/OA is, by definition, the hyperbolic sine, or, as it is commonly expressed, the *sinh* of the corresponding magnitude. Although the circular functions are usually specified in terms

of the angle, θ , included between the axis of abscissæ and the radius vector through any point, P_c , of the circle, they might equally as well be specified by twice the area AOP_c of the circular sector which corresponds with this angle, if the

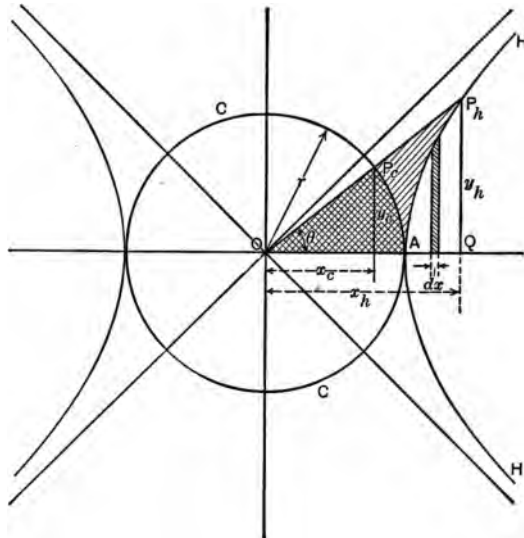

Fig. 96.

radius were unity. This will become evident if it be considered that the circular sectorial area $u_c = \frac{\theta}{2\pi} \pi r^2$, whence

$\theta = \frac{2}{r^2} u_c$; that is, θ varies directly with u_c . The hyperbolic

functions are not specified by the angle θ but by twice the hyperbolic sectorial area $AOP_h = u_h$. Referring to a circle of unit radius, by definition $x_c/OA = \cos \theta = \cos 2u_c$ and $y_c/x_c = \tan 2u_c$; similarly $x_h/OA = \cosh 2u_h$ and $y_h/x_h = \tanh 2u_h$, the final h signifying hyperbolic functions.

The relations which exist between the coördinates of any

point, P_h , on the hyperbola and the corresponding sectorial area u_h may be derived from the equation of the equilateral hyperbola, $x^2 - y^2 = r^2$. The area of the sector OAP_h is

$$u_h = \text{area of triangle } OQP_h - \text{area of segment } AQP_h$$

$$\begin{aligned} \text{or} \quad u_h &= \frac{x_h y_h}{2} - \int_r^{x_h} y \, dx \\ &= \frac{x_h y_h}{2} - \int_r^{x_h} \sqrt{x^2 - r^2} \, dx \\ &= \frac{r^2}{2} \log_e \frac{x_h + y_h}{r}. \end{aligned}$$

$$\text{Therefore} \quad \frac{x_h + y_h}{r} = \epsilon^{\frac{2u_h}{r^2}}. \quad (1)$$

Since the equation of the hyperbola may be written as

$$r^2 = (x + y)(x - y),$$

whence

$$\begin{aligned} \frac{x + y}{r} &= \frac{r}{x - y}, \\ \frac{x_h - y_h}{r} &= \epsilon^{-\frac{2u_h}{r^2}} \end{aligned} \quad (2)$$

By adding (1) and (2)

$$\frac{x_h}{r} = \frac{1}{2} \left(\epsilon^{\frac{2u_h}{r^2}} + \epsilon^{-\frac{2u_h}{r^2}} \right). \quad (3)$$

In general, dropping the subscript of x , making the radius

$$r = 1, \text{ and letting } u = \frac{2u_h}{r^2},$$

$$x = \frac{1}{2} (\epsilon^u + \epsilon^{-u}) = \cosh u. \quad (4)$$

By subtracting (2) from (1) and expressing in general form

$$y = \frac{1}{2} (\epsilon^u - \epsilon^{-u}) = \sinh u, \quad (5)$$

and dividing (5) by (4),

$$\frac{y}{x} = \frac{\sinh u}{\cosh u} = \tanh u. \quad (6)$$

The ratio of the areas, $u = 2 u_h/r^2$, is termed the *argument*, which specifies the functions.

For large values of u the second exponential terms in equations (4) and (5) vanish and $\sinh u = \cosh u$ while $\tanh u = 1$.

Relations between the Functions.— The following useful formulæ, showing some of the relations existing between the hyperbolic functions, may be derived readily from the properties of the hyperbola or by substitution or transformation.

$$\cosh^2 u - \sinh^2 u = 1. \quad (7)$$

$$\sinh (u \pm v) = \sinh u \cosh v \pm \cosh u \sinh v. \quad (8)$$

$$\cosh (u \pm v) = \cosh u \cosh v \pm \sinh u \sinh v. \quad (9)$$

$$\sinh 2u = 2 \sinh u \cosh u. \quad (10)$$

$$\cosh 2u = \cosh^2 u + \sinh^2 u. \quad (11)$$

$$\cosh u \pm \sinh u = e^{\pm u}. \quad (12)$$

Differential Coefficients.— By successively differentiating equations (4) and (5) there results

$$\frac{d \sinh u}{du} = \frac{e^u + e^{-u}}{2} = \cosh u; \quad \frac{d^2 \sinh u}{du^2} = \sinh u, \quad (13)$$

$$\frac{d \cosh u}{du} = \frac{e^u - e^{-u}}{2} = \sinh u; \quad \frac{d^2 \cosh u}{du^2} = \cosh u. \quad (14)$$

This repetition of the functions, after two successive differentiations, is the basis of their utility in problems of decay or attenuation.

Tables.— An excellent set of tables and formulas relating to this subject is published by the Smithsonian Institution of Washington in Publication No. 1871 bearing the title "Hyperbolic Functions." The numerical values of \cosh and \sinh for arguments from 0.00 to 8.45 are given in the following table.

HYPERBOLIC FUNCTIONS.

n.	sinh n.	cosh n.	n.	sinh n.	cosh n.	n.	sinh n.	cosh n.
0.00	0.0000	1.0000	0.50	0.5211	1.1276	1.00	1.1752	1.5431
01	0100	0001	51	5324	1329	05	2539	6038
02	0200	0002	52	5438	1383	10	3356	6685
03	0300	0005	53	5552	1438	15	4208	7374
04	0400	0008	54	5666	1494	20	5095	8107
05	0500	0013	55	5782	1551	25	6019	8884
06	0600	0018	56	5897	1609	30	6984	1.9709
07	0701	0025	57	6014	1669	35	7991	2.0583
08	0801	0032	58	6131	1730	40	1.9043	1509
09	0901	0041	59	6248	1792	45	2.0143	2488
10	1002	0050	60	6367	1855	50	1293	3524
11	1102	0061	61	6485	1919	55	2496	4619
12	1203	0072	62	6605	1984	60	3756	5775
13	1304	0085	63	6725	2051	65	5075	6995
14	1405	0098	64	6846	2119	70	6456	8283
15	1506	0113	65	6967	2188	75	7904	2.9642
16	1607	0128	66	7090	2258	80	2.9422	3.1075
17	1708	0145	67	7213	2330	85	3.1013	2585
18	1810	0162	68	7336	2402	90	2682	4177
19	1911	0181	69	7461	2476	95	4432	5855
20	2013	0201	70	7586	2552	2.00	6269	7622
21	2115	0221	71	7712	2628	05	3.8196	3.9483
22	2218	0243	72	7838	2706	10	4.0219	4.1443
23	2320	0266	73	7966	2785	15	2342	3597
24	2423	0289	74	8094	2865	20	4571	5679
25	2526	0314	75	8223	2947	25	6912	4.7966
26	2629	0340	76	8353	3030	30	4.9370	5.0372
27	2733	0367	77	8484	3114	35	5.1951	2905
28	2837	0395	78	8615	3199	40	4662	5569
29	2941	0423	79	8748	3286	45	5.7510	5.8373
30	3045	0453	80	8881	3374	50	6.0502	6.1323
31	3150	0484	81	9015	3464	55	3645	4426
32	3255	0516	82	9150	3555	60	6.6947	6.7690
33	3360	0549	83	9286	3647	65	7.0417	7.1123
34	3466	0584	84	9423	3740	70	4063	4735
35	3572	0619	85	9561	3835	75	7.7894	7.8533
36	3678	0655	86	9700	3932	80	8.1919	8.2527
37	3785	0692	87	9840	4029	85	8.6150	8.6728
38	3892	0731	88	0.9981	4128	90	9.0596	9.1146
39	4000	0770	89	1.0122	4229	95	9.5268	9.5791
40	4108	0811	90	0265	4331	3.00	10.0179	10.0677
41	4216	0852	91	0409	4434	05	10.5340	10.5814
42	4325	0895	92	0554	4539	10	11.0765	11.1215
43	4434	0939	93	0700	4645	15	11.6466	11.6895
44	4543	0984	94	0847	4753	20	12.2459	12.2866
45	4653	1030	95	0995	4862	25	12.8758	12.9146
46	4764	1077	96	1144	4973	30	13.5379	13.5748
47	4875	1125	97	1294	5085	35	14.2338	14.2689
48	4986	1174	98	1446	5199	40	14.9654	14.9987
49	5098	1225	99	1598	5314	45	15.7343	15.7661

HYPERBOLIC FUNCTIONS.

u.	sinh u.	cosh u.	u.	sinh u.	cosh u.
3.50	16.5426	16.5728	6.00	201.7132	201.7156
55	17.3923	17.4210	05	212.0553	212.0577
60	18.2855	18.3128	10	222.9278	222.9300
65	19.2243	19.2503	15	234.3576	234.3598
70	20.2113	20.2360	20	246.3735	246.3755
75	21.2488	21.2723	25	259.0054	259.0074
80	22.3394	22.3618	30	272.2850	272.2869
85	23.4859	23.5072	35	286.2455	286.2472
90	24.6911	24.7113	40	300.9217	300.9233
3.95	25.9581	25.9773	45	316.3504	316.3520
4.00	27.2899	27.3082	50	332.5700	332.5716
05	28.6900	28.7074	55	349.6213	349.6228
10	30.1619	30.1784	60	367.5469	367.5483
15	31.7091	31.7249	65	386.3915	386.3928
20	33.3357	33.3507	70	406.2023	406.2035
25	35.0456	35.0598	75	427.0287	427.0300
30	36.8431	36.8567	80	448.9231	448.9242
35	38.7328	38.7457	85	471.9399	471.9410
40	40.7193	40.7316	90	496.1369	496.1379
45	42.8076	42.8193	6.95	521.5744	521.5754
50	45.0030	45.0141	7.00	548.3161	548.3170
55	47.3109	47.3215	05	576.4289	576.4298
60	49.7371	49.7472	10	605.9831	605.9839
65	52.2877	52.2973	15	637.0526	637.0534
70	54.9690	54.9781	20	669.7150	669.7157
75	57.7878	57.7965	25	704.0521	704.0528
80	60.7511	60.7593	30	740.1497	740.1504
85	63.8663	63.8741	35	778.0980	778.0986
90	67.1412	67.1486	40	817.9919	817.9925
4.95	70.5839	70.5910	45	859.9313	859.9318
5.00	74.2032	74.2099	50	904.0210	904.0215
05	78.0080	78.0144	55	950.3711	950.3716
10	82.0079	82.0140	60	999.0976	999.0981
15	86.2128	86.2186	65	1050.323	
20	90.6334	90.6389	70	1104.174	
25	95.2805	95.2858	75	1160.780	
30	100.1659	100.1709	80	1220.301	
35	105.3018	105.3065	85	1282.867	
40	110.7009	110.7055	90	1348.641	
45	116.3769	116.3812	7.95	1417.787	
50	122.3439	122.3480	8.00	1490.479	
55	128.6168	128.6207	05	1566.698	
60	135.2114	135.2150	10	1647.234	
65	142.1440	142.1475	15	1731.690	
70	149.4320	149.4354	20	1820.475	
75	157.0938	157.0969	25	1913.813	
80	165.1482	165.1513	30	2011.936	
85	173.6158	173.6186	35	2115.090	
90	182.5173	182.5201	40	2223.533	
95	191.8754	191.8780	45	2337.537	

76. Line Capacity.— To determine the capacity of a transmission line, consider two wires of indefinitely small diameters placed d' centimeters apart and having respectively charges of $+q$ and $-q$

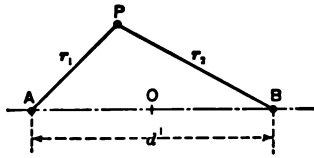

Fig. 97.

units per centimeter length of conductor. The intensity of the electric field at a point P , Fig. 97, distant r_1 cm. from one wire and r_2 cm. from the other,

that is, the electrostatic flux per unit area of equipotential surface or force exerted upon a unit positive charge at this point due to the charge on wire A alone, is

$$F_A = \frac{4\pi q}{2\pi r_1} = 2 \frac{q}{r_1},$$

and that due to the charge on wire B alone is

$$F_B = \frac{-4\pi q}{2\pi r_2} = -2 \frac{q}{r_2}.$$

Representing the potential at the point P due to the charge on A by V_A , and that due to the charge on B by V_B , it follows from the definition of potential that

$$\frac{dV_A}{dr_1} = \frac{2q}{kr_1}$$

and

$$\frac{dV_B}{dr_2} = -\frac{2q}{kr_2}$$

where k is the permittivity or specific inductive capacity of the dielectric. If the potentials at the point O midway between the two very small wires due to their charges be respectively V_A' and V_B' , then the potential difference between P and O is the sum of

$$V_A - V_A' = \int_{r_1}^{\frac{d'}{2}} \frac{2q}{kr_1} dr_1 = \frac{2q}{k} \log_e \frac{d'}{2r_1}$$

and
$$V_B - V_B' = \int_{r_2}^{\infty} -\frac{2q}{kr_2} dr_2 = -\frac{2q}{k} \log_e \frac{\infty}{r_2}.$$

Or, since for the point O , $V_A' + V_B' = 0$, the potential at P due to the charges on both wires is

$$V_A + V_B = V = \frac{2q}{k} \log_e \frac{r_2}{r_1}. \quad (1)$$

For any point to be on the equipotential surface which passes through the point P , the ratio of its distances from B and A respectively must be constant. The locus of a point P which moves so that $\frac{r_2}{r_1}$ is constant is a circle, and if C be its center and r its radius, then

$$CA \times CB = r^2. \quad (2)$$

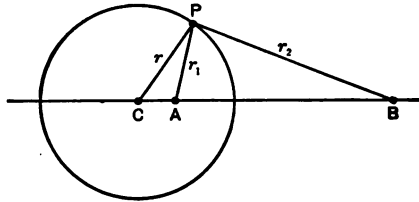

Fig. 98.

From Fig. 98, which is drawn in accordance with equation (2), it appears that triangles ACP and BCP with the common angle at C are similar, since from (2) $\frac{CA}{r} = \frac{r}{CB}$.

Therefore

$$\frac{AP}{CA} = \frac{BP}{CP} \quad \text{or} \quad \frac{r_1}{CA} = \frac{r_2}{r}$$

and
$$\frac{CA}{r} = \frac{r_1}{r_2};$$

which shows that $\frac{r_1}{r_2}$ is constant whatever the position of P on the circle. Consequently the equipotential surfaces resulting from the charges on the two wires A and B are cylindrical in shape and are *not* coaxial with those wires; furthermore, the axes of such cylinders of different radii are not coincident. The radius of the zero potential surface which passes through the mid-point O must be infinitely large (for $\frac{r_1}{r_2} = 1$), and therefore this surface is a neutral plane which bisects the line AB at right angles. All the equipotential surfaces to the left of this plane surround A and those to the right surround B .

Consider two equipotential surfaces surrounding the wires A and B to be replaced by solid cylindrical conductors

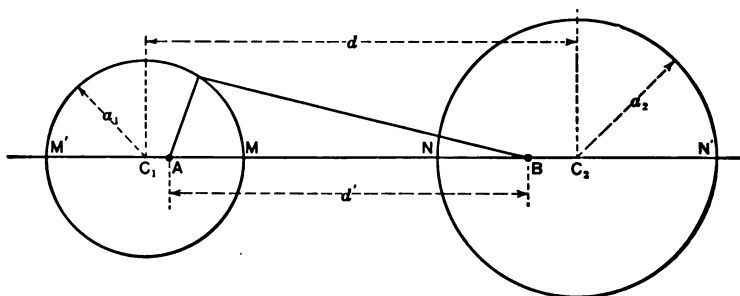

Fig. 99.

of radii a_1 and a_2 respectively, Fig. 99, and carrying charges respectively of $+q$ and $-q$ units per centimeter length of conductor. Such substitution does not alter the potential or electric flux distribution beyond these surfaces. The potentials of the wires are respectively

$$V_1 = \frac{2q}{k} \log_e \frac{BM}{AM}$$

and
$$V_2 = -\frac{2q}{k} \log_e \frac{AN}{BN}.$$

Therefore their potential difference is

$$E = V_1 - V_2 = \frac{2q}{k} \log_e \frac{BM \cdot AN}{AM \cdot BN}.$$

But from the figure

$$\frac{BM}{AM} = \frac{BM'}{AM'} = \frac{BC_1}{a_1};$$

and
$$\frac{AN}{BN} = \frac{AN'}{BN'} = \frac{AC_2}{a_2};$$

also
$$AC_2 \times BC_2 = a_2^2$$

consequently
$$E = \frac{2q}{k} \log_e \frac{BC_1}{BC_2} \cdot \frac{a_2}{a_1}. \quad (3)$$

Furthermore,

$$BC_1 (BC_1 - d') = a_1^2$$

and
$$BC_2 (BC_2 + d') = a_2^2;$$

whence
$$BC_1 = \frac{d'}{2} + \sqrt{a_1^2 + \frac{d'^2}{4}}$$

and
$$BC_2 = -\frac{d'}{2} + \sqrt{a_2^2 + \frac{d'^2}{4}}.$$

Therefore the capacity per centimeter length of line having two cylinders of radii a_1 and a_2 as conductors is, from (3),

$$\frac{k}{2 \left[\log_e \left(\frac{d'}{2a_1} + \sqrt{1 + \left(\frac{d'}{2a_1} \right)^2} \right) - \log_e \left(-\frac{d'}{2a_2} + \sqrt{1 + \left(\frac{d'}{2a_2} \right)^2} \right) \right]}.$$

If both wires have the same diameter, $r = a_1 = a_2$, and the capacity is

$$C = \frac{k}{2 \log_e \left[\frac{\sqrt{1 + \left(\frac{d'}{2r}\right)^2} + \frac{d'}{2r}}{\sqrt{1 + \left(\frac{d'}{2r}\right)^2} - \frac{d'}{2r}} \right]} \quad (4)$$

Representing the distance between conductor axes by d , it is seen that

$$d = BC_1 + BC_2 = 2 \sqrt{r^2 + \left(\frac{d'}{2}\right)^2},$$

whence

$$d' = \sqrt{d^2 - 4r^2}.$$

Therefore the capacity of a transmission line having conductors of r centimeters radius is

$$C = \frac{k}{2 \log_e \left[\frac{d + \sqrt{d^2 - 4r^2}}{d - \sqrt{d^2 - 4r^2}} \right]}$$

or, letting $\frac{d}{2r} = m$, this becomes

$$C = \frac{k}{2 \log_e \left[\frac{m + \sqrt{m^2 - 1}}{m - \sqrt{m^2 - 1}} \right]} = \frac{k}{4 \log_e (m + \sqrt{m^2 - 1})}.$$

This may also be expressed as

$$C = \frac{k}{4 \cosh^{-1} m} \text{ electrostatic units.}$$

Reducing to microfarads per mile, the capacity of either wire with respect to the neutral plane is

$$C = \frac{0.0388 k}{\log_{10} \left[\frac{d}{2r} + \sqrt{\frac{d^2}{4r^2} - 1} \right]}, \quad (5)$$

or

$$C = \frac{0.0895 k}{\cosh^{-1} \frac{d}{2r}}. \quad (6)$$

By neglecting the unity term under the radical of equation (5), it assumes the approximate and widely known form:

$$C = \frac{0.0388 k}{\log_{10} \frac{d}{r}}. \quad (7)$$

In applying these equations and that for inductance (§ 74) to 3-phase circuits where the conductors are not equidistant, the effective spacing d is to be taken as the cube root of the product of the three conductor spacings.

77. Equations of Wave Propagation along Wires. — Any polyphase transmission line can be resolved into separate single-phase single-wire circuits with imaginary perfectly conducting ground return paths. Thus, the voltage on a representative single-wire circuit of a three-phase transmission line with E volts between wires is $\frac{E}{\sqrt{3}}$, which is the

voltage from one conductor to neutral. Such a line transmits one-third of the total power. It is therefore only necessary to consider the current and voltage distribution on a single-wire circuit.

Consider the element ds of a uniform line with a perfectly conducting ground return circuit, at a distance s from the end upon which an alternating electromotive force is impressed, as shown in Fig. 100. A current will flow through the conductor, which at a given instant t at the element ds may be represented by I' , and that in the adjacent elements by $I' + dI'$ and $I' - dI'$, the latter referring to the next adjacent element more remote from the generator. Let E' be the potential at this instant of the

line with respect to the earth at the element ds , and let the potentials of the adjoining elements be $E' + dE'$ and $E' - dE'$ respectively. Let R , L , and C in homologous

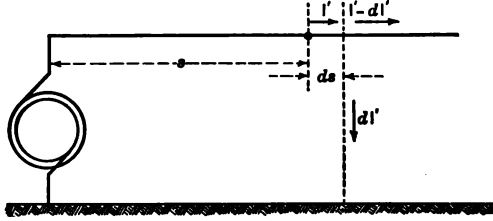

Fig. 100.

units represent respectively the uniformly distributed resistance, inductance, and capacity per unit length of the line.

The difference of potential between the two ends of the element ds is dE' , and this must be equal to the sum of the resistance and inductance reactions of the elementary line section occasioned by the current I' ; consequently for this element

$$Lds \frac{dI'}{dt} + RdsI' = -dE'$$

or

$$L \frac{dI'}{dt} + RI' = -\frac{dE'}{ds} \quad (1)$$

Since the line has capacity with respect to the earth, it takes a charging current; and in addition a slight leakage current may flow. Therefore the current which does not continue beyond the element ds , but which flows from the line to ground under the voltage E' , is

$$-dI' = \frac{d}{dt}(E'Cds) + E'gds,$$

where g is the leakance or the reciprocal of the insulation resistance per unit length of line. Then

$$-\frac{dI'}{ds} = C \frac{dE'}{dt} + E'g. \quad (2)$$

Differentiating (1) with respect to time and (2) with respect to distance, there result respectively

$$L \frac{d^2 I'}{dt^2} + R \frac{dI'}{dt} = -\frac{d}{dt} \left(\frac{dE'}{ds} \right) = -\frac{d}{ds} \left(\frac{dE'}{dt} \right)$$

$$\text{and} \quad -\frac{d^2 I'}{ds^2} = C \frac{d}{ds} \left(\frac{dE'}{dt} \right) + g \frac{dE'}{ds}.$$

Substitution of the former in the latter equation gives

$$\frac{d^2 I'}{ds^2} = CL \frac{d^2 I'}{dt^2} + RC \frac{dI'}{dt} - g \frac{dE'}{ds},$$

and replacing the last term by its equivalent from (1) there is obtained the differential equation of current propagation along a line as

$$CL \frac{d^2 I'}{dt^2} + (RC + gL) \frac{dI'}{dt} = \frac{d^2 I'}{ds^2} - RgI'. \quad (3)$$

Similarly, by differentiating (1) with respect to distance and (2) with respect to time, and combining the resulting expressions, there results the differential equation of voltage propagation as

$$CL \frac{d^2 E'}{dt^2} + (RC + gL) \frac{dE'}{dt} = \frac{d^2 E'}{ds^2} - RgE'. \quad (4)$$

Equations (3) and (4) are identical as to I' and E' , and their solution indicates the current and voltage values at the point distant s from the generator at the time t in terms of the line constants. This general equation refers to any circuit with distributed capacity and inductance,

and its solution is of importance in telephonic and power transmission problems.

78. Attenuation and Wave-Length Coefficients. — The solution of the equation of wave propagation may readily be effected by not considering the short unsteady period immediately following the application of voltage to the line, for then the solution may be simplified by the introduction of the complex quantity which results in the elimination of the time variable. The resulting expressions are complex quantities and their interpretation must be made accordingly.

Introducing the quadrantal operator, $j = \sqrt{-1}$, and counting the distance s positive from the receiving end of the line, equations (1) and (2) of § 77 for the steady state may be written*

$$\frac{dE_m}{ds} = (R + j\omega L) I_m \quad (1)$$

and
$$\frac{dI_m}{ds} = (g + j\omega C) E_m, \quad (2)$$

where E_m and I_m represent the maximum (or effective) values of electromotive force and current at any point on the circuit, $(R + j\omega L)$ is the conductor impedance, and $(g + j\omega C)$ is the dielectric admittance. Differentiating either of these expressions and substituting the other in the result yields respectively

$$\frac{d^2 E_m}{ds^2} = (R + j\omega L) (g + j\omega C) E_m = \gamma^2 E_m \quad (3)$$

and
$$\frac{d^2 I_m}{ds^2} = (R + j\omega L) (g + j\omega C) I_m = \gamma^2 I_m, \quad (4)$$

* See p. 74, *Alternating Current Machines* (1908) by Sheldon, Mason, and Hausmann.

where $\gamma^2 = (R + j\omega L)(g + j\omega C)$ for convenience. Equations (3) and (4) are identical equations as to E_m and I_m and differ only in the terminal conditions, consequently the solution of one will suffice.

Considering equation (4) and multiplying through by $2 \frac{dI_m}{ds}$, there results

$$2 \frac{dI_m}{ds} \cdot \frac{d^2 I_m}{ds^2} = 2 \gamma^2 I_m \frac{dI_m}{ds},$$

which when integrated becomes

$$\left(\frac{dI_m}{ds}\right)^2 = \gamma^2 I_m^2 + c_1.$$

Replacing the constant of integration c_1 by $\gamma^2 c_2^2$, where c_2 is also a constant, and separating the variables, there results

$$\frac{dI_m}{\sqrt{I_m^2 + c_2^2}} = \gamma ds.$$

Integration yields

$$\log_e [c_3 (I_m + \sqrt{I_m^2 + c_2^2})] = \gamma s,$$

where c_3 is another constant of integration. Writing in exponential form, this equation becomes

$$\epsilon^{\gamma s} = (I_m + \sqrt{I_m^2 + c_2^2}) c_3.$$

Squaring, $I_m^2 + c_2^2 = \frac{\epsilon^{2\gamma s}}{c_3^2} + I_m^2 - 2 I_m \frac{\epsilon^{\gamma s}}{c_3}$,

or $\frac{\epsilon^{2\gamma s}}{c_3^2} - c_2^2 = 2 I_m \frac{\epsilon^{\gamma s}}{c_3}$;

whence

$$I_m = \frac{\epsilon^{\gamma s}}{2 c_3} - \frac{c_2^2 c_3 \epsilon^{-\gamma s}}{2} = A \epsilon^{\gamma s} - B \epsilon^{-\gamma s}, \quad (5)$$

where the two constants are $A = \frac{1}{2 c_3}$ and $B = \frac{c_2^2 c_3}{2}$.

Since the exponential coefficient γ is the square root of

the product of two complex numbers, it also is a complex quantity, and may be written

$$\gamma = \beta + j\alpha, \quad (6)$$

where β and α are its two rectangular components. Then

$$\beta^2 + 2j\alpha\beta + j^2\alpha^2 = (R + j\omega L)(g + j\omega C),$$

$$\text{or } (\beta^2 - \alpha^2) + 2j\alpha\beta = (Rg - \omega^2 CL) + j(g\omega L + \omega RC).$$

This equation can be true only if

$$\alpha^2 - \beta^2 = \omega^2 CL - Rg,$$

and if

$$2\alpha\beta = \omega(RC + gL).$$

These are simultaneous equations which can be solved for α and β . Thus, substituting the value of α from the latter in the former gives the biquadratic

$$\beta^4 + (\omega^2 LC - Rg)\beta^2 - \frac{\omega^2}{4}(RC + gL)^2 = 0;$$

whence

$$\beta^2 = -\frac{\omega^2 LC - Rg}{2} \pm \frac{1}{2}\sqrt{(\omega^2 LC - Rg)^2 + \omega^2(RC + gL)^2}$$

and

$$\beta = \sqrt{\frac{1}{2}[\sqrt{(\omega^2 C^2 + g^2)(R^2 + \omega^2 L^2)} - \omega^2 LC + Rg]}; \quad (7)$$

similarly

$$\alpha = \sqrt{\frac{1}{2}[\sqrt{(\omega^2 C^2 + g^2)(R^2 + \omega^2 L^2)} + \omega^2 LC - Rg]}. \quad (8)$$

The constant β is called the *attenuation coefficient*, and α is called the *wave-length constant*. These constants give the value of γ in equation (5) for the current at any point of the line.

79. Current and Voltage Distribution on Lines. — Applying hyperbolic functions to equation (5) of the foregoing paragraph for the current on a line at a point distant s from the receiving end, there results

$$\begin{aligned} I_m &= A (\cosh \gamma s + \sinh \gamma s) - B (\cosh \gamma s - \sinh \gamma s). \\ &= (A - B) \cosh \gamma s + (A + B) \sinh \gamma s. \end{aligned} \quad (1)$$

The voltage at the same point is found by differentiating (1) with respect to distance and substituting $\frac{dI_m}{ds}$ in equation (2) of § 78. Since

$$\frac{d}{ds} \cosh \gamma s = \gamma \sinh \gamma s \quad \text{and} \quad \frac{d}{ds} \sinh \gamma s = \gamma \cosh \gamma s,$$

there results

$$E_m = \frac{\beta + j\alpha}{g + j\omega C} [(A - B) \sinh \gamma s + (A + B) \cosh \gamma s]. \quad (2)$$

The constants A and B of equations (1) and (2) may be determined from the conditions at the receiving end of the line. Let E_r and I_r be the maximum (or effective) values of the voltage and current at this terminal. Then for $s = 0$, since $\cosh(0) = 1$, and $\sinh(0) = 0$,

$$I_r = A - B$$

and
$$E_r = \frac{\beta + j\alpha}{g + j\omega C} (A + B).$$

Substituting these values in (1) and (2) and remembering that the complex quantity

$$\gamma^2 = (\beta + j\alpha)^2 = (R + j\omega L)(g + j\omega C),$$

there results:

$$I_m = I_r \cosh \gamma s + E_r \frac{\beta + j\alpha}{R + j\omega L} \sinh \gamma s \quad (3)$$

and
$$E_m = E_r \cosh \gamma s + I_r \frac{\beta + j\alpha}{g + j\omega C} \sinh \gamma s. \quad (4)$$

When s is reckoned from the generator toward the receiving end of the line, these equations become

$$I_m = I_0 \cosh \gamma s - E_0 \frac{\beta + j\alpha}{R + j\omega L} \sinh \gamma s \quad (5)$$

$$\text{and} \quad E_m = E_g \cosh \gamma s - I_g \frac{\beta + j\alpha}{g + j\omega C} \sinh \gamma s. \quad (6)$$

The hyperbolic functions of the quantity γ may be expanded by using $\cosh j\mu = \cos \mu$ and $\sinh j\mu = j \sin \mu$; thus

$$\cosh \gamma s = \cosh (\beta s + j\alpha s) = \cosh \beta s \cdot \cos \alpha s + j \sinh \beta s \cdot \sin \alpha s$$

and

$$\sinh \gamma s = \sinh \beta s \cdot \cos \alpha s + j \cosh \beta s \cdot \sin \alpha s.$$

The terminal conditions in any special problem are usually specified, the voltage being considered the reference phase. In the present notation for vector rotation a current leading the voltage is written $i_1 + ji_2$ and a lagging current is represented by $i_1 - ji_2$.

From equation (5) it is seen that for an infinitely long line, $s = \infty$, on which the current at the inaccessible end is zero, $I_m = 0$,

$$I_g = E_g \frac{\beta + j\alpha}{R + j\omega L},$$

which, when substituted in the same equation, gives the current, at a point distant s from the generator end of such a line, as

$$I_m = I_g (\cosh \gamma s - \sinh \gamma s) = I_g e^{-\gamma s}.$$

$$\text{Similarly} \quad E_m = E_g e^{-\gamma s} = E_g e^{-\beta s} e^{-j\alpha s}.$$

The exponential function with the imaginary exponent may be written in the trigonometric form by means of the expression

$$e^{\pm j\alpha s} = \cos \alpha s \pm j \sin \alpha s,$$

$$\text{whence} \quad \frac{I_m}{I_g} = \frac{E_m}{E_g} = e^{-\beta s} (\cos \alpha s - j \sin \alpha s), \quad (7)$$

wherein α is the delay in phase in radians per unit length of line (mile). If a length of line r miles be chosen so as to

contain exactly n wave-lengths, then $2\pi n = \alpha r$, and the wave length is

$$\lambda = \frac{r}{n} = \frac{2\pi}{\alpha} \text{ miles.}$$

As the frequency f of the impressed electromotive force is $\frac{\omega}{2\pi}$ cycles per second, the velocity of wave propagation will be

$$v = f\lambda = \frac{\omega}{2\pi} \cdot \frac{2\pi}{\alpha} = \frac{\omega}{\alpha} \text{ miles per sec.}$$

The expression for α in terms of the line constants is given in § 78. For a perfectly insulated resistanceless line $g = 0$, $R = 0$, $\alpha = \omega\sqrt{LC}$, and the velocity of wave propagation $v = \frac{1}{\sqrt{LC}}$, is that of light, namely 3×10^{10} centimeters per second, or 186,000 miles per second.

80. Regulation. — The voltage regulation of a transmission line is the ratio of the voltage variation at the receiving end between no load and full non-inductive load to the full-load voltage at the same end of the line for constant impressed voltage at the other end.

When the transmission line is open-circuited at the receiving end, the current, I_{g_0} , entering it at the generator, called the charging current, is obtained from equation (5) of the preceding article for $s = S =$ total length of the line, by placing $I_m = 0$.

$$\text{Then} \quad I_{g_0} = E_g \frac{\beta + j\alpha}{R + j\omega L} \cdot \frac{\sinh \gamma S}{\cosh \gamma S}.$$

$$\text{Since} \quad \frac{\sinh \gamma S}{\cosh \gamma S} = \tanh \gamma S,$$

$$\text{this becomes} \quad I_{g_0} = E_g \frac{\beta + j\alpha}{R + j\omega L} \tanh \gamma S. \quad (1)$$

Substituting this value for I_0 in equation (6) of § 79, there results the voltage at any point distant s from the generating end of the line as

$$E_s = E_0 (\cosh \gamma s - \sinh \gamma s \cdot \tanh \gamma S), \quad (2)$$

and the voltage at the receiving end for $s = S$ as

$$E_{r_0} = E_0 (\cosh \gamma S - \sinh \gamma S \cdot \tanh \gamma S),$$

or, since $\cosh^2 \gamma S - \sinh^2 \gamma S = 1$,

$$E_{r_0} = \frac{E_0}{\cosh \gamma S} = E_0 \operatorname{sech} \gamma S. \quad (3)$$

The regulation of the transmission line is then expressed as

$$\text{Regulation} = \frac{E_{r_0} - E_r}{E_r} = \frac{E_0 \operatorname{sech} \gamma S - E_r}{E_r}. \quad (4)$$

81. Numerical Illustration. — Let it be required to transmit 10,000 kilowatts at 60 cycles over a three-phase aerial transmission line 300 miles long, employing stranded aluminum conductors 0.63 inch in diameter of area 0.236 square inch, triangularly spaced with 9 feet interaxial distance. The voltage at the receiving end of the line is to be 100,000 volts between conductors, and the power factor of the load is 85 per cent lagging. Determine the voltage to be impressed on the line, the entering current, the efficiency of transmission, the voltage regulation of the line, and the charging current.

The constants per mile of a representative single circuit with a perfectly conducting ground return path and carrying one-third of the total energy, are

$$\begin{aligned} R &= 0.30 \text{ ohm,} \\ L &= 0.00196 \text{ henry,} \\ C &= 0.0153 \times 10^{-6} \text{ farad,} \\ g &= \text{practically zero.} \end{aligned}$$

The current per single circuit (or per wire) at the load end is

$$I_r = \frac{10,000,000}{3 \times \frac{100,000}{\sqrt{3}} \times 0.85} = 68.0 \text{ amperes,}$$

or $I_r = 68.0 [0.85 - j \sin (\cos^{-1} 0.85)] = 57.8 - 35.8j$;

the voltage at the receiving end, namely $\frac{100,000}{\sqrt{3}}$ or 57,700 volts per phase, being considered the datum phase.

The attenuation and wave-length constants per mile for a frequency of 60 cycles (whence $\omega = 377$) are respectively

$$\beta = \sqrt{2.88 (\sqrt{0.090 + 0.5476} - 0.74)} \times 10^{-3} = 0.000412$$

and $\alpha = \sqrt{2.88 (0.799 + 0.740)} \times 10^{-3} = 0.00210$.

The hyperbolic and circular functions respectively of βs and αs for the total length of the transmission line are

$$\begin{aligned} \cosh (0.1236) &= 1.00765 & \cos (0.630) &= \cos 36^\circ 6' = 0.8080 \\ \sinh (0.1236) &= 0.1239 & \sin (0.630) &= 0.5892. \end{aligned}$$

The current at the generator end of the line may then be obtained from equation (3) of § 79 as

$$\begin{aligned} I_g &= (57.8 - 35.8j)(1.00765 \times 0.8080 + 0.1239 \times 0.5892j) \\ &+ 57.7 \left(\frac{0.412 + 2.1j}{0.30 + 0.74j} \right) (0.1239 \times 0.8080 + 1.00765 \times 0.5892j), \end{aligned}$$

or

$$\begin{aligned} I_g &= (57.8 - 35.8j) (0.8142 + 0.0730j) \\ &+ 90.5 (1.678 + 0.325j) (0.1001 + 0.5937j) \\ &= 49.67 - 24.93j + 90.5 (-0.0249 + 1.027j) \\ &= 47.42 + 68.01j \text{ amperes,} \end{aligned}$$

and the current from the generator per wire is 82.9 amperes.

Similarly the voltage at the generator end of the transmission line is

$$\begin{aligned}
 E_g &= (57.8 - 35.8j) \frac{0.412 + 2.1j}{5.76j \cdot 10^{-3}} (0.1001 + 0.5937j) \\
 &\quad + 57,700 (0.8142 + 0.0730j) \\
 &= (57.8 - 35.8j) (0.364 - 0.0715j) (0.1001 + 0.5937j) 10^3 \\
 &\quad + (46.95 + 4.21j) 10^3 \\
 &= (12.04 + 9.23j + 46.95 + 4.21j) 10^3 \\
 &= 58,990 + 13,440j,
 \end{aligned}$$

and the voltage per single circuit to be impressed on the line in order to have 57,700 volts per phase at the receiving end is 60,490 volts.

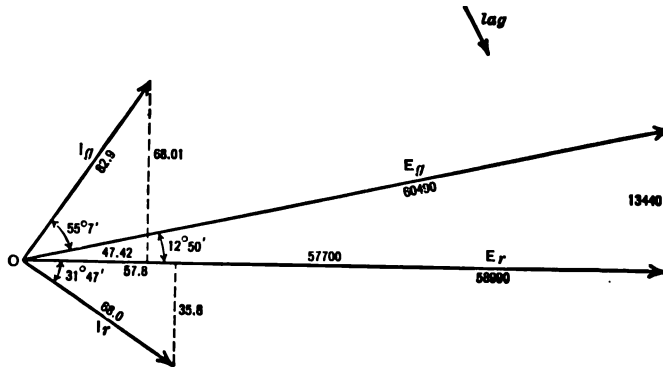

Fig. 101.

The vector diagram, Fig. 101, exhibits the phase relations of the voltages and currents at the ends of the line. It is seen herefrom that the current at the generator end leads the voltage at the same place by the angle $55^\circ 7' - 12^\circ 50'$, or $42^\circ 17'$.

The efficiency of transmission at full load is

$$\frac{57,700 \times 57.8}{60,490 \times 82.9 \cos (42^\circ 17')} = 0.899, \text{ or } 89.9 \text{ per cent.}$$

Since $\cosh \gamma S = 0.8142 + 0.0730j$, the voltage at the receiving end on open circuit for the same impressed *E.M.F.* at the generator end is

$$E_{r0} = \frac{58,990 + 13,440j}{0.8142 + 0.0730j} = 73,350 + 9,930j,$$

and the absolute value is 74,900 volts. Consequently the voltage regulation of the transmission line for 85 per cent power factor is

$$\frac{73,900 - 57,700}{57,700} = 0.281, \text{ or } 28.1 \text{ per cent.}$$

The charging current per single circuit or per wire is obtained from equation (1) of § 80 as

$$\begin{aligned} I_{c0} &= (58,990 + 13,440j) \left(\frac{0.412 + 2.1j}{0.30 + 0.74j} \right) \left(\frac{0.1001 + 0.5937j}{0.8142 + 0.0730j} \right) \\ &= (138.5 + 31.5j) (1.678 + 0.325j) (0.1248 + 0.476j) \\ &= -18.8 + 118.0j, \end{aligned}$$

and the absolute value is 119.5 amperes, and leads the voltage E_r by $99^\circ 3'$. Therefore the charging current at the generating end of the line leads the voltage at the same place by the angle $99^\circ 3' - 12^\circ 50'$, or by $86^\circ 13'$.

82. Corona Loss. — It is found by experiment that the corona loss on a transmission line is proportional to the square of the excess voltage over the critical disruptive value, and is dependent upon the frequency, the size of the conductors, the distance between them, and the density of the air. The loss per mile in watts on a single conductor under fair weather conditions is given by Peek as

$$P = 3.9 \frac{f + 25}{\delta} \sqrt{\frac{D}{2d}} (E_m - E_{cr})^2, \quad (1)$$

where E_m is the voltage (effective value in kilovolts) from conductor to neutral, E_{cr} is the effective value of the critical disruptive voltage in kilovolts to neutral (§ 72), f is the frequency in cycles per second, δ is the air density factor (§ 72), D is the conductor diameter in inches, and d is the distance between centers of conductors in inches.

This expression shows that the corona loss increases very rapidly as the voltage is raised beyond the critical voltage E_{cr} . It is not desirable nor economical to operate transmission lines above the disruptive critical voltage because of the production of noise and luminous discharge and of chemical action at the conductor surface. The corona loss is increased by smoke, fog, rain, sleet and snow; in order to approximate the loss during storms consider E_{cr} as 80 per cent of its fair-weather value as given by equation (1).

The method of measuring corona loss is by means of a wattmeter, the current coil of which is connected directly in the transmission line at the neutral, which is grounded, and the potential coil of the wattmeter is connected to the high-potential transformer coil.

An important consideration arises when the distant end of a long transmission line is open-circuited, for the voltage at every point on the line increases, and the potential over a considerable portion of the circuit exceeds the critical voltage, and consequently a loss of energy ensues. This loss begins at that point where the voltage E_0 is just equal to the critical value E_{cr} , and becomes greater and greater as the far end is approached. The voltage at any point on an open-circuited line is given by equation (2) of § 80. By substituting various values of s therein, and plotting the corresponding values of E_0 in terms of distance, a voltage-distribution curve for the particular line will result.

From this voltage-distance curve can be seen the distance, s_0 , from the generator end of the transmission line at which corona loss begins. Of course, this equation might be solved for s_0 , but not knowing the phase of voltage E_0 at the end of this part of the circuit, this plan leads to difficulty in the solution of actual problems.

In order to determine the total corona loss on an open-circuited single conductor of length S , consider an element ds of the circuit, distant s miles from the point s_0 where corona loss begins, for which the excess voltage is $E_m - E_{cr}$ kilovolts; Fig. 102. The

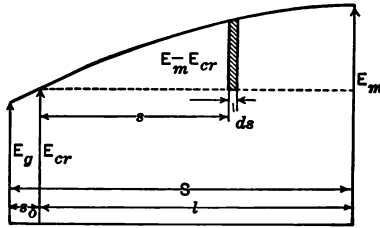

Fig. 102.

power loss over this elementary line section in watts is

$$dP = K (E_m - E_{cr})^2 ds,$$

where K replaces the terms of equation (1) not included in the parenthesis; and over the entire distance $l = S - s_0$ the loss is

$$P = K \int_0^l (E_m - E_{cr})^2 ds.$$

Applying equation (2) of § 80,

$$E_m = E_{cr} (\cosh \gamma s - \sinh \gamma s \tanh \gamma l);$$

therefore

$$\begin{aligned} P &= KE_{cr}^2 \int_0^l (\cosh \gamma s - \sinh \gamma s \tanh \gamma l - 1)^2 ds, \\ &= KE_{cr}^2 \left[\int_0^l \cosh^2 \gamma s ds - 2 \tanh \gamma l \int_0^l \sinh \gamma s \cosh \gamma s ds \right. \\ &\quad \left. - 2 \int_0^l \cosh \gamma s ds + \tanh^2 \gamma l \int_0^l \sinh^2 \gamma s ds \right] \end{aligned}$$

$$+ 2 \tanh \gamma l \int_0^l \sinh \gamma s \, ds + \int_0^l ds \Big].$$

Upon integration this equation becomes

$$P = \frac{K}{2\gamma} E_{cr}^2 [\sinh \gamma l \cosh \gamma l + \gamma l - \tanh \gamma l (\cosh 2\gamma l - 1) \\ - 4 \sinh \gamma l + \tanh^2 \gamma l (\sinh \gamma l \cosh \gamma l - \gamma l) \\ + 4 \tanh \gamma l (\cosh \gamma l - 1) + 2\gamma l],$$

and when simplified reduces to

$$P = \frac{K}{2} E_{cr}^2 l \left[3 - \frac{3 \tanh \gamma l}{\gamma l} - \tanh^2 \gamma l \right] \quad (2)$$

as the expression for the total corona loss in watts on an open-circuited single conductor.

As an illustration consider a 60-cycle, three-phase transmission line with No. 0000 stranded aluminum conductors (0.53 inch diameter) placed triangularly 15 feet apart. The line constants per mile on a representative single-wire circuit which transmits one-third of the total energy, are $R = 0.463$ ohm (includes resistance increase due to skin effect and stranding), $L = 0.00218$ henry, $C = 0.0137$ microfarad, and g is negligibly small = 0.

The disruptive critical voltage of this line is given by equation (7) of § 72 as

$$E_{cr} = 21.9 \times 0.85 \times \frac{0.53 \times 2.54}{2} \log_e \frac{2 \times 15 \times 12}{0.53} = 82$$

kilovolts to neutral for $\delta = 1$ (see also Fig. 93).

The attenuation and wave-lengths constants per mile are respectively

$$\beta = 0.000563$$

and

$$\alpha = 0.00214;$$

whence

$$\gamma = 0.000563 + 0.00214j.$$

If a length of 100 miles ($l = 100$) at the open-circuited end of the line has a voltage greater than E_{cr} , then

$$\gamma l = 0.0563 + 0.2140j,$$

$$\sinh \gamma l = 0.0550 + 0.2123j,$$

$$\cosh \gamma l = 0.9788 + 0.0120j,$$

$$\tanh \gamma l = 0.0589 + 0.2161j,$$

$$\frac{3 \tan \gamma l}{\gamma l} = 3.0308 - 0.0264j,$$

$$\tanh^2 \gamma l = -0.0432 + 0.0255j,$$

$$K = 3.9 \frac{60 + 25}{1} \sqrt{\frac{0.53}{2 \times 15 \times 12}} = 12.7,$$

and

$$P = \frac{12.7}{2} (82)^2 100 [3 - (3.0308 - 0.0264j) - (-0.0432 + 0.0255j)]$$

= 53,000 watts, or 53 kilowatts.

Whence the corona loss on the three wires would be

$$3 \times 53 = 159 \text{ kilowatts.}$$

83. Lightning. — The physical processes, accompanying the establishment of atmospheric differences of potential, resultant discharges from which are known as *lightning*, are not well understood. Closely related to the phenomenon are two facts established by somewhat recent experiments.

As the result of the presence in the earth of radioactive substances and the characteristics of their decay, the lower strata of the atmosphere are partially ionized. The number of positive ions per unit volume usually exceeds the number of negative ions. This excess seems to disappear at an elevation of about 10 miles. The resultant positive volume electrification establishes a positive potential

in the various strata with respect to the surface of the earth. Fig. 103, due to Liebenon, shows the calculated potential differences for strata of various altitudes, and is based upon experimental evidence.

Air saturated with water vapor requires the presence of

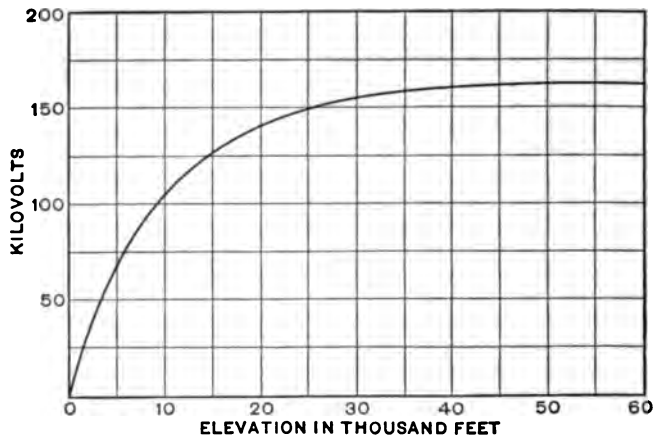

Fig. 103.

solid nuclei in order that the vapor may condense to form the globules which constitute a cloud. Frequently these nuclei consist of dust particles. Kelvin showed that the necessity of a nucleus was due to the influence of curvature of surface upon the vapor tension, because the greater the curvature of a liquid surface the more it tends to evaporate. J. J. Thomson showed that electrification would partially neutralize the effect of curvature; and C. T. R. Wilson showed that ionized air required less supersaturation to effect cloud formation than non-ionized air and that negative ions were more effective than positive ions. Since uncharged globules of a cloud continually move under the

influence of the excess of gravitational force above the force of air resistance, and since charged globules move as the result of an additional force due to the presence of the electric field, — positive or negative according to the sign of the charge, — it is reasonable to believe that these forces contribute towards the establishment of potential differences between different parts of a cloud, between clouds, and between a cloud and the earth. Under potential differences of sufficient magnitude the intervening air breaks down accompanied by a discharge.

The gradual formation of a cloud over a transmission line electrostatically induces a charge in the line wires and holds it bound. Upon the neutralization of the cloud potential by discharge, the energy of the charge on the lines is delivered to the line, and tends to dissipate itself under conditions prescribed by the constants of the line and its environment. Current *surges* may be set up in the line circuit and be superposed upon the normal currents, which surges will cease when the energy has been expended in heating the conductors, or an arc may be initiated between a wire and ground over an insulator or between two wires. The subsequent maintenance of the arc will be due to energy supplied by the generator. The current in an arc to ground is generally intermittent and, if maintained, may set up *resonant currents* in apparatus connected with the line, since each piece of apparatus has a natural frequency of its own. These resonant currents are likely to be accompanied by voltages of magnitude sufficient to destroy insulation and cause short circuits.

The energy of the magnetic field associated with a short circuit between line wires is delivered to the line when the short circuit ceases, and may cause surges similar to those

which result from lightning. Some writers have therefore extended the meaning of the term "lightning" to include such phenomena.

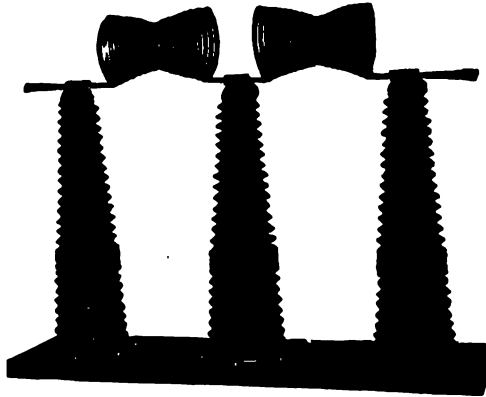

Fig. 104.

84. Protection from Lightning. — In order to protect apparatus from the high voltages due to lightning it is common to insert *choke coils*, Fig. 104, in series between the apparatus terminals and the line wires so that the incoming high-voltage wave front may be retarded thereby for a short interval of time. On the line side of the choke coil is installed a grounded device which conductively connects the line with the ground whenever the voltage of the line exceeds a predetermined value. This device is termed a *lightning arrester*, and its operation, in connection with the choke coil, quickly relieves the line of excessive potentials. Some means must be employed, however, to prevent the maintenance of a discharge at normal voltage from the line to ground over the path rendered conductive by the initial discharge under excessive potentials. In nearly all types of arresters the circuit from the line wire to the ground is

normally interrupted by a short dielectric gap which will break down under a slight excess over normal voltage. The various arresters differ from each other in the means employed to suppress the subsequent flow of current at normal voltage. In one type this is accomplished by separating the spark-gap electrodes by means of a plunger

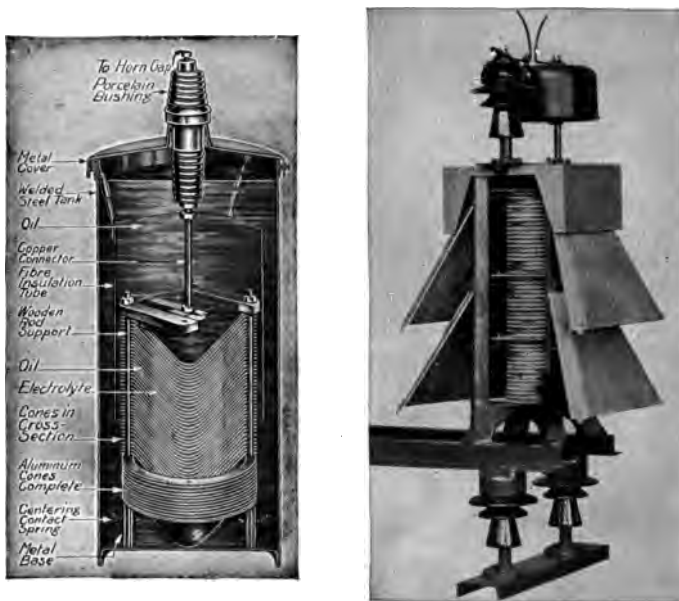

Fig. 105.

solenoid; in another there is an electromagnetic blow-out; and in another, for use on alternating circuits, there is a series of gaps between electrodes which will not permit the maintenance of an arc at normal potentials.

Two types of lightning arresters have proved particularly effective in the protection of station apparatus, namely the aluminum-cell and the oxide-film arresters. The former

consists of a series of aluminum cup-shaped electrodes upon whose surfaces are formed films of aluminum hydroxide, immersed at short distances from each other in a suitable electrolyte. The cross section of such an arrester is shown at the left in Fig. 105. It is characterized by the conduction of minute currents at normal voltage and of very large currents, without much elevation of temperature, at voltages slightly in excess of normal. The number of electrodes or cells depends on the operating voltage, each cell withstanding permanently about 300 volts. To avoid loss of energy under normal potentials these arresters are connected in series with a horn gap. This practice necessitates daily charging of the arrester, as the film dissolves rapidly.

The oxide-film lightning arrester consists of a series of circular sherardized iron electrodes separated by porcelain rings, the space between the electrodes being filled with lead peroxide, a good conductor, applied under moderate pressure. When a current is passed through the arrester heat is developed at the contacts of the peroxide and metal because of the contact resistance, and when the temperature reaches about 150 deg. cent. the peroxide at the metal surfaces is reduced to a lower oxide, red lead, an insulator; consequently obstructing the current flow. The number of peroxide layers or cells in the arrester depends upon the operating voltage, allowing about 250–400 volts per cell. When subjected to an over voltage the insulating films are punctured and the discharge takes place through the lead peroxide, but the dynamic current following this discharge converts the surfaces of the peroxide into the lower non-conducting oxide, and thus seals the punctures in the films. Commercially, the films are put on initially by dipping the plates in a suitable insulating varnish, and after assembly

the passage of a current seals any openings that may exist in the varnish film. The arrester is used with a spark gap in series, and is depicted at the right of Fig. 105, the metal housing being shown removed at one side. The fact that this arrester need not be charged extends its use to localities where there are no attendants.

No effective means has been found for the protection of a transmission line from a direct stroke of lightning. Such strokes usually result in short circuits and shattered insulators. The damage is usually confined to one tower on metal tower lines, but extends over several poles when the cross arms and poles are of wood.

When the stroke is not direct but in the vicinity of the line, a common result is a *spill-over* or arc to ground over

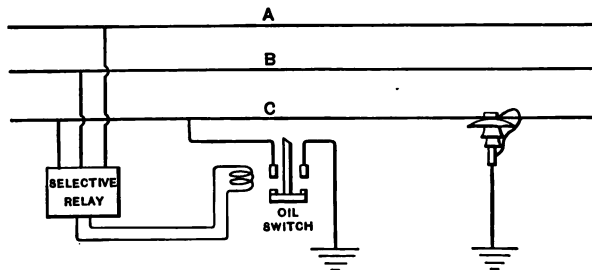

Fig. 106.

an insulator. The maintenance of the arc after the stroke by energy from the generator is likely to destroy the insulator, to set up surges, and to interrupt the service. To interrupt such arcs, E. E. F. Creighton has devised a *suppressor*, which automatically grounds the affected line at the station for a short interval of time, sufficient to allow the conducting vapors to escape and the insulator to cool off. This time is not so great as to interrupt the service because of the slowing down of synchronous apparatus.

The arc ceases because the ground at the station robs it of its potential. Fig. 106 is a diagram of the circuit connections. The selective relay, which controls the operation of the grounding oil switch, is itself controlled by electrostatic forces on high-voltage lines and by electromagnetic forces on moderate-voltage lines. The relay contact is normally held open by these balanced forces, but is closed when the balance is destroyed.

Success has been attained in protecting lines by *ground wires* erected above the line and connected with ground at every fifth pole or so. The use of such wires has resulted in a reduction of 50 per cent in insulator failures.

PROBLEMS.

42. Plot a curve showing the resonant frequency of open-circuited transmission lines of various lengths when connected to impedanceless generating units. What length of line corresponds in periodicity with the fifth harmonic of a wave whose fundamental frequency is 25 cycles?

43. Determine the economic voltage to be employed in transmitting 15,000 kilowatts at 25 cycles to a single substation over a 120-mile three-phase aerial transmission line using aluminum conductors. Take the equivalent annual hours of operation as 4000, the mean annual power factor as 0.85, the cost of line material as 0.24 dollars per pound, and all other factors as suggested in § 71.

44. Calculate the critical disruptive voltage for the transmission line discussed in § 81 in a region where the atmospheric pressure is 70 cm. of mercury and the temperature averages 20 deg. cent.

45. Determine the line constants per mile per phase at 15° C. of a three-phase 60-cycle aerial power transmission line using solid hard-drawn copper conductors 0.8 inch in diameter spaced triangularly 6 feet apart.

46. Calculate the voltage and current at the generator end of the line, the efficiency of transmission, the voltage regulation, and the charging current of the transmission line of § 81 when the frequency is 25 cycles, all other conditions remaining unaltered.

47. Plot a curve showing the corona loss per mile of the transmission line of § 81 for various operating voltages up to 200 effective kilovolts between conductors. Take the density factor as unity.

CHAPTER X.

POWER STATIONS.

85. Station Load Curves. — The proper design of a power station depends to a large extent upon the characteristics of its output. A curve with ordinates representing the output of a station in kilowatts and with corresponding

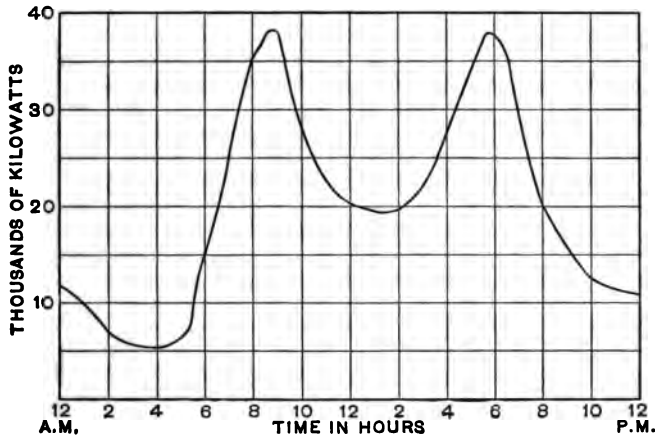

Fig. 107.

abscissæ representing the time of day is termed a *load curve* of the station. Fig. 107 represents a typical load curve for a power station supplying energy for traction purposes. It is characterized by two peaks, which occur at about 8.30 in the morning and 6.00 in the evening respectively, and which last for two or three hours, and by

a very low value during the early morning hours. The peaks are due to the demands of traffic in carrying passengers to business in the morning and returning them to their residences at night. The maximum value of the peak at the power station is less than the sum of the peaks at the different substations; because the latter occur at different times, that is, because of the *diversity factor*. In the morning, the peaks at the substations in the residential districts occur prior to those in the business and manufacturing districts, while the reverse is true in the evening. Furthermore, the average duration of the power-station peaks is greater than characterizes the substation peaks for the same reason. The ordinates of the load curve are greater in winter than in summer because of the necessity for heating and lighting the cars, and often because of the presence and removal of snow. The energy required for heating may be 20 per cent of that required for car propulsion. The shape of the load curve is likely to be entirely different on Sundays and holidays from its shape on week days and may be materially modified by the maintenance of seasonal amusement or recreation resorts. Instantaneous fluctuations in the power output, not shown in the load curve and due to the abnormal currents necessary in the starting of trains, are always present. With few cars in operation the relative magnitude of these fluctuations is greater than when there are many. The amount of fluctuation can be determined with sufficient exactitude from the curve of Fig. 58, which shows the dependence of the ratio of maximum to average current upon the number of cars in operation.

The power-station load curve for a proposed installation can be predetermined with considerable accuracy from the

train-sheet, § 52, of the tentative service to be maintained and the curves of power input to the car, § 43, for different times. The ordinate of a point on the power-station load curve for a given instant is equal to the sum of the inputs to all cars in operation at that instant, divided by the product of the efficiencies of transmission, of conversion, and of distribution, which product usually ranges from 70 per cent to 75 per cent. With urban systems, where congestion of street traffic constantly interferes with regularity of schedules, this method is inapplicable. In such cases a fair estimate of the power-station output in kilowatts at any instant is, however, numerically one-half the rated horsepower of all the motors on cars in service at that instant. This method of estimation is based upon the fact that the continuous current capacity of a railway motor is about one-half its capacity when nominally rated in accordance with the Standardization Rules of A.I.E.E. The average power supplied to a certain number of cars is therefore one-half the rated horsepower of the corresponding motors, and with an efficiency of 75 per cent in transmission from the power station to the cars a kilowatt at the station corresponds to a horsepower at the car.

86. Selection of Generators. — For stations of small capacity supplying energy for short roads it is often economical to use 2200-volt generators, as the cost of wiring is less than for lower voltages and the cost of insulation is less than for higher voltages. Furthermore, this being a standard voltage for lighting generators, there is a complete line of these generators available. For systems where the economic voltage for transmission, calculated under the assumed use of step-up transformers, is of the order 20 kilovolts, standard generators wound for 12 kilovolts and

connected directly to the transmission line will generally prove more economical. For transmitting large amounts of power at higher voltages step-up transformers must be used while the generator voltage should conform with standards such as 6.6 or 11 kilovolts.

The size of a unit, including generator and prime mover, should be such as to entail a minimum annual charge against it, arising from its cost and operation. To reduce the relative losses in a unit it should be operated as nearly as possible at that load which gives a maximum efficiency. Because the designed operating efficiency is generally greatest at about rated load and, because of the characteristics of the load curve, the losses would be least with units of minimum rated capacity. The efficient use of such small units, however, would necessitate frequent starting and stopping of the different units corresponding to the fluctuations of load, and this would require a large force of attendants. Furthermore, the cost, the deficiency, and the required floor space per kilowatt is greater for small units than for large ones, and therefore the proper selection is, by nature, a compromise.

Very small stations are generally located upon cheap land and space economy is of no great importance, whereas the number of attendants must be reduced to a minimum. Furthermore, the cost per kilowatt varies so greatly with the capacity of small units that, if capital is limited, it may be necessary to install but a single unit. For the sake of reliability of service, however, it is undesirable to use less than two units.

For the average station of moderate capacity four units, one of which serves as a reserve unit, to be used in case of failure of another, will generally prove most economical.

The relative values of the early morning and noonday loads, which endure for protracted periods, may, however, make it desirable to use a larger number of units so as to operate at good efficiency during these hours.

Very large stations have been installed in the past with the number of units prescribed by the maximum capacity available. Steam-turbine units are now constructed which have a rated capacity of over 45,000 kilowatts.

According to the standardization rules of A.I.E.E. generators should be able to carry a 25 per cent overload for two hours. If a railway power station were to be equipped with five units, each of rated capacity equal to one-fifth the maximum station load, then in case one should fail the whole load could safely be carried by the remaining four. This is possible because the fifth unit is seldom in service for more than two hours during the peak loads. A reserve unit may thus be dispensed with. If the power factor of the load on the generators be less than unity, the overload capacity may not be sufficient as a substitute for the reserve unit.

87. Types of Prime Movers. — The types of prime movers at present available for electric power stations are steam engines, internal combustion engines, and water wheels. As a rule that type should be employed which will result in a minimum average cost of reliably delivering a kilowatt-hour of energy. To make an equable comparison the point of delivery should be the same in all cases. This will generally require for hydraulic plants that a part or the whole of the expense of the transmission system shall be considered as chargeable to the power station. If the financial hazard associated with the undertaking be large or if capital be limited, it may be necessary to reduce

the first cost, the plant thereafter being burdened with an excess cost of energy production.

Internal combustion engines burning gas or liquid fuel in their cylinders have a high thermodynamic efficiency. The high pressures developed require heavy construction, the high temperatures require cooling systems, and the intermittent release of energy requires heavy flywheels. They therefore cost more than other forms of prime movers, and depreciate in value faster. Furthermore, gas engines have a very limited overload capacity. Reliability in their operation has not been sufficiently established to warrant the recommendation of their adoption as a sole source of power in a station for supplying energy for railways. Yet the Milwaukee and Northern road as well as the Warren and Jamestown road are operated solely from generators driven by gas engines.

88. Power Station Costs. — The annual cost of operating a station is conveniently divided into two parts, namely, *fixed charges* which do not vary with or depend upon the output of the station after it is built and equipped, and *operating expenses* which vary with the output. The fixed charges usually comprise interest, taxes, insurance, rental, depreciation, and obsolescence. Sometimes there is apportioned to the power station a part of the annual administration costs, including office rentals, salaries, and legal expenses. The operating expenses comprise labor or attendance, repairs and maintenance, fuel, water, oil, waste, and other supplies.

STEAM STATIONS.

89. Engines and Turbines.— Steam-driven prime movers may consist of reciprocating engines or turbines, operated with or without exhaust steam condensers. The former are usually either simple or compound and are sometimes classified as high-speed or low-speed, although there is no sharp dividing line in this respect. A speed of 150 revolutions per minute may be assumed as the usual line of division. The proper selection of a prime mover of this type is based upon the first cost of the prime mover and of the rest of the equipment entailed by its use, as well as upon the expenses of maintenance and operation. Data concerning steam prime movers generally include pounds of steam consumed per indicated horsepower-hour or per kilowatt-hour of output, initial and back pressures of the steam, and the mechanical efficiency of the mover. The steam consumption and efficiency vary with the load, as does the efficiency of a generator. With assumed conditions as to pressures and load, the pounds of steam per kilowatt-hour of generator output is to be found by dividing the pounds of steam consumed per indicated horsepower-hour by 0.746 times the product of the generator and prime-mover efficiencies. The steam consumption of reciprocating engines increases somewhat with use, whereas that of turbines remains fairly constant. The steam consumption of Curtis turbines decreases about one percent for each increment of 10 pounds in gauge pressure and one pound per kilowatt-hour per inch of vacuum.

At a given pressure, steam having the minimum temperature consistent with its remaining in the form of a vapor is termed *saturated steam*, and a reduction of its tempera-

ture causes condensation. If saturated steam be removed from contact with water, its temperature may be raised above that of the water from which it was produced. It then acts like an imperfect gas and is termed *superheated steam*. The rise of temperature in degrees Fahrenheit is a measure of the amount of superheat. If steam rises from a surface of water faster than about three feet per second, it carries water with it in the form of spray, and when fine spray is once formed in steam it does not readily settle. The resultant mixed steam is termed *wet steam*. Superheated steam, if homogeneous, cannot be wet, because water particles would of necessity be evaporated under the influence of heat derived from the surrounding steam.

The cyclical changes in the temperature of cylinder walls, accompanying the operation of reciprocating engines, causes *cylinder condensation* losses of heat when it is fed with saturated steam. Such losses are seldom less than 10 per cent and often amount to 40 per cent of the supplied energy, and may be materially reduced by the use of superheated steam. The presence of moisture in the steam passing through a turbine occasions a wear of the turbine blades as the result of impact. It is therefore desirable to supply superheated steam to reciprocating engines on the ground of economy and to turbines on the ground of maintenance. A device used to elevate the temperature of steam above its saturation temperature is termed a *superheater* and may consist of a set of tubes connected in the steam line and subjected to the heat from the fire of the main boiler or from an auxiliary source.

The data contained in the following table give an idea of what may be expected as to the performance of these

types of prime movers. The efficiency of reciprocating engines and of generators has been assumed as 92 per cent and 97 per cent respectively.

STEAM CONSUMPTION.

Type of engine.	Pounds of steam per K.W.H.
SATURATED STEAM:	
Simple noncondensing.....	55
Compound noncondensing.....	35
Simple condensing.....	33
Compound condensing.....	27
Turbines.....	20
SUPERHEATED STEAM:	
Compound condensing.....	14
Turbines.....	15

90. Condensers. — Consider a simple engine run so that the steam after expansion exhausts into the atmosphere; that is, run *noncondensing*. The effective force per unit area of piston, available at any instant for performing work, is the difference between the pressure of the steam on one of its surfaces and the back pressure exerted by the atmosphere at that instant on the other surface. Since the mean effective value of the former may be of the order 50 lb./in.² and the latter is 14.7 lb./in.², a reduction of the latter to 1.7 would theoretically increase the power output 13/50 or 26 per cent. An enclosed device which is adapted to receive the exhaust steam, lower its temperature, and thereby condense it, is termed a *condenser*. Its use materially reduces the back pressure because steam, after condensation, occupies an insignificant portion ($\frac{1}{1700}$) of the space filled by it prior to condensation. In order to cool and condense the steam it must be deprived of

some of the heat associated with it. This may be done by passing it along one surface of a thin metal which is kept cool by water circulated in contact with the other surface or by mixing the steam with a spray of cooling water. A device using the first method is termed a *surface condenser*, and one using the latter is termed a *jet condenser*. The condensing water used with the jet condenser is variously termed, as *injection*, *cooling*, or *circulating* water. To maintain the condenser in operation the condensed water, which has collected in a *hot well*, must be removed by a *wet-vacuum* pump, which may also serve to remove the air which is invariably present as the result of leakage, or absorption in the injection water. To maintain a high vacuum an additional *dry-vacuum* pump is often used for removing the air.

The amount of cooling water required per pound of condensed steam depends upon the vacuum and upon the initial and final temperatures of the cooling water.

Let λ = total heat of the exhaust steam above 32°F. ,
 T_0 = initial temperature of the cooling water,
 $T_1 = \left\{ \begin{array}{l} \text{temperature of the condensed steam (surface),} \\ \text{temperature of the discharge water (jet),} \end{array} \right.$
 T_2 = temperature of the discharge water.

Then the weight of cooling water, W , necessary to condense one pound of saturated steam, is

$$W = \frac{\lambda - T_1 + 32}{T_2 - T_0} \text{ pounds.}$$

Surface condensers cost more than jet condensers, but permit the use of the condensed steam as feed water for the boilers after any oil, which became mixed with it in the engine, has been removed from it. They are there-

fore adapted for use where there is a limited supply of suitable feed water but a superabundance of cooling water, such as results from a location near salt waterways. When the supply of cooling water is limited the use of *cooling ponds* or *cooling towers* permits of the repeated use of the same water, but these arrangements are expensive.

The advisability of installing condensers depends upon whether the annual saving of energy is greater or less than the annual expense entailed by their cost, maintenance, and operation.

A jet condenser is shown in Fig. 108 with parts cut away so as to indicate the interior construction. The exhaust steam enters through the large pipe at the left and the cooling water through the large pipe at the right. The latter is sprayed through the valve in the center, mixes with the steam, condenses it, and both fall into the pipe below. The air-pump is connected with the small pipe at the left. With



Fig. 108.

the surface condenser shown in Fig. 109, the cooling water is passed through the interior of the small tubes and abstracts heat from the exhaust steam, which surrounds the tubes, thereby condensing it. The circulating pump to the right and the vacuum pump to the left are operated by an intermediate auxiliary engine.

91. Boilers. — An essential element in a steam plant is the boiler equipment, and its size and cost depend upon the amount of steam which is to be supplied to the prime movers and to the auxiliaries. A typical form of boiler for use in power stations is shown in Fig. 110, wherein the water to be heated circulates as the result of localized temperature differences, moving to the right in the cylindrical

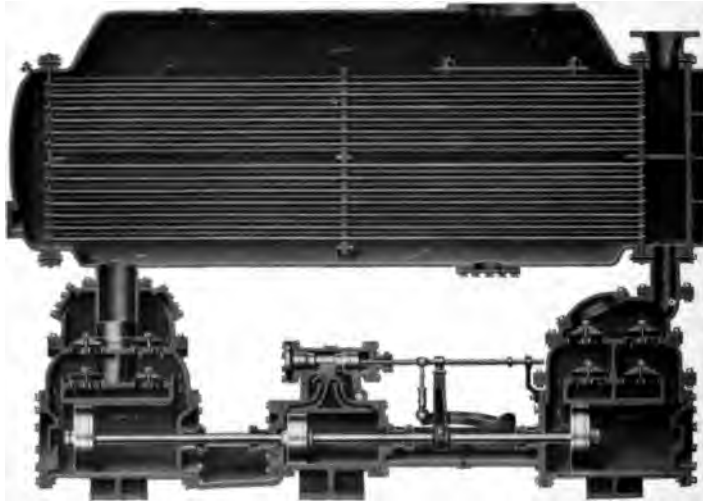

Fig. 109.

drum at the top, and to the left in the *water tubes*, which are enveloped in the hot gases resulting from the combustion of the fuel. These gases ultimately pass through the *damp*er-controlled opening near the top of the right-hand enclosing brick wall, and through a *breeching* to the chimney or stack. Steam is generated and confined under pressure in the upper part of the drum, and is fed through the *nozzle* on top to a *header*, whence it is conducted direct to the prime mover. The capacity of a boiler is rated in horsepower

and the *builder's rating* is based upon a heating surface of 10 to 12 square feet per horsepower. A boiler of one horsepower capacity is considered to be capable of allowing an evaporation of 34.5 pounds per hour of water at 212° F. into steam at atmospheric pressure, and to have an overload capacity of $33\frac{1}{3}$ per cent. If the temperature, t , of the feed water be less than 212°, the steam be x part dry, or the steam be superheated t_s ° F., the delivery of 34.5

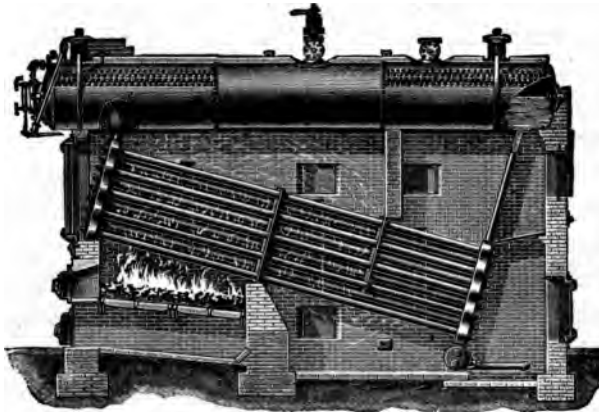

Fig. 110.

pounds of steam per hour under such conditions will require a boiler of more than unit capacity, and to deliver Q pounds of steam per hour the horsepower capacity of the boiler should be

$$\frac{Q}{34.5} \left(\frac{xr + q + Ct_s - t + 32}{970.4} \right) \text{ horsepower,}$$

where r = latent heat of evaporation at the resultant pressure,

q = heat in liquid at this pressure, and

C = mean specific heat of the superheated steam.

The values of the various constants may be found in Engineering handbooks.

The steam consumed in operating auxiliaries such as feed pumps, vacuum pumps, and circulating pumps, ranges from 6 per cent to 15 per cent of that taken by the prime movers. Available boilers are limited in capacity to about 2250 horsepower, and it is common to install smaller ones in batteries of two or more.

92. Feed-water Heaters. — It is undesirable to pump cold water into a hot boiler because of excessive stresses which may result from wide differences in the temperature of adjacent parts of the metal of the boiler. Furthermore, there is a saving of about one per cent in fuel for every 11 degrees elevation in the temperature of the feed water, provided such elevation is produced by heat that would otherwise be lost. The temperature of the feed water may be raised by heat taken from the exhaust steam through the aid of a *vacuum heater* or an *atmospheric heater*, and by heat from the hot flue gases, using an *economizer*.

93. Chimneys or Stacks. — A chimney serves two purposes, namely, to carry off the obnoxious gases resulting from combustion, and to produce a *draft* which will give a sufficient supply of oxygen for combustion. The former requires an adequate cross section and the latter an adequate height of chimney. Experience shows that the draft pressure, measured in inches of water as compared with atmospheric pressure, should be from 0.5 to 1.5 inches, depending upon the character and size of the fuel to be used, and upon the quantity to be burned per square foot of grate surface. Heights above the grate, which have given satisfactory results in practice with plants of moderate capacity employing different fuels, are given in the following table:

HEIGHTS OF CHIMNEYS.

Fuel.	Height in feet.
Free-burning bituminous.....	80
Anthracite, large sizes.....	100
Slow-burning bituminous.....	120
Anthracite buckwheat.....	150
Anthracite slack.....	175

The ascending gases in a chimney are retarded by friction in the vicinity of the walls, and the equivalent cross section A of a round chimney is therefore generally taken as that corresponding to a diameter four inches less than the real internal diameter of the chimney. Assuming a coal consumption of five pounds per horsepower-hour, a chimney of height h feet, properly to carry off the gases from boilers of P horsepower, should have an equivalent cross section of

$$A = \frac{0.3 P}{\sqrt{h}} \text{ square feet.}$$

Chimneys are constructed of steel, reënforced concrete, or masonry. Steel chimneys weigh less, cost less, require less space, expose less surface to the wind than other forms, and are more efficient because they are air-tight. They, however, depreciate more rapidly because of rust and because of the corrosive influence of the flue gases.

Sometimes short chimneys are used in connection with *mechanical draft* apparatus, consisting of either an exhaust fan in the smoke flue or a mechanical or steam-jet blower underneath the grate bars. An *induced draft* is produced by the former and a *forced draft* by the latter. The advisability of installing mechanical draft apparatus is dependent upon the results of an economical comparison with

the saving resulting from the lessened necessary height of chimney.

94. Buildings. — Power-station buildings may be constructed of wood, brick, reënforced concrete, or stone. Wood is used only for very small stations and stone only for elaborate stations. If a single building is used for housing the boiler plant as well as the generating plant, the

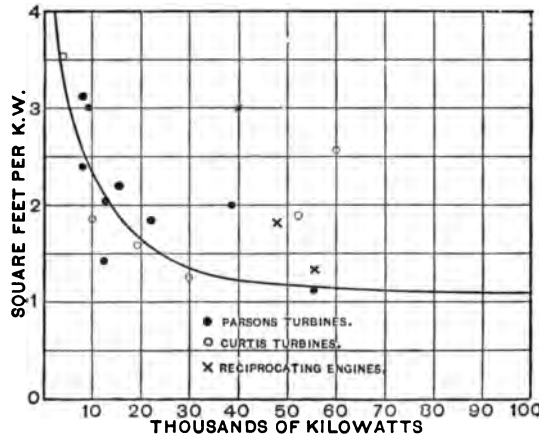

Fig. III.

two should be separated by a brick wall with no openings in it which will allow dirt to pass through from the boiler room to the engine room. The boilers and the units which are supplied with steam from them should be on opposite sides of the dividing wall and so placed as to reduce the length of steam piping to a minimum. The height of both rooms should be ample, to permit the use of lifting machinery and the replacing and repairing of boilers. The building should be well lighted, well ventilated, of fire-proof construction, and arranged with a view to extension in case of growth of demanded output.

The floor space required for turbines is materially less than that for reciprocating engines of the same capacity and the foundations can be much lighter. Where the cost of land is great a considerable saving may be effected by placing turbines on a floor above the boiler room. The station is then termed a *double-deck* station. The space required for passageway around units is greater per kilowatt for small units than for large ones. The curve of Fig. 111 is based upon existing plants, and shows the average floor space allowed per rated kilowatt in terms of the total capacity of a plant.

95. Arrangement of Apparatus.— It is customary to arrange the apparatus in a steam-power station so that the path of energy is as short as possible. The coal is therefore received and delivered to the boilers at one end of the station and the electrical energy is delivered to the line from the generators at the other end. Figs. 112 and 113 show an elevation and floor plan of the Winona Interurban Railway Power House which has a capacity of 1200 K.W. The output is supplied at 33,000 volts from two banks of three transformers, each of 200 K.W. capacity and stepping the voltage up from 2300 volts. There are two 600-K.W. 25-cycle, 2300-volt generators, each directly connected to a cross-compound engine guaranteed to have a full-load steam consumption not to exceed 14.1 pounds per indicated horsepower-hour at 140 pounds pressure and 26 inches of vacuum. Each engine is supplied with a jet condenser. Steam is supplied by four boilers, arranged in batteries of two each, there being 3000 square feet of heating surface provided in each unit. It will be noted that a transformer-converter substation, for supplying 600-volt direct current to the distribution circuits in the immediate vicinity is housed under the same roof.

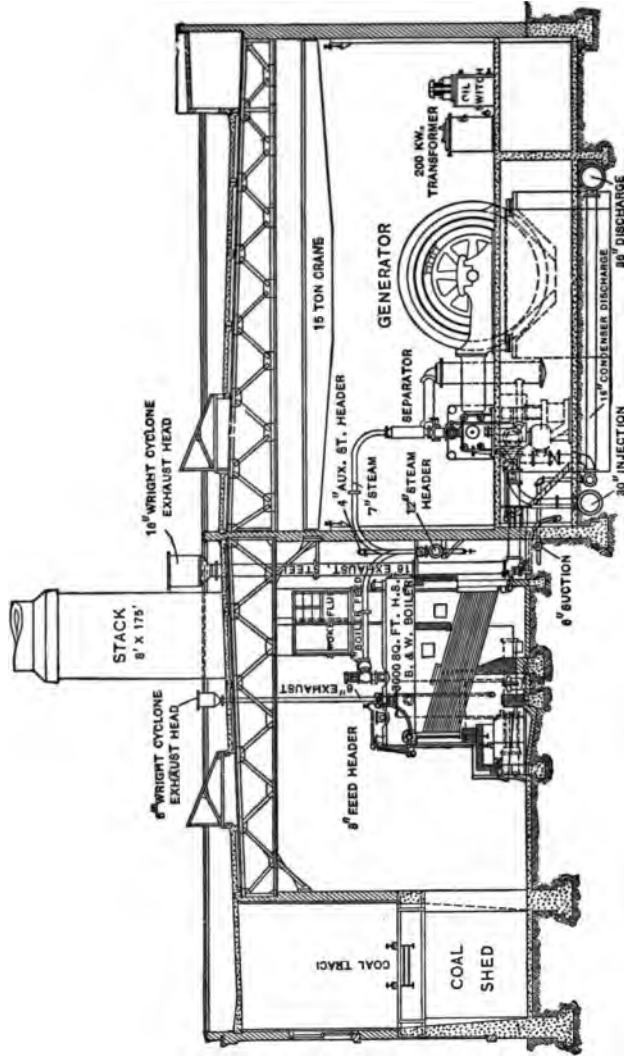

Fig. 113.

Fig. 114 shows a cross section of the Port Morris Power House of the New York Central Railroad, which is equipped with Curtis steam-turbine units and surface condensers.

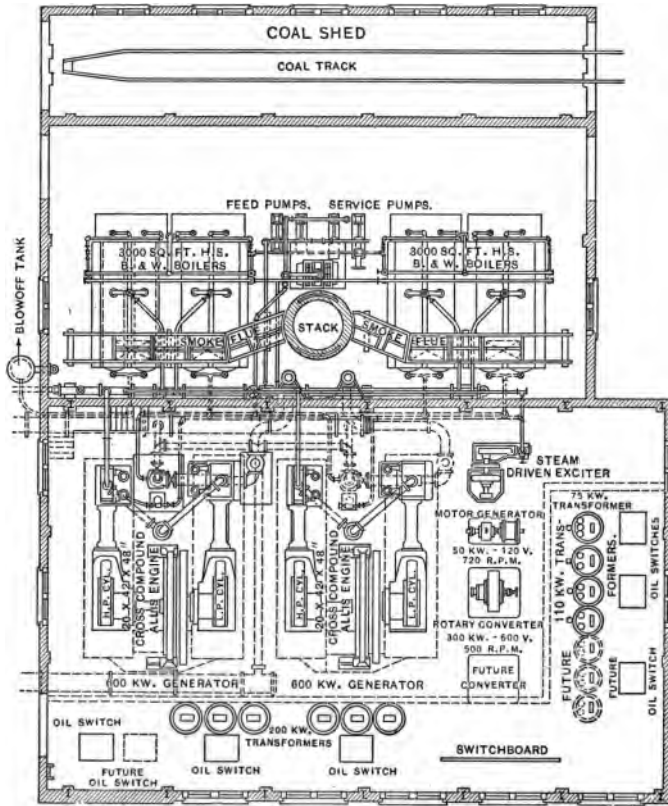

Fig. 113.

The very complete system of labor-saving apparatus for conveying coal and removing ashes and its method of operation is clearly shown.

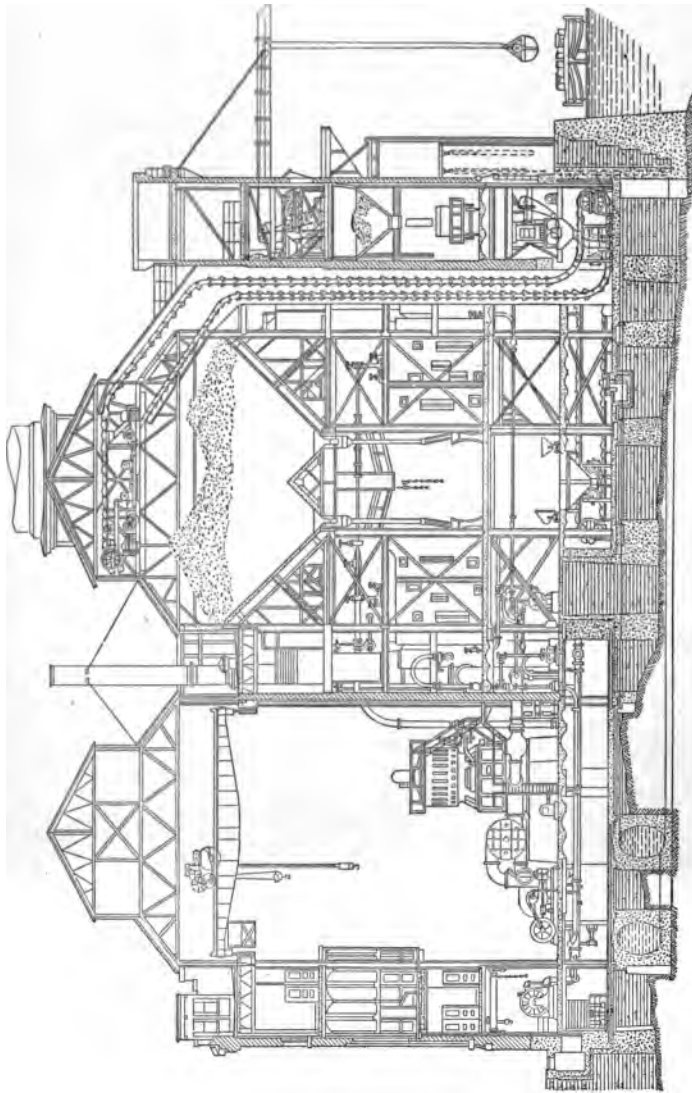

Fig. 114.

POWER-PLANT COSTS PER KILOWATT.

	Min.	Max.
1. Real estate.....	\$3.00	\$7.00
2. Excavation.....	.75	1.25
3. Foundations, reciprocating engines.....	2.00	3.00
4. Foundations, turbines.....	.50	.75
5. Iron and steel structure.....	8.00	10.00
6. Building (roof and main floor).....	8.00	10.00
7. Galleries, floors, and platforms.....	1.50	2.50
8. Tunnels, intake and discharge.....	1.40	2.80
9. Ash storage pocket.....	.70	1.50
10. Coal hoisting tower.....	1.20	2.00
11. Cranes.....	.40	.60
12. Coal and ash conveyors.....	2.00	2.75
13. Ash cars, locomotives, and tracks.....	.15	.30
14. Coal and ash chutes.....	.40	1.00
15. Water meters, storage tanks, and mains.....	.50	1.00
16. Stacks.....	1.25	2.00
17. Boilers.....	9.50	11.50
18. Boiler setting.....	1.25	1.75
19. Stokers.....	1.30	2.20
20. Economizers.....	1.30	2.25
21. Flues, dampers, and regulators.....	.60	.90
22. Forced draft blowers, air ducts.....	1.25	1.65
23. Boiler, feed, and other pumps.....	.40	.75
24. Feed-water heaters.....	.20	.35
25. Piping, traps, and separators.....	3.00	5.00
26. Pipe covering.....	.60	1.00
27. Valves.....	.60	1.00
28. Main engines, reciprocating.....	22.00	30.00
29. Exciter engines, reciprocating.....	.40	.70
30. Condensers, barometric or jet.....	1.00	2.50
31. Condensers, surface.....	6.00	7.50
32. Electric generators.....	16.00	22.00
33. Exciters.....	.60	.80
34. Steam-turbine units, complete.....	22.00	32.00
35. Converters, transformers, blowers.....	.60	1.00
36. Switchboards, complete.....	3.00	3.90
37. Wiring for lights, motors, etc.....	.20	.30
38. Oiling system.....	.15	.35
39. Compressed air system and other small auxiliaries.....	.20	.30
40. Painting, labor, etc.....	1.25	1.75
41. Extras.....	2.00	2.00
42. Engineering expenses and inspection.....	4.00	6.00

96. Cost of Steam Stations. — The table on the preceding page, due to H. G. Stott, includes the approximate cost per kilowatt of the various elements entering into the cost of a steam plant. A fair average cost per kilowatt is \$100 for plants using reciprocating engines and \$80 for those using steam-turbine units.

97. Operating Expenses. — Data concerning twenty-three stations of moderate capacity, using mostly bituminous coal ranging in price from \$2.75 to \$5 per gross ton, and all operated condensing, has been published recently by E. F. Tweedy. Fig. 115 shows the operating costs

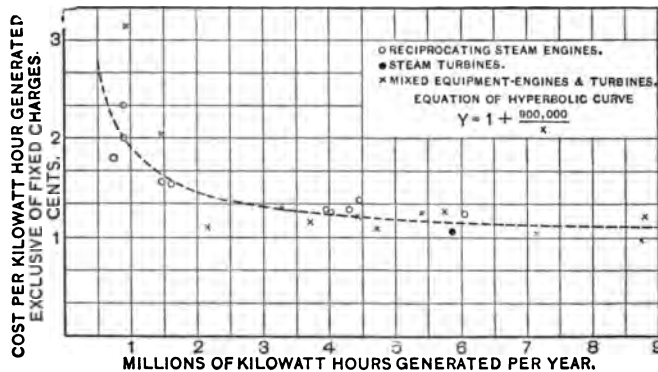

Fig. 115.

per kilowatt-hour in terms of total annual outputs. The highest load factor based upon rated capacity was 0.23, the lowest 0.11, and the average 0.17. The coal consumed per kilowatt-hour ranged from a little over 3 pounds for the larger plants to about 5 pounds for the smaller ones. The station rating in kilowatts per man employed in operating the station, ranged from about 100 K.W. for the

smallest stations to 250 K.W. for the largest. Fig. 116 shows the percentage distribution of operating costs among fuel, labor, and miscellaneous items.

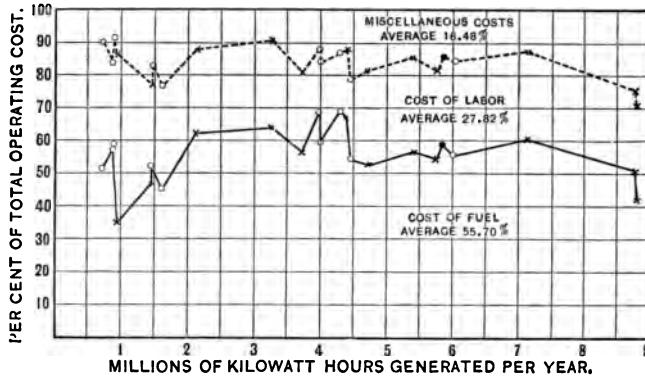

Fig. 116.

HYDRAULIC STATIONS.

98. Turbines. — In procuring mechanical energy from water power two classes of turbines or water wheels may be utilized in conformity with American practice; namely, the *reaction turbine* and the *impulse wheel*.

The reaction or pressure turbine of the *mixed-flow* type is applicable for low and moderate heads, say up to 150 feet, although this type has been used for heads up to 600 feet. It consists of a rotating wheel or *runner* carrying vanes or buckets to which water under pressure is delivered radially inward by means of stationary guide vanes surrounding the wheel, and from which the water is discharged partially in an axial and partially in a radial direction. Torque is developed by reaction, due to changing the direction of water flow.

As the buckets and wheel passages are always completely filled with water, it is not necessary to mount the turbine at the level of the discharged or *tail water* in order to realize the total head, if an air-tight *draft tube* leading from the wheel outlet down somewhat below the level of tail water be provided; for the falling water in the draft tube from the turbine creates a vacuum that is effective in sucking the water through the turbine, and which is equivalent to increasing the pressure of the inflowing water. Reaction turbines may be placed at any level up to about 20 feet above the *tail race* without loss of head.

The power developed by a turbine under a given head is regulated by varying the amount of water admitted to the runner by means of *gates*. There are various types of gates, including the so-called *cylinder*, *register*, and *wicket* gates, the last being the most used. In this type the guide vanes are pivoted so that all may simultaneously approach or recede from their neighbors by the rotation of a single regulating shaft.

In order to neutralize the end thrust due to the axial pressure of the water, as well as to secure higher speeds under a given head, it is common to place two turbine runners — of correspondingly reduced diameter for the same total power output — on a single shaft. Sometimes four and even six runners are coupled together to constitute a single unit. Fig. 117 shows a 9000 horsepower Allis-Chalmers horizontal twin turbine with the runners dismantled. The water enters through the wicket gates at the ends and within the bearings, passes through the wheels, and emerges at the bottom.

Impulse wheels, suitable for heads above 150 feet, comprise a number of buckets into which water is directed



Fig. 117.

through one or more nozzles at a velocity equal to $\sqrt{2gH}$ feet per second, where g is the acceleration due to gravity = 32 ft. per sec. per sec., and H is the head or height of water in feet. Each bucket forms two cups divided by a central ridge which separates the impinging water into two parts, each part being deflected backward to one side of the

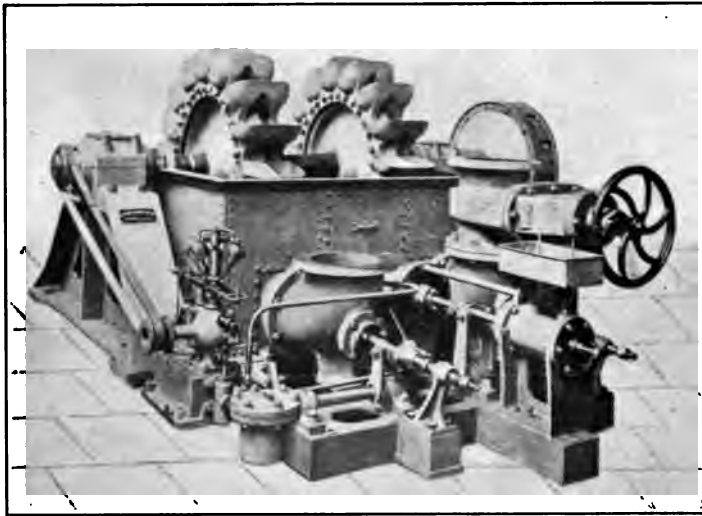

Fig. 118.

wheel by the bucket. The effective head is that from the level of headwater to the nozzle, the head from the latter to the tailwater being lost; consequently the impulse wheel should be placed as low as possible. The flow of water is regulated by needle valves or by deflecting the nozzle. Fig. 118 shows a twin Pelton water wheel with its "hydraulic relay" governor.

Governors are used on both types of water turbines for automatically effecting the opening and closing of the regu-

lating gates or for deflecting the jet from the buckets of impulse wheels. As the force required for this purpose is very large, it is evident that the centrifugal ball governor cannot directly control the gate opening, but must do so through the intervention of a *relay*. Two general types of relay are used: *mechanical relays*, which derive power for their operation from the water wheel by means of gears, pulleys, or other mechanical devices, and *hydraulic relays*, which are operated either by the pressure of water taken from the "penstock" or other source, or by oil supplied under high pressure from a reservoir.

Turbines or water wheels are ordinarily direct-connected to the electric generators, but may be either geared or belted thereto, there being one prime mover for each generator, and one or more additional turbines for the exciter units. Four generator units is considered the minimum number allowable for the attainment of a reasonable degree of insurance against shut-down.

Having determined the number and size of the electric generating units from a study of the load curves on the power station, the size of the prime mover in horsepower is found by dividing the kilowatt rating of the generator by 0.746 times the efficiencies of the generator and mover. The efficiency of large generators at full load may be taken as between 93 and 97 per cent. The efficiency of turbines and water wheels is conventionally taken as 80 per cent, although efficiencies as high as 86 per cent have been attained. Some of the turbines of a hydroelectric power house should have a high efficiency at low-gate opening and others should have their greatest efficiency at full-gate, so as to realize a fairly high all-day plant efficiency under widely varying loads. Representative efficiency curves of

two modern reaction turbines at various gate openings are shown in Fig. 119.

The power developed by a turbine or impulse wheel depends upon the quantity of water passing through it in

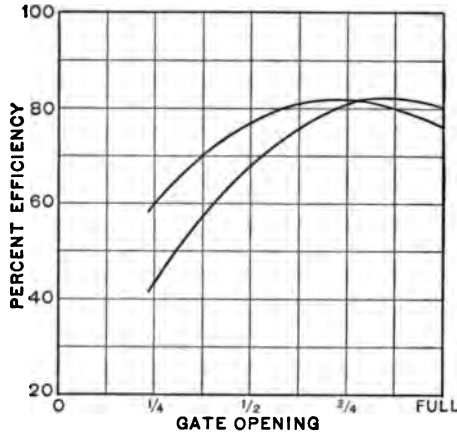

Fig. 119.

unit time, upon the available head of water, and upon the turbine efficiency, ϵ , and is

$$P = \frac{62.4 q \epsilon H}{550} = \frac{q \epsilon H}{8.81} \text{ horsepower,}$$

where q is the discharge in cubic feet per second and which may be expressed empirically as

$$q = K D^2 \sqrt{H},$$

wherein D is the diameter of the runner in feet, and K is an experimental constant of discharge dependent upon the design of the turbine. Therefore

$$P = \frac{K D^2 \epsilon H^{\frac{3}{2}}}{8.81} \text{ horsepower,}$$

whence the proper wheel diameter for a given head is

$$D = \sqrt{\frac{8.81 P}{KH^{\frac{3}{2}} \epsilon}} \text{ feet.} \quad (1)$$

The values of K vary widely among the different designs of various manufacturers, but most values thereof lie between 2.3 and 3.5 for reaction turbines, and between 0.015 and 0.024 for impulse wheels.

For a given turbine the speed of the runner varies with the square root of the head. Let τ be the ratio of the peripheral velocity of the buckets to the theoretical velocity that water would acquire in falling freely a height equal to the head of water. Then the speed of the wheel in revolutions per minute is

$$V = \frac{60 \tau \sqrt{2gH}}{\pi D} = 153 \frac{\tau H^{\frac{1}{2}}}{D}. \quad (2)$$

The values of τ range from 0.65 to 0.93 with different designs of reaction turbines and between 0.43 to 0.51 with impulse wheels. Having determined the turbine speed for a given head of water, the multipolarity of the alternators for the generation of electromotive forces of definite frequency becomes known.

As an illustration of the foregoing, determine the proper number of poles for a 2000 K.W., 60-cycle, three-phase alternator which is to be driven by a Pelton water wheel on a head of 970 feet, the constants of the wheel being $K = 0.019$, $\tau = 0.505$, and $\epsilon = 0.83$. Taking the alternator efficiency as 92 per cent, the rating of the prime mover is

$$\frac{2000}{0.746 \times 0.83 \times 0.92} = 3500 \text{ horsepower and the diameter of}$$

the water wheel is $\sqrt{\frac{8.81 \times 3500}{0.019 (970)^{\frac{3}{2}} 0.84}} = 8.0$ feet. Therefore

its speed is $1\frac{1}{8}^2 \cdot 0.505 \sqrt{970} = 300$ revolutions per minute. At this speed there must be 24 poles for the production of 60-cycle currents.

99. Water-power Development. — In any hydraulic development the water must be conducted from some source to the wheels by means of a *head-race*, and discharged from the turbines into the tail-race at a lower level. Two general types of water-power development are discernible which usually characterize respectively low-head and high-head developments; namely, (1) where the entire head is utilized at the dam, the power station being located at one end thereof; (2) where long *pipe lines*, *canals*, or *flumes* are required to transfer the water from the intake at the *headworks* to the station, this distance being only sufficiently long to secure for a given amount of water a head which will enable the generation of the required power.

(1) The object of a dam is to concentrate the fall of a stream so that the water power becomes available by the elevation of the water surface. That portion of a dam over which excess water pours is called the *spillway*, and this must be sufficiently long to allow escape of the water in times of heavy flood without undue rise in level of the water in the reservoir above the dam. It is essential that the dam have a solid foundation, that it be stable against overturning and be water-tight, and that it be so constructed as to prevent washing out of the river bed and banks below it and erosion of the dam itself. Dams may be constructed of timber, masonry, or reënforced concrete. They must be equipped with *drain* or *sluice gates* for the purpose of draining the reservoir above them as well as for assisting in the discharge of water during the heaviest floods. The surface of the reservoir may be raised at

times by means of *flashboards*, which collapse automatically upon excessive rise of water.

A plan of a typical low-head hydraulic development is illustrated in Fig. 120, which shows the Johnsonville development of the Schenectady Power Company. This dam causes the flooding of 850 acres, thereby giving a storage

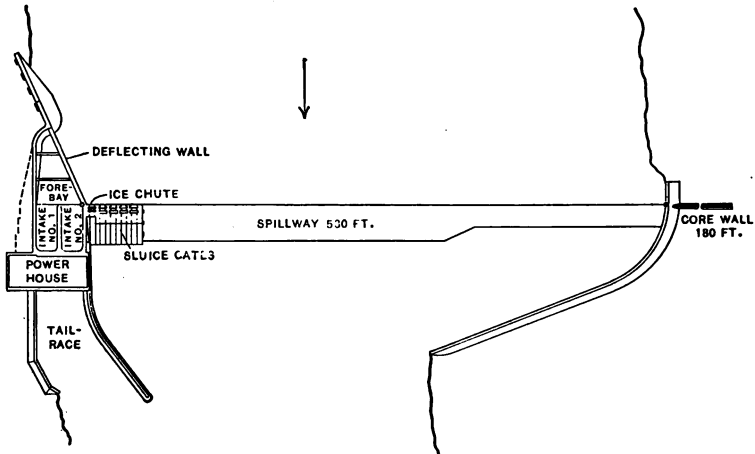

Fig. 120.

capacity or *pondage* of about 350 million cubic feet. Fig. 121 shows the power house and sluice-gate masonry of this development, looking upstream.

The power furnished by a given stream may be increased by a suitable reservoir, for the water impounded during the rainy seasons may be partially drawn off during time of low water. The water available for pondage is limited, however, since the level of head water can only be lowered a comparatively small amount without impairing the output and efficiency of the plant.

Water is led from the head-race or the reservoir through

suitable hand- or motor-operated *head gates* to the *forebay* and from there to the *wheel pits*. The water in entering the wheel pit from the head-race usually passes through a *trash rack* consisting of narrow iron bars, the function of which is to prevent large floating objects from entering the turbines. Open wheel pits are usual for heads up to 30 feet, whereas closed flumes or *penstocks* leading from the



Fig. 121.

head-race to the wheel pits are utilized for higher heads. It is desirable to set the turbines in separate pits so that one or more may be temporarily shut down without interfering with the operation of the station.

A cross-sectional view of the Rocky Creek Power House of the Southern Power Company is shown in Fig. 122, which also illustrates the construction of the penstock and draft tube for each turbine, and the water-tight stuffing box between the wheel pit and the generator room.

Fig. 123 shows the interior of the Rainbow Station of the Great Falls Power Company, Montana. Each of the six 3500 K.W. alternators is driven by a 6000 H.P. reaction turbine with two runners, each runner being enclosed in a separate spiral casing fed by a separate 8-foot steel



Fig. 123.

penstock from a *balancing reservoir* and discharging into a common draft tube.

(2) High-head developments require long canals or pipe lines for conveying water from the intake to the power house. Level canals may be constructed along the hillside to a point above the power station, and from there the water can be passed down to the water wheels through a

penstock. It is usually cheaper, however, to use a pipe line which need not be level but can follow the contour of the land. Wood, cast-iron, or riveted wrought-iron pipe is used for such purposes. The transmission of water through pipes or canals is accompanied by a reduction in the available head, the extent of which depends upon the size of the pipe or canal. This loss of head can be computed from expressions given in most books on Hydraulics.

Provision must be made to prevent injury to penstocks or pipe lines which might occur when the turbine gates or water-wheel nozzles are regulated too quickly. Automatic *relief valves* of sufficient area may be employed at the lower end of the pipe, or either *standpipes* or *surge tanks* may be used to alter the velocity of the water in the pipes.

Fig. 124 gives a sectional view of a typical power house in which impulse wheels are installed. Speed regulation of the prime movers is accomplished by deflecting the nozzles past the buckets and allowing part of the water to impinge upon heavy metal deflector plates.

Frequently hydraulic developments have auxiliary steam or gas engine plants to supplement the water power during the dry seasons or during periods of peak loads.

100. Cost of Development. — The cost of a proposed hydraulic development depends largely upon the extent to which the stream flow is to be developed, upon the nature and remoteness of the power market, as well as upon various topographical, geological, and meteorological conditions of the locality. The decision as to the commercial feasibility of a proposed water-power development must embrace a careful study of all such factors which influence water supply, of the available head and its variations, of the power available with and without pondage, of the

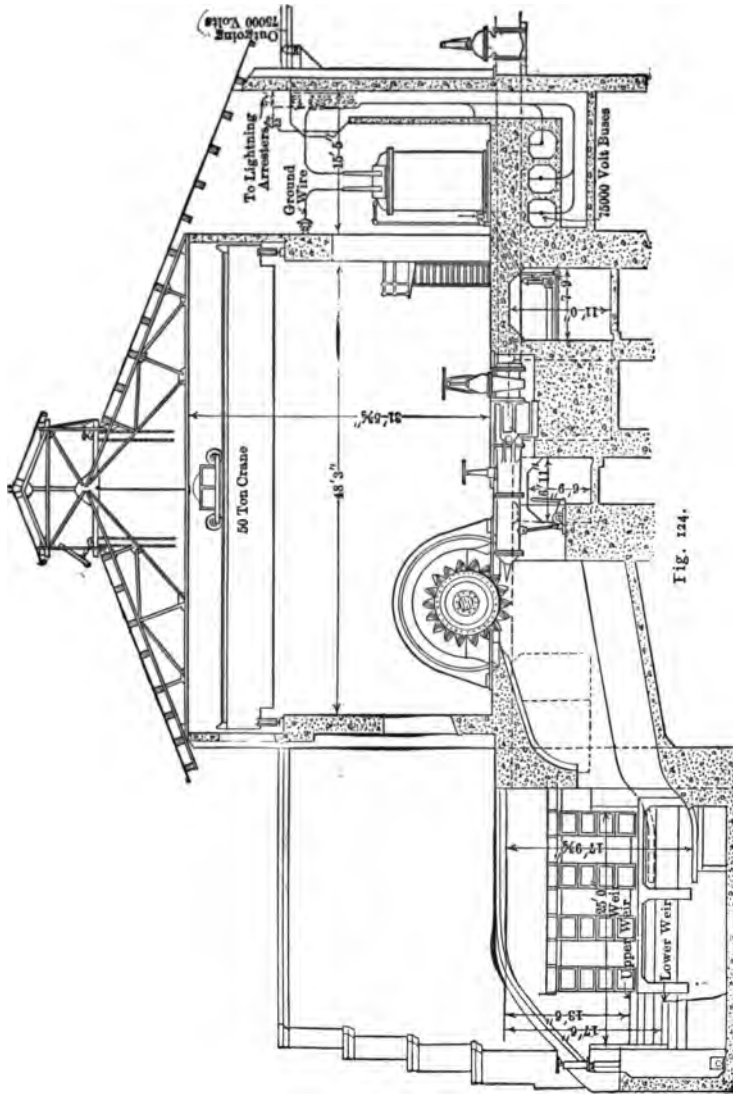

Fig. 124.

location and extent of the hydraulic construction and power house, of the probable market for the power generated and its load factor, and the desirability of auxiliary power.

Rough estimates in terms of generator capacity of the cost of turbine equipments may be derived from Figs. 125 and 126, which embody data from existing installations.

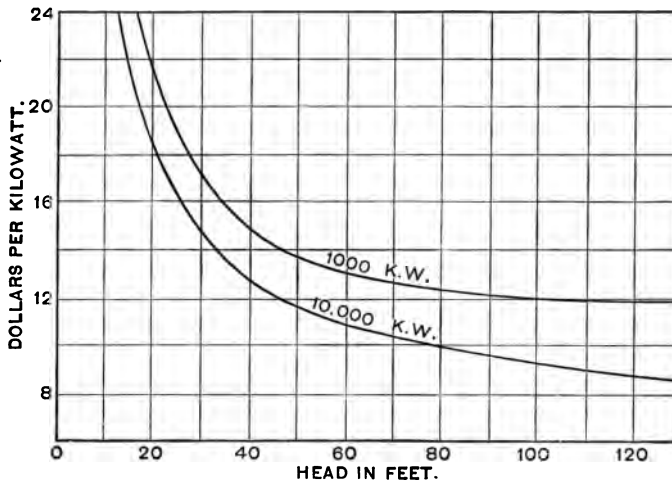

Fig. 125.

The figures refer to reaction turbines and impulse wheels respectively, and include extra movers for exciter units, governors, and cost of erection.

The following table, given by O. S. Lyford, gives the itemized cost (estimated or actual) per kilowatt of generator capacity of seven separate water-power developments in the same general district in our southeastern states, these powers being developed with heads varying from 30 to 120 feet, and with generator capacity varying from 10,000 to

TRACTION AND TRANSMISSION.

COSTS OF HYDROELECTRIC DEVELOPMENTS PER KILOWATT OF INSTALLED GENERATOR CAPACITY.

Plants.	A	B	C	D	E	F	G	Average proportional cost.
Land and water rights.....	\$14.10	\$12.86	\$8.89	\$14.20	\$22.22	\$13.07	\$15.00	10.1
Hydraulic construction (dam, canals, flumes, head gates, etc).....	35.00	43.41	49.50	44.53	51.30	62.42	56.71	34.5
Power-house building and substructure.....	14.00	13.95	13.00	9.05	7.76	7.84	7.56	7.4
Hydraulic equipment.....	21.00	22.73	19.20	13.85	14.50	13.53	12.50	11.9
Power-house electrical equipment.....	17.20	6.26	18.30	9.00	20.70	17.50	28.50	11.9
Transmission line, including right of way.....	5.72	6.51	9.75	7.55	6.82	8.40	8.40	5.4
Substation buildings and equipment.....	10.00	6.94	4.58	4.45	15.67	14.58	12.00	6.9
Distribution system.....	6.30	5.90	5.54	4.75	8.40	6.18	6.16	4.0
Interest during construction.....	5.90	7.36	6.14	6.30	7.00	6.87	6.84	4.2
Engineering.....	3.70		6.20	4.45	5.77	7.48	6.84	3.7
General and legal expenses.....								
Total cost per generator kilowatt.....	\$132.92	\$120.02	\$141.10	\$118.13	\$160.14	\$157.87	\$160.51	100.0

30,000 K.W. The appended column gives the average of the proportional costs of the general groups for the seven plants.

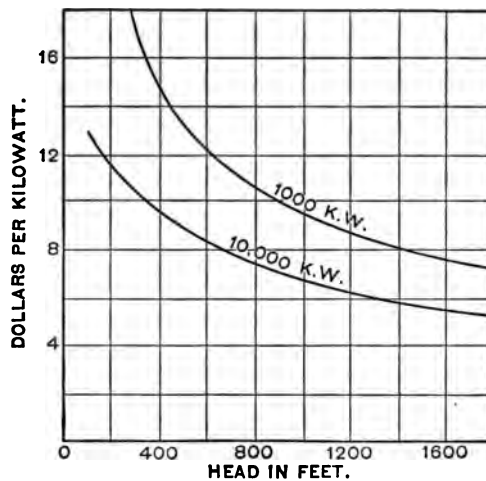

Fig. 126.

101. Depreciation and Obsolescence. — It is difficult to predetermine with accuracy the cost of repairs essential to maintain the various parts of an installation in operating condition, the time that these parts will endure before it becomes unwise to repair them, and the time which will elapse before it will prove more economical to substitute for them more efficient parts. It is necessary, however, to attempt to make such predeterminations in order to carry out an economic design. The following values in reference to hydraulic plants are those given by Dr. Cary T. Hutchinson. He also states that the general consensus of opinion as to the depreciation of steam generating plants is that it amounts to from 5 per cent to 7.5 per cent, with an additional like value for obsolescence. The basis of the follow-

ing table is the assumed life and annual charges compounded at the rate of 4.5 per cent. The depreciation in terms of the total cost assumes that the cost of the power house, the transmission line, and the substation amounts to but 57 per cent of the total cost.

DEPRECIATION RATES.

Item.	Proportional cost.	Life years.	Annual amount for depreciation in per cent of total cost.
POWER HOUSE:			
		[19]	
1. Stop logs, gates, and other wood exposed to air and water.....	0.80	5	0.146
2. Flooring, roofing and hardware, and miscellaneous fixtures....	9.80	15	0.472
3. Tile wainscoting, sewage, plumbing system, and metal window frames, etc.....	2.45	15	0.118
4. Electric light and telephone....	0.80	10	0.065
5. Switchboard equipment.....	4.35	10	0.355
6. Cables and heavy wiring.....	3.90	10	0.318
7. Cranes.....	1.25	15	0.060
8. Water wheels.....	33.75	25	0.757
9. Water-wheel governors.....	2.90	10	0.235
10. Generators and transformers....	40.00	25	0.898
	100.00		3.423
TRANSMISSION LINE:			
		[26]	
1. Right of way.....	45.		
2. Towers.....	18.4	15	0.885
3. Special structures.....	5.1	10	0.415
4. Insulators.....	2.1	10	0.170
5. Copper.....	23.7	25	0.530
6. Installation.....	5.7		
	100.0		2.000
SUBSTATION:			
		[20]	
1. Land.....	6.0		
2. Buildings.....	30.	25	0.67
3. Transformers.....	40.	20	1.28
4. Switches, etc.....	16.	10	1.29
5. Installation.....	8.		
	100.		3.24

102. Relative Operating Expenses. — The following table, due to H. G. Stott, is applicable to plants having a maximum load of over 30,000 K.W., and gives operating expenses and probable fixed charges based upon 5 per cent interest, 1 per cent for taxes and general administrative expenses, and 5 per cent amortization or obsolescence in the steam and hydraulic plants.

RELATIVE COSTS PER KILOWATT-HOUR.

Items.	1 Reciprocating engines.	2 Steam turbines.	3 Reciprocating en- gines and low- pressure turbines.	4 Gas engines.	5 Gas engines and steam turbines.	6 Hydraulic movers.
MAINTENANCE						
1. Engine room, mechanical.....	2.50	0.51	1.55	5.18	2.84	0.51
2. Boiler or producer room.....	4.65	4.33	3.55	1.16	1.97
3. Coal-and ash-handling apparatus	0.58	0.54	0.44	0.20	0.20
4. Electrical apparatus.....	1.13	1.13	1.13	1.13	1.13	1.13
OPERATION						
5. Coal.....	61.70	55.53	52.44	26.52	25.97
6. Water.....	7.20	0.65	0.61	3.60	2.16
7. Engine-room labor.....	6.75	1.36	4.06	6.76	4.06	1.36
8. Boiler- or producer-room labor.	7.20	6.74	5.50	1.81	3.05
9. Coal- and ash-handling labor..	2.28	2.13	1.75	1.14	1.14
10. Ash removal.....	1.07	0.95	0.81	0.54	0.54
11. Electrical labor.....	2.54	2.54	2.54	2.54	2.54	2.54
12. Engine-room lubrication.....	1.78	0.35	1.02	1.80	1.07	0.20
13. Engine-room waste, etc.....	0.30	0.30	0.30	0.30	0.30	0.20
14. Boiler-room lubrication, etc....	0.17	0.17	0.17	0.17	0.17
Relative operating cost, per cent....	100.00	77.23	75.87	52.94	47.23	5.94
Relative investment, per cent.....	100.00	75.00	80.00	110.00	96.20	100.00
Probable average cost, per K.W.(\$)	125.00	93.75	100.00	137.50	120.00	125.00
Probable fixed charges.....	11%	11%	11%	12%	11.5%	11%

103. Costs per Kilowatt-hour. — The average annual cost per kilowatt-hour of output depends upon the annual

load factor and upon the type of an installation. The annual load factor is the ratio of the annual output in kilowatt-hours to 8760 times the *maximum power* of the installed apparatus in kilowatts. Since the fixed charges are dependent upon the rated capacity but independent of the

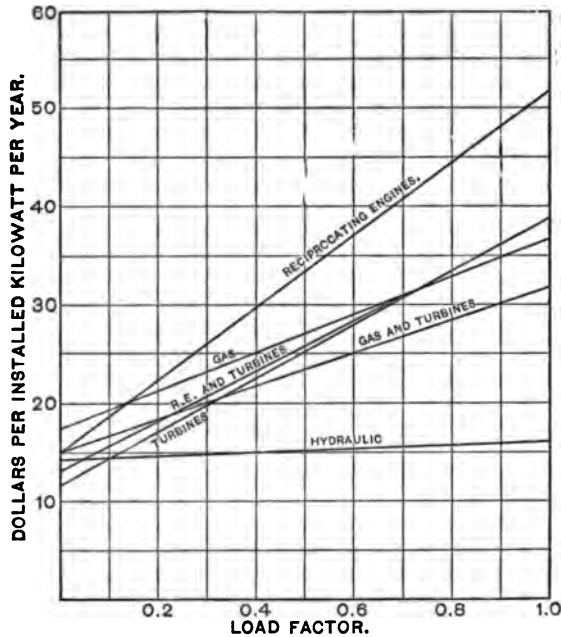

Fig. 127.

output, whereas the operating expenses are dependent upon the latter and independent of the former, the cost per kilowatt-hour of output will be a minimum for a load factor of unity. Furthermore, for a typical railway load of a given maximum demand the rating of the power-station equipment necessarily installed to meet this demand differs with the type of the installation. This is due to differences in

overload capacity. The necessary capacity progressively increases as the type changes from steam to gas and steam again to hydraulic or to gas alone.

For a complete discussion of this subject the reader is referred to Mr. Stott's paper (Trans. A. I. E. E., xxviii, p. 1479), from which Fig. 127 is taken. This figure shows the dependence of the total annual cost per installed kilowatt upon the load factor and the type of plant. The titles associated with the various lines refer to the columns in the table of the preceding article, each of which represents a definite type of installation. A low grade of coal, costing \$1.50 per ton and giving 11,000 B.t.u. per pound, has been assumed. The average cost per kilowatt-hour may be determined by dividing the value of any ordinate by 8760 times the corresponding load-factor.

PROBLEMS.

48. Determine the proper size and number of steam turbo-generator units for a power station having a load curve of the form indicated in Fig. 107 but with ordinates of half the value. What would be the probable number of daily hours of operation of each unit?

49. If the turbines of problem 48 consume 17 pounds of dry saturated steam at 175 pounds gauge pressure per kilowatt-hour and if the auxiliaries use 10 per cent of the total steam generated, how many boilers should be installed per unit and what should be the horsepower of each? Assume the temperature of feed water to be 80° F.

50. Determine the diameter of the runners for a twin reaction turbine to operate on a 100-foot head for a 5000-kilowatt, 25-cycle, three-phase alternator, whose efficiency is 96 per cent. The constants of the turbine are

$$K = 3.0$$

$$\tau = 0.74$$

$$\epsilon = 0.85$$

INDEX.

- Acceleration, 22.
 - automatic, 108.
 - curve, 53, 57.
 - rates, changes in, 126.
- Adequacy of copper distribution, 150.
- Adhesion, coefficient of, 50.
- Adjustment of speed curves, 66.
- Alternating-current control, 90.
 - distribution, 164.
 - motors, 28.
 - substations, 166.
- Aluminum-cell arrester, 256.
- Annual car-miles operated, 5.
- Apparatus, arrangement of station, 189, 275.
- Arc suppressor, 257.
- Arresters, lightning, 209, 254.
- Atmospheric heaters, 272.
 - potential differences, 252.
- Attenuation constant, 238.
- Automatic acceleration, 108.
 - substations, 188.
- Auxiliary feeders, 151.
 - storage batteries, 188.
- Average current per car, 112.

- Batteries, storage, 188.
- Bearing friction, 15.
- Boilers, 270.
- Bonds, track, 156.
- Boosters, 152.
- Braking, 23.
 - curve, 52, 58.
 - energy lost in, 126.
- Branches in roadway, 139.

- Cables, resistance of, 221.
- Capacity of lines, 230.
 - of motors, 51.
- Car-body, types of, 9.
 - cross sections, 17.
 - equipments, weights of, 55.
- Car-mile, earnings per, 6.
 - miles, annual, 5.
 - number of, for urban road, 4.
 - propulsion, tractive effort for, 15.
 - size of, 8.
 - types of, 9.
- Cascade control, 100.
- Center feeding of sections, 138.
 - of distribution, 199.
- Charging current of line, 247.
- Chimneys, 272.
- Choke coils, 209, 254.
- Classification of conductors, 133.
- Closed cars, 9.
- Coasting curve, 52, 58.
 - effect of changes in, 129.
- Coefficient of adhesion, 24, 50.
- Collecting devices, 140.
- Commutating-pole motors, 27, 55.
- Compensated series motors, 36.
- Compensators, 90, 93.
 - multiple-switch, 94.
- Compounded converters, 172.
- Condensers, 267.
- Conductive compensation, 37.
- Conductor separation, 213.
- Conductors, resistance of, 220.
 - weights of, 202, 220.
- Connecting-rod drive, 41.
- Contact conductors, 134.
- Continuous rating of motors, 119.
- Control, alternating-current, 90.
 - apparatus, weights of, 55.
 - cascade, 100.
 - compensator, 93.
 - direct-current, 74.
 - field excitation, 89.
 - hand, 103.
 - induction motor, 96.
 - regulator, 90.
 - methods of, 74.
 - multiple-unit, 105.
 - rheostatic, 74.
 - series-parallel, 75.

- Controllers, 103.
- Converter, characteristics of, 171.
 - substations, 169.
 - transformer deficiencies, 183.
- Convertible cars, 9.
- Cooling towers, 269.
- Copper loss of motor, 118.
- Corona, 213.
 - loss, 214, 247.
- Corrosion, electrolytic, 157.
- Cost constants, 185.
 - of electrical energy, 299.
 - of hydraulic development, 293.
 - movers, 295.
 - of steam stations, 279.
 - of substation units, 174.
 - of transformers, 208.
- Critical line voltage, 213.
- Cross section of contact conductor, 135.
 - of feeder, 151.
 - of line conductor, 206.
 - of supplementary conductor, 143.
- Current, average, per car, 112.
 - curves, 111.
 - density, economic, 152.
 - distribution on lines, 240.
 - effective, motor, 113.
 - limit relay, 109.
- Curves in roadway, 20.

- Daily load diagrams, 180.
- Dams, 288.
- Data for plotting speed curves, 53.
- Deficiency constants, 184.
- Degree of track curvature, 21.
- Density factor of air, 215.
- Depreciation of generating plants, 297.
- Design of controller units, 79.
- Developments, hydraulic, 288.
 - cost of, 293.
- Direct-current control, 74.
 - motors, 27.
 - transmission, 166.
- Disruptive critical voltage, 219.
- Distance curves, 66.
- Distributing system, 133.
- Distribution of current on lines, 240.
- Diversity factor, 210, 260.

- Double-decked cars, 9.
 - stations, 275.
- Drive, methods of, 41.
- Duration of stops, 56.

- Earnings per car-mile, 5.
- Economic current density, 152.
 - section of contact conductor, 135, 177.
 - spacing of substations, 176.
 - transmission voltage, 205.
- Economizers, 272.
- Effective motor current, 113.
 - per trip, 116.
- Effect of operating conditions on energy consumption, 124.
- Efficiency of hydraulic movers, 285.
 - of substation apparatus, 170.
 - of transformers, 168, 203.
 - of transmission, 246.
- Electrical energy, cost of, 299.
- Electric field intensity near conductors, 214.
- Electrolytic corrosion, 157.
 - surveys, 161.
- E.M.F. equation of single-phase motors, 32, 38.
- Elevation of outer rail, 22.
- End feeding of sections, 137.
- Energy consumption, 111.
 - effect of operation on, 124.
 - for car propulsion, 120.
- Engineer's problem, 1.
- Engines, steam, 265.
- Equations of wave propagation, 235.
- Equivalent grade, 20.
 - hours of operation, 182.
 - line length, 211.
- Expenses per car-mile, 6.

- Feeders, 151.
 - negative, 157.
- Feed-water heaters, 272.
- Field control, 89.
- Fixed charges of power station, 264.
- Floor space in power stations, 274.
 - in substations, 170.
- Forced compensation, 37.
- Frequency, 203.
 - resonant, of line, 204.

- Friction, coefficient of, 24.
- Gas engines, 264.
- Gates for turbines, 282.
- Gear drive, 41.
ratio, choice of, 56.
effect on acceleration rate, 131.
- Generators for power station, 261.
- Governors for hydraulic movers, 284.
- Grades, 20.
- Graphic time-tables, 147.
- Grid resistances, 80.
- Ground wires, 258.
- Hand control, 103.
- Heating of motors, 51, 118.
- Heights of chimneys, 273.
- Horsepower rating of motors, 119.
- Hydraulic construction, 288.
power stations, 281.
- Hyperbolic functions, 224.
- Impedance of rails, 164.
- Impulse wheels, 281.
- Income of electric railways, 5.
- Inductance of lines, 222.
- Induction motor, 40.
control of, 96.
regulators, 90.
- Inductive compensation, 37.
- Ingredients of third rails, 135.
- Installations, substation, cost of, 175.
- Insulators, 207.
- Internal combustion engines, 264.
- Interpole motors, 27, 55.
- Ionization of air, 215.
- Iron loss of motor, 118.
pipes, resistance of, 163.
- Jet condensers, 268.
- Leakage current, 157.
- Leakance, line, 237.
- Length of average passenger ride, 8.
of track for urban road, 2.
- Lightning, 251.
arresters, 209, 254.
protection, 254.
- Limitations of motors, 50.
- Limiting line voltages, 219.
- Line capacity, 230.
inductance, 222.
leakance, 237.
resistance, 220.
- Load curves, 180, 259.
- Location of substations, 175.
of transmission line, 199.
- Locomotives, electric, 40.
- Losses in motors, 118.
in substations, 184.
- Master controllers, 106.
- Mechanical draft apparatus, 273.
- Mixed-flow turbine, 281.
- Motor capacity, 51.
characteristic curves, 44.
control, 74.
effective current, 113.
-generator substations, 170.
heating, 51, 118.
limitations, 50.
output, 49.
saturation curve, 79, 87.
- Motors, alternating-current, 26.
compensated series, 36.
direct-current, 27.
field-control, 89.
induction, 40.
railway, 26.
repulsion, 39.
series, 27, 30.
weights of, 55.
- Moutiers-Lyons transmission, 166.
- Multiple-switch compensator, 94.
-unit control, 105.
- Narragansett type of car, 10.
- Negative conductors, 133.
track feeders, 157.
- Nominal rating of motors, 110.
- Number of cars for urban road, 4.
of units in substations, 180.
- Numerical examples, 18, 59, 67,
87, 113, 127, 186, 205, 211,
218, 244, 250, 287.
- Obsolescence of generating plants, 297.
- Oil switches, cost of, 209.
- One-man cars, 10.
- Open cars, 9.

- Operating characteristics of converters, 171.
 of motor-generators, 172.
 conditions, changes in, 124.
 expenses of power stations, 264, 280, 299.
 of railways, 6.
 Output of power stations, 261.
 Overload capacity of generators, 182, 263.
 coefficient, 180.
 Overrunning third rail, 141.
 Oxide-film arrester, 256.
- Pantograph frames, 141.
 Passenger factor, 3.
 Pay-as-you-enter cars, 10.
 Performance curves of motors, 44.
 Phase converters, 29.
 Phases, number of, 201.
 Pipes, resistances of, 163.
 Plotting speed curves, 56.
 with grades and curves, 67.
 Polarity induction motor control, 97.
 Poles, transmission, 207.
 trolley, 140.
 Population served by railway, 4.
 Portable substations, 193.
 Positive conductors, 133.
 Power factor curves, 122.
 of single-phase motors, 34, 38.
 lost in conductors, 138.
 -station buildings, 274.
 costs, 264, 279.
 location of, 200.
 output, 261.
 Preventive coils, 93.
 Prime movers, types of, 263.
 Problems, 14, 25, 49, 73, 110, 132, 164, 197, 258, 301.
 Propagation of electric waves, 235.
 Protection from lightning, 254.
 Pumps for steam stations, 268.
- Quill drive, 43.
- Rails, 155.
 impedance of, 164.
 Rates of acceleration, 23.
 of braking, 53.
- Reactance set, 172.
 Receipts of electric railway, 4.
 Regeneration of energy with induction motors, 40.
 Regulation of converters, 171.
 of transmission line, 243.
 Regulators, induction, 90.
 Relative operating expenses of generating plants, 299.
 weights of conductors, 202.
 Relay, current-limit, 109.
 Repulsion motors, 39.
 Resistance of conductors, 220.
 offered to car movement, 15.
 of iron pipes, 163.
 of third rails, 136.
 of track rails, 156.
 to alternating currents, 221.
 Resistances, motor starting, 78.
 Resonant currents, 253.
 frequency of line, 204.
 Retardation, 24.
 Reversing motors, 103.
 Rheostatic control, 74.
 Ride, average passenger, 8.
 Rights of way, 200.
 Roadway, characteristics of, 56.
 Rolling friction, 15.
- Saturation curve of motors, 79, 87.
 Schedule speeds, 13, 56.
 Scott transformer connection, 29, 169.
 Seating capacity of cars, 9.
 Seats, arrangement of, 10.
 Sectional contact conductors, 138.
 Selection of gear ratio, 56.
 of generator units, 261.
 Semiconvertible cars, 9.
 Separation of line conductors, 213.
 Series-parallel control, 75.
 -wound motors, 27, 30.
 Service, railway, types of, 1.
 Single-phase railway motors, 30.
 Skin effect, 221.
 resistance of rails, 164.
 Speed curves, 50.
 of car, 51.
 of hydraulic movers, 287.
 of motor, 26, 49.

- Stacks, 272.**
Standard transmission voltages, 212.
Starting resistances, 78.
 energy lost in, 125.
Station load curves, 259.
Steam power stations, 265.
Stops, duration of, 56.
Storage batteries, 188.
Substations, 166.
 arrangement of apparatus in, 189.
 automatic, 188.
 cost of, 175.
 efficiency of apparatus in, 170.
 floor space in, 170.
 location of, 175.
 number of units in, 180.
 portable, 193.
 connections of, 197.
 Superheaters, 266.
Supplementary conductors, 142.
Surface condensers, 268.
Surges from lightning, 253.
Surveys, electrolytic, 161.
Synchronous speed of induction motors, 97.

Table of hyperbolic functions, 228.
Temperature elevation of motors, 119.
Third rails, composition of, 136.
 resistance of, 136.
Three-phase railway motors, 40.
 -point grid resistance, 80.
Thury transmission system, 166.
Time-tables, graphic, 148.
Total drop in conductor, 135.
Towers, transmission, 207.
Track factor, 3.
 feeders, 157.
 length of, for urban road, 2.
 rails, 155.
Traction motors, 26.
Traction effort, 15, 49.
 -speed curve, 60.

Train resistance, 15.
 -sheets, 148.
Trains, 13.
Transformer efficiencies, 168, 203.
Transformers, costs of, 208.
 weights of, 203.
Transmission lines, 199.
Trolley wheels, 140.
 wires, 135.
Turbines, hydraulic, 281.
 steam, 265.
Typical speed curves, 52.

Underrunning third rail, 142.
Units, controller resistance, 79.
 generator, 262.
Urban road, cars for, 1.

Vacuum heaters, 272.
 pumps, 268.
Velocity of car, 51.
 of wave propagation, 243.
Voltage along roadway, 129.
 critical, 213.
 curves, 118.
 distribution on lines, 240.
 gradient, 214.
 of boosters, 154.
 regulation, 243.
 transmission, economic, 205.

Wages of substation attendants, 178.
Water-power development, 288.
 wheels, 284.
Watts lost in conductor, 138.
Wave-length coefficient, 238.
 propagation along wires, 235.
Weights of car equipments, 54.
 of cars, 13.
 of conductors, relative, 202.
 of iron pipe, 163.
 of transformers, 203.
Wheels, trolley, 140.
Wind resistance, 16.

1

2

D. VAN NOSTRAND COMPANY

are prepared to supply, either from
their complete stock or at
short notice,

Any Technical or Scientific Book

In addition to publishing a very large and varied number of SCIENTIFIC AND ENGINEERING BOOKS, D. Van Nostrand Company have on hand the largest assortment in the United States of such books issued by American and foreign publishers.

All inquiries are cheerfully and carefully answered and complete catalogs sent free on request.

25 PARK PLACE - - - NEW YORK

Vertical line of text or markings on the left side of the page.